

ISSN 2313-5891 (Online)
ISSN 2304-974X (Print)

Ukrainian Food Journal

***Volume 4, Issue 4
2015***

Київ

2015

Київ

Ukrainian Food Journal is an international scientific journal that publishes innovative papers of expert in the fields of food science, engineering and technology, chemistry, economics and management.

The advantage of research results publication available to students, graduate students, young scientists.

Ukrainian Food Journal is abstracted and indexed by scientometric databases:

Ukrainian Food Journal – міжнародне наукове періодичне видання для публікації результатів досліджень фахівців у галузі харчової науки, техніки та технології, хімії, економіки і управління.

Перевага в публікації результатів досліджень надається студентам, аспірантам та молодим вченим.

Ukrainian Food Journal індексується наукометричними базами:

Index Copernicus (2012)

EBSCO (2013)

Google Scholar (2013)

UlrichsWeb (2013)

Global Impact Factor (2014)

CABI full text (2014)

Online Library of University of Southern Denmark (2014)

Directory of Research Journals Indexing (DRJI) (2014)

Universal Impact Factor (2014)

Directory of Open Access scholarly Resources (ROAD) (2014)

European Reference Index for the Humanities and the Social Sciences (ERIH PLUS) (2014)

Directory of Open Access Journals (DOAJ) (2015)

InfoBase Index (2015)

Ukrainian Food Journal включено у перелік наукових фахових видань України з технічних наук, в якому можуть публікуватися результати дисертаційних робіт на здобуття наукових ступенів доктора і кандидата наук (Наказ Міністерства освіти і науки України № 1609 від 21.11.2013)

Editorial office address:

National University
of Food Technologies
Volodymyrska str., 68
Ukraine, Kyiv 01601

Адреса редакції:

Національний університет
харчових технологій
вул. Володимирська, 68
Київ 01601

e-mail: ufj_nuft@meta.ua

Scientific Council of the National
University of Food Technologies
recommends the journal for printing.
Minutes № 11, 24.12.2015

Рекомендовано вченою радою
Національного університету
харчових технологій.
Протокол № 11 від 24.12.2015 р.

© NUFT, 2015

© НУХТ, 2015

Ukrainian Food Journal publishes original research articles, short communications, review papers, news and literature reviews.

Topic covered by the journal include:

Food engineering	Food nanotechnologies
Food chemistry	Food processes
Food microbiology	Economics and management
Physical property of food	Automation of food processes
Food quality and safety	Food packaging
Health	

Periodicity of the journal - 4 issues per year.

Studies must be novel, have a clear connection to food science, and be of general interest to the international scientific community.

Ukrainian Food Journal is indexed by scientometric databases:

Index Copernicus (2012)

EBSCO (2013)

Google Scholar (2013)

UlrichsWeb (2013)

Global Impact Factor (2014)

Online Library of University of Southern Denmark (2014)

CABI full text (2014)

Directory of Research Journals Indexing (DRJI) (2014)

Universal Impact Factor (2014)

Directory of Open Access scholarly Resources (ROAD) (2014)

European Reference Index for the Humanities and the Social Sciences (ERIH PLUS) (2014)

Directory of Open Access Journals (DOAJ) (2015)

InfoBase Index (2015)

Reviewing a Manuscript for Publication. All scientific articles submitted for publication in “Ukrainian Food Journal” are double-blind reviewed by at least two academics appointed by the Editors' Board: one from the Editorial Board and one independent scientist.

Copyright. Authors submitting articles for publication warrant that the work is not an infringement of any existing copyright and will indemnify the publisher against any breach of such warranty. For ease of dissemination and to ensure proper policing of use papers and contributions become the legal copyright of the publisher unless otherwise agreed.

Academic ethics policy. The Editorial Board of "Ukrainian Food Journal" follows the rules on academic writing and academic ethics, according to the work by Miguel Roig (2003, 2006) "Avoiding plagiarism, self-plagiarism, and other questionable writing practices. A guide to ethical writing". The Editorial Board suggests to potential contributors of the journal, reviewers and readers to dully follow this guidance in order to avoid misconceptions in academic writing.

For a **full guide for Autor** please visit website at

<http://ufj.ho.ua>

Editorial board

Editor-in-Chief:

Valerii Mank, Ph. D. Hab., Prof., *National University of Food Technologies, Ukraine*

Members of Editorial board:

Aleksandr Mamtsev, Ph. D. Hab., Prof., *Branch of Moscow State University of Technologies and Management, Meleuz, Bashkortostan, Russia.*

Anatolii Saiganov, Ph. D. Hab., Prof., *Institute of System Research in Agroindustrial Complex of NAS of Belarus*

Galyna Simakhina, Ph. D. Hab., Prof., *National University of Food Technologies, Ukraine*

Cristina Popovici, Ph.D., As. Prof., *Technical University of Moldova*

Mark Shamtsian, PhD, As. Prof, *St. Petersburg State Technological Institute, Russia*

Mykola Sychevskiy, Ph. D. Hab., Prof., *Institute of Food Resources of National Academy of Sciences of Ukraine*

Olga Rybak, Ph.D., As. Prof., *Ternopil National Technical University "Ivan Puliui", Ukraine*

Pascal Dupeux, Ph.D., *University Claude Bernard Lion 1, France*

Stefan Stefanov, Ph.D., Prof., *University of Food Technologies, Bulgaria*

Tetiana Mostenska, Ph. D. Hab., Prof., *National University of Food Technologies, Ukraine*

Tetiana Pyrog, Ph. D. Hab., Prof., *National University of Food Technologies, Ukraine*

Tomasz Bernat, Ph. D. Hab., Prof., *Szczecin University, Poland*

Valerii Myronchuk, Ph. D. Hab., Prof., *National University for Food Technologies, Ukraine*

Viktor Stabnikov, Ph.D., As. Prof., *National University for Food Technologies, Ukraine*

Virginija Jureniene, Ph. D., Prof., *Vilnius University, Lithuania*

Vladimir Grudanov, Ph. D. Hab., Prof., *Belarusian State Agrarian Technical University*

Volodymyr Ivanov, Ph. D. Hab., Prof., *Iowa State University, USA*

Yuliia Dziacko, Ph. D. Hab., Prof., *Institute of general and inorganic chemistry «Vernadskii» of National Academy of Sciences of Ukraine*

Yordanka Stefanova, Ph.D, *University of Plovdiv "Paisii Hilendarski", Bulgaria*

Yurii Bilan, Ph.D., As. Prof., *Szczecin University, Poland*

Oleksii Gubenia (*accountable secretary*), Ph.D., As. Prof., *National University of Food Technologies, Ukraine*

Contents

Food safety	577
<i>Natalia Penkina, Larisa Tatar, Ganna Zaychenko, Dmytro Lytkin</i> Research of the toxicological and pharmacological effects of new blends on the body of biological objects.....	577
Food technologies	587
<i>Esther Laduni, Adewumi Toyin Oyeyinka, Samson Adeoye Oyeyinka, Charles Ogugua Aworh</i> Effect of drying method and cereal type on functional and pasting properties of ogi powder.....	587
<i>Olena Hrabovska, Hanna Pastukh, Oksana Demenyuk, Volodymyr Miroshnyk, Tetyana Halatenko, Alina Babii, Alina Dobrydnuk</i> Kinetics of hydrolysis-extraction of pectin substances from the potato raw materials.....	596
<i>Michael Mayokun Odewole, Zainab Oyinlola Ayodimeji, Kehinde Peter Alabi</i> Post-storage qualities of pre-treated dried red bell pepper.....	605
Biotechnology, microbiology	617
<i>Musliu Olushola Sunmonu, Michael Mayokun Odewole, Aliu Olamide Oyedun, Hafsat Funmilayo Bankolen</i> Identification and characterization of bacterial and fungal isolates in raw milk samples from different breeds.....	617
<i>Natalia Husyatynska, Svitlana Teterina, Tetiana Nechipor, Irina Kasian</i> Disinfectants efficiency on microorganisms - active gray rot causative agents within the process of sugar beet storage.....	626
Processes and equipment of food productions	638
<i>Ivanna Kyrychuk, Valerii Myronchuk, Yurii Zmiievskii, Serhii Holiachuk</i> Two-stage whey treatment by nanofiltration and reverse osmosis.....	638

<i>Taras Pogoriliyy</i> Temperatures distribution in the «larger sugar crystal–larger crystal sucrose solution–less crystal sugar sucrose solution–smaller sugar crystal–massecuite» cells system depending on the boiling sugar massecuite time.....	648
<i>Anastasiia Klieshchova, Arcadiy Pietuhov</i> Influence of cobalt stearate on destabilization of high-pressure polyethylene.....	662
Economics and management	674
<i>Tomáš Sadílek</i> Buying dietary supplements and over the counter drugs in the Czech Republic.....	674
<i>Liudmyla Shevchenko</i> Innovative trends for the alcohol enterprises of Ukraine.....	684
Abstracts	694
Instructions for authors	713

Research of the toxicological and pharmacological effects of new blends on the body of biological objects

Natalia Penkina¹, Larisa Tatar¹,
Ganna Zaychenko², Dmytro Lytkin²

1 – Kharkiv State University of Food Technology and Trade, Kharkiv, Ukraine

2 – National University of Pharmacy, Kharkiv, Ukraine

Keywords:

Drink
Antioxidant
Toxicness
Alcohol
Coupage

Article history:

Received 12.10.2015
Received in revised form
18.11.2015
Accepted 24.12.2015

Corresponding author:

Larisa Tatar
E-mail:
tornado.1972@mail.ru

Abstract

Introduction. A research aim is a toxicological study to the coupage from a digister that is used for making of low-alcoholic drinks.

Materials and methods. The drink made the method of natural fermentation contains to the 4,0% alcohol and mixture of extract substances of different plants with high antioxidant ability. Studied subsharp toxicness to the coupage and his influence on the prooxidant-antioxidant state of liver of white mice comparatively with solution of alcohol of 4,0% and beer of 4,0%.

Results and discussion. After intragastric introduction to the coupage in a maximal for these animals dose 36,1 g/kg during 14 days of signs of intoxication for animals were not observed. Middle mass of animals (24,33 g) kept indoors outside a physiology norm and did not differ ($p > 0,05$) from the indexes of middle mass of animals of group of intact control (24,33 g).

Mass coefficient of liver (0,1g/10,0g) for the animals of intact control (38,567) and those a coupage (39,467) was entered that, considerably differed from the liver of animals beer (42,867) and solution of ethyl spirit (45,633) was entered that, is beginning of development of scraw displays, in particular hypertrophies of organ. A coupage diminishes in general lines toxic influence to the alcohol on the organism of animals that normalizes the coefficient of mass of liver.

Biochemical researches of homogenate fabrics are livers of animals a coupage shown that on content in the liver of diene conjugates (3,633 mkmol/g), TBA-reagents (2,500 mkmol/g), renewed glutathione (2,420 mkmol/g) and catalase (0,163 mkmol/min-g) did not statistically different from the indexes of animals of intact control and been within the limits of physiology norm. In the group of animals beer was entered that, content of renewed glutathione (2,267 mkmol/g) went down and activity of catalase (0,153 mkmol/min-g) diminished. In the group of animals solution of alcohol was entered that, reliable change ($p < 0,05$): content of TBA-reagents (3,033 mkmol/g) grew, content of renewed glutathione (2,333 mmol/g) went down and activity of catalase (0,157 mkmol/min-g) was repressed.

Conclusions. Drinks on the basis of investigated to the coupage due to the presence of the alcoprotector operating on a liver, can be an alternative to the modern beerhouses and low-alcoholic drinks that is produced with the use of alcohol ethyl.

Introduction

Today a consumption of alcohol is a meaningful social, cultural, psychological and medical factor. According to last given of World Organization of health a leader in the consumption of alcohol is Europe and poisoning an alcohol is reason of death 3,3 million people on a year in the whole world. Middle part of consumption of alcohol in Ukraine presents a 13,9 litre, from what 40% is on beer, beerhouses and low-alcoholic drinks [1].

First of all potential harm from the consumption of beer and some low-alcoholic drinks of brands with high maintenance of alcohol can be caused by that the process of their preparation envisages addition of clean food ethyl spirit without the admixtures of methanol and aldehydes [2]. This alcohol must be got by fermentation of products with high maintenance of glucose (from a beet, potato, feed treacle and other). However cheaper raw material for the receipt of alcohol ethyl are arboreal sawdusts (receipt of alcohol by the method of hydrolysis of cellulose). The alcohol got thus has high maintenance of admixtures: fusel oil, alcohols of C₃-C₆, methanol, that are very toxic for a human organism [3].

The above-mentioned grounds advantages of the drinks got by yeast fermentation without addition the alcohol (beer, wine, cider and other).

It costs to mark that an alcohol in any shape or form finds out the dose-dependent toxic operating on the organism of man. In case of overconsumption of alcohol there is progress of cardiovascular, chronic diseases of organs of digestion, there is an alcoholic psychosis, miorenalny syndrome, cerebral and lungs edema and others like that. Alcohol is particularly dangerous for children, teenagers, pregnant women, seniors [4].

High power value of alcohol together with insufficient content of microelements and vitamins negatively influence on the state of health of man and are reason of origin of serious alimentary problems [5].

Adding to the alcoholic beverages of extracts of plants, that have in the composition a complex of antioxidants, vitamins and microelements, can decrease the toxic action of alcoholic products and give the last certain useful properties [6].

The aim of the study. A toxicological and pharmacological study became the aim of this research to the coupage from a digister, that offers for making of low-alcoholic drinks, comparatively with solution of alcohol of 4,0% and beer of 4,0% (intra-gastric introduction to the white mice during 14 days one one time per days). Pharmacological research of drinks included the study of influence on prooxidant-antioxidant status of liver of animals.

Study is undertaken on the base of the Central research laboratory of the National pharmaceutical university, that is certificated State Expert Centre of Ministry of Health of Ukraine, as a base of researches from experimental pharmacology. Before the beginning of experiment animals passed acclimatization in a room for testing during seven days; mice passed a quarantine and corresponding acclimatization according to operating norms.

Materials and methods

Composition and technology of preparation to the coupage from a digister for low-alcoholic drinks (BPMD) were worked out in the Kharkiv state university of feed and trade on the department of merchandizing on custom business. The marked drink is made the method of fermentation, he contains to the 4,0% alcohol and mixture of extract substances of different plants with high maintenance of antioxidants, mass %:

chokeberry 35,0–37,0;
dry hop cones 2,0–4,0;
pine needles 1,0–2,0;
ginger 0,3–0,5;
stevioside 0,3–0,5;
wine yeast 0,2–0,4;

water and whey (from the cheese dairy) – rest.

Chokeberry has in the composition: vitamins and provitamins (A, C, E, K, P, vitamins of group B), microelements (phosphorus, magnesium, manganese, iron), organic acids, tanning and pectin substances. These bioactive substances (BAS) positively influence to work of thyroid, cardiovascular and nervous system, show the bracing operating on the organism of man, increasing resistance to the unfavorable factors of environment [7].

The cones of hop contain dry flavonoids, essential oil and organic acids. Marked higher BAS able to find out седативну and antimicrobial action, to improve an appetite and general of organism of man [8-10].

Among BAS, that enter in the complement of pine-needle of pine-tree, also distinguished vitamins (A, E, C), microelements (zinc, cobalt, copper, calcium), resins, fat and organic acids, essential oil, glycosides and phenic connections that are antioxidant characteristics. The BAS of pine-needle of pine-tree bracing, antimicrobial and antiinflammatory properties find out [11].

A ginger root is antiseptic and restorative characteristics, high antioxidant potential due to high maintenance of essential oil able to inactivate free radicals of oxygen and improve circulation of blood of brain [12].

Stevioside (glycoside that is contained in the plants of sort of Stevia), that is included in composition to the coupage as a proof-reader of taste, capable to normalize a piosis, diminish the symptoms of heartburn, level of urinary acid and glucose in blood [13].

A lactoserum is a source squirrel, mikro- and macronutrients, a most value from that has a calcium. Laktoalbuminy and lactoglobulins (in composition serum proteins) contain most irreplaceable amino acids, also these albuminous factions are antioxidant characteristics [14].

A study of toxicness is the obligatory stage of research of new medical and food products, that allows to estimate the unconcern of substances for the health of man. In this experiment studied subsharp toxicness that envisages the receipt of data in relation to toxic property of substance as a result of introduction of her during a limit time. BPMD entered to the animals during 14 days that answers two months of application for people.

Subsharp toxicness of BPMD of investigated comparatively with beer («Lviv light», the company «Carlsberg Ukraine», by volume part of alcohol of 4,0%, party № 16.06.15.08.30) and solution of alcohol of ethyl 4,0%. Conducted experiment on mise of both sexes at intragastric introduction that is envisaged for application of drink in practice and is expedient, taking into account possibility of casual situations that cause accidents, suicidal and criminal poisoning or cases of abuse of alcoholic beverages [15].

Study was undertaken on 48 white nonlinear mice – males and females – with body weight 20,0–25,0 g. Before research animals were up-diffused after groups, for 6 animals in each.

Four hours prior to introduction of the investigated substances of animals did not feed. Intragastric introduction was carried out in the morning on an empty stomach. The investigated substances entered slowly by means of special metallic зонда, whereupon animals were held two hours without a meal, but with free access to water.

During the choice of doses for the study of subsharp toxicness at the terms of intragastric introduction introduction of maximally possible volume became a limiting factor for this type of introduction. In accordance with methodical recommendations for mice he presented 0,8 ml on an animal mass 25,0 g, that 32,0 ml/kg (Stefanov O.V., 2001) equal. The also entered amount of substance was enumerated on content of alcohol ethyl, an amount of that for non-permanent introduction 7,5 time had less than, than middle lethal dose. According to literary given, for the alcohol of the ethyl rectified high degree of cleaning a middle lethal dose presents 9,5 ml/kg (7,71 g/kg) [16]. The corresponding volume of the cleared water (table 1) was entered intact animals.

The term of watching animals for the study of subsharp toxicness according to methodical recommendations presented two weeks. Registered the displays of violations of the physiology state of animals, survivability, dynamics of body weight.

After completion a term the supervisions of animals killed by a counteretch, conducted a section and macroscopic inspection of internal organs (heart, liver, brain, kidneys, lungs, spleen, thymus, adrenals, gonads), mass coefficients (MC) expected them.

Table 1

Design of research of subsharp toxicness for BPMD, beer and solution of alcohol of 4,0%

Group	The dosage form substances ml/g (g/kg)	The dose for the active substance (calculated on the ethyl alcohol 96%) ml/kg (g/kg) at a temperature of 20°C	Number of animals in the group	
			males	females
Intragastric route of administration				
Intact control (purified water)	32,0 (32,0)	0 (0)	6	6
KPCCH	32,0 (36,1)	1,28 (1,02)	6	6
Beer	32,0 (34,4)	1,28 (1,02)	6	6
A solution of ethyl	32,0 (31,8)	1,28 (1,02)	6	6

The study of subsharp toxicness included for itself the biochemical analysis of indexes functioning of separate *таргетних* organs, to that the toxic action of substance is sent. As an alcohol the ethyl in the first turn strikes liver, violates antioxidant balance of hepatocytes and accelerates the processes of oxidation of peroxide of lipids for them, then in this research measured prooxidative and antioxidant markers at homogenate fabrics of liver of animals.

For the evaluation of the state of the antioxidant system of animals in homogenate livers determined: content of products of oxidation of peroxide of lipids, id est diene conjugates (DC) and products that react with 2-thiobarbituric acid (TBA-reactants); markers of activity of the antioxidant system, lutation (VH) is namely renewed and activity of catalase.

The markers of prooxidants balance of cages testify to activity of free-radical processes, antioxidants markers – about activity of enzymatic chain of antiradical defence of cages. The classic markers of prooxidants-antioxidants equilibrium are DC, TBA-reactants VH and catalase, here high value of VH and catalase and subzero value of DC,

TBA-reactants testify to normal status of cage, in another case - about activating of oxidation of peroxide of lipids and membrane destruction [17].

The content of diene conjugates in the liver tissue homogenate was determined by the formula

$$C(\text{mkmol/g}) = 227,27 \cdot E_{\text{sample}}, \quad (1)$$

where C – the contents of control;

E_{sample} – absorbance sample studied.

The content of TBA-active products in homogenate of liver tissue studied animals determined by the formula

$$C(\text{mkmol/g}) = \frac{E_{\text{sample}}}{1,56 \cdot 10^5} \cdot 2 \cdot 10^6, \quad (2)$$

where C – the content of TBA-active products;

E_{sample} – absorbance sample studied.

Calculation of reduced glutathione in the liver tissue homogenate was performed by the formula

$$C(\text{mkmol/g}) = E_{\text{sample}} \cdot 1094 \text{Mg}\% \quad (3)$$

where C – glutathione content;

E_{sample} – absorbance sample studied.

The activity of catalase in liver tissue homogenate calculated by the formula

$$E_{\text{cat}}(\text{mM/l} \cdot \text{min}) = \frac{(A_{\text{kontr}} - A_{\text{dosl}})}{K \cdot t} \cdot V \cdot 10^6, \quad (4)$$

where E – catalase activity;

A_{kontr} and A_{dosl} – optical density (extinction) and idle studied samples;

V – volume samples (3,02 ml);

t – incubation time (10 min);

K – millimolar extinction ratio of hydrogen peroxide, $22,2 \cdot 10^3 \text{ mM}^{-1} \text{ cm}^{-1}$.

The obtained experimental data statistically processed the method of variation statistics. Experimental data were worked out by the methods of variation statistics with the use of standard package of softwares «Statistica 6.0» by means of t-criterion of Student for independent selections, U-criterion of Mann-Whitney and transformation of Fisher. Reliable a difference was considered at the level of meaningfulness of $p < 0,05$ (calculated mean arithmetic and him standard error).

Results and discussions

After intragastric introduction of BPMD to the maximal for the marked animals dose – 36,1 g/kg during 14 days of signs of intoxication for animals were not observed: animals were trim, active, had a satisfactory appetite, reacted on voice and light irritants, processes

of urine and defecation were in a norm, violation of breathing and cramps was not. Reflex excitability all animals had stored. During watching animals during two weeks not a single animal perished from this experimental group. Comparison of behavior of animals, consumption of water and meal of experience and intact animals showed absence of no differences.

For animals that during 14 days gave beer of 4,0% in a maximally possible dose, also there were not signs of general intoxication, however agile activity was some less than, than for animals BPMD was entered that, and excretions to urine and defecation took place considerably more often. For 14 days not a single animal perished, but on a 13th day some females had cramps and change of behavior. For some animals the consumption of meal diminished and the consumption of water increased, the excited was marked, increase reaction on voice and auditory irritants.

In the group of animals, where solution of alcohol of ethyl 4,0% was entered mise in a maximally possible volume, there was the registered death of one animal (females) on the 10th day of introduction of substance. Beginning from 8 days of introduction of alcohol for some animals the changes of tint of wool (gray), oppression of motive activity (the states of oppression alternated with the states of an increase excitation) were marked, something excessive selection to urine, increase of consumption of water. Beginning from 10 twenty-four hours some animals had an inadequate reaction on introduction of drink through a probe, to the rumor and light irritants, violations of rhythms of dream and cheerfulness.

Changes in the index of body of animals weight registered on 4, 7 and 14th day introduction of drinks, that answered standard methodology. The masses of body of males and females changed proportionally, but did not differ after a dynamics, that is why it was expedient to compare the general middle masses of animals after groups.

In a group, where to the animals intragastric entered beer, on the 14th day of experience the increase of body weight was noticed, for certain higher than value in the group of intact control. Middle mass of animals solution of alcohol of 4% was entered that opposite, was for certain less than, than analogical index is in the group of intact control. Middle mass of animals BPMD was entered that during all supervision kept indoors outside a physiology norm and did not differ ($p > 0,05$) from the indexes of middle mass of animals of intact control (table 2).

Autopsy and microscopic examination of internal organs of animals spent 14 days after the experiment beginning. The color, texture, finding organs of both sexes of mice control and study groups did not go beyond the physiological norm and did not differ among themselves. Liver of animals injected alcohol and beer were larger in intact mice and liver of animals which was administrated BPMD (Fig. 1).

Table 2
Dynamics of body weight of mice after administration BPMD compared with beer 4,0% solution of ethyl alcohol and 4,0% (g, M ± m)

Day experiment	The tested object			
	Intact control (n = 6)	BPMD (n = 6)	Beer (n = 6)	A solution of ethyl 4,0% (n = 6)
The initial values	19,83±0,87	20,33±0,84	20,17±1,01	20,2±0,66
4th day	21,00±0,97	21,17±0,60	21,83±0,87	21,4±0,51
7th day	22,67±0,67	22,67±0,42	23,67±0,56	22,2±0,66
14th day	24,33±0,67	24,33±0,33	26,00±0,26*	22,4±0,40*

* The change is likely on the values of intact control animals ($p < 0,05$).

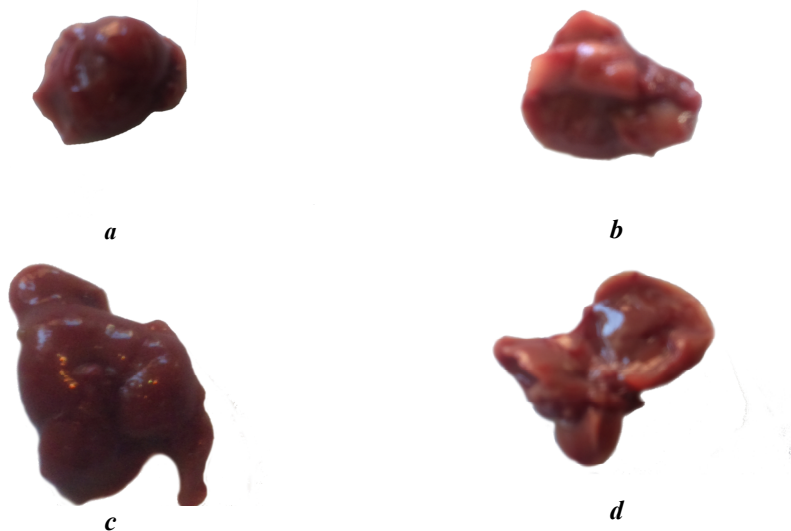

Fig. 1. Appearance of livers of animals on day 14 of the experiment:

a – intact mouse liver;

b – mouse liver which was administered BPMD;

c – mouse liver which was administered beer of 4,0%;

d – mouse liver which was administered the solution of alcohol of ethyl 4,0%

After the calculation of MC of internal organs set, that this index does not differ for animals of both sexes intact control and groups of animals, BPMD (table 4, 5) was entered that. In the group of animals beer (for males and females) was entered that the masses of liver and kidneys increased for certain. Besides MC of gonads for males was for certain less than, than analogical index is in the group of intact control. For animals of both sexes, what 14 during days intragastric entered solution of alcohol of ethyl 4,0%, for certain MC of liver increased comparatively with a physiology norm. Also for males of this group MC spleens was anymore ($p < 0,05$) after MC of this organ for intact animals (table 3, 4).

The brought results over of researches from the study of subsharp toxicness to the coupage from a digister for low-alcoholic drinks showed that due to ingredients that is included in his composition, drink diminishes negative generaltoxic influence to the alcohol on the organism of animals, that normalizes the coefficient of mass of liver first of all. Biometrical index of relative mass of liver of animals, that used beer and solution of alcohol, more than for animals that used the investigated drink, is testifies to beginning of development of scray displays, in particular hypertrophies of organ, although maintenance of alcohol in all investigated drinks was identical.

The results of biochemical researches of homogenate fabrics of liver showed that content of DC, TBA-reagents, VH and catalase in the liver of animals BPMD was entered that, for certain did not differ from the indexes of animals of intact control and was within the limits of physiology norm.

For animals that consumed beer, the level of antioxidant markers (VH, catalase) diminished for certain, comparatively with the indexes of group of intact animals. Introduction solution of alcohol also negatively influenced on proantioxidant balance

tissues of liver of animals. Comparatively with the indexes of intact animals, maintenance of TBA-reagents grew for certain, content of VH went down and activity of catalase (table 5) was repressed.

Table 3
Odds mass of internal organs of male white mice after 14 days intragastric administration beverages studied, M ± m

Mass ratios of 0,1g/10,0g	Experimental group			
	Intact control (n = 6)	BPMD (n = 6)	Beer (n = 6)	A solution of ethyl 4,0% (n = 6)
Liver	38,567±0,173	39,467±0,931	42,867±1,252*	45,633±0,626*
Heart	3,333±0,021	3,333±0,021	3,400±0,110	3,333±0,165
Brain	16,567±0,148	16,567±0,152	16,500±0,073	16,500±0,159
Kidneys	9,667±0,042	9,633±0,165	10,233±0,056*	9,633±0,165
Adrenals	0,183±0,002	0,183±0,013	0,190±0,000	0,190±0,000
Spleen	3,813± 0,008	3,700±0,110	3,813±0,008	4,200±0,110*
Lights	6,633± 0,056	6,667±0,259	6,733±0,021	6,767±0,201
Thumus	0,933± 0,003	0,933±0,003	0,957±0,004	0,933±0,016
Testes	4,100 ± 0,037	4,033±0,076	3,767±0,021*	4,133±0,128

* The change is likely on the values of intact control animals (p < 0,05).

Table 4
Odds mass internal male white mice after 14th day intragastric administration beverages studied, M ± m

Mass ratios of 0,1g/10,0g	Experimental group			
	Intact control (n = 6)	BPMD (n = 6)	Beer (n = 6)	A solution of ethyl 4,0% (n = 6)
Liver	37,467±0,201	37,867± 0,152	39,967±0,595*	40,933±0,138*
Heart	3,500±0,146	3,733±0,112	3,600±0,073	3,800±0,073
Brain	16,100±0,123	16,133±0,220	16,167±0,259	16,233±0,148
Kidneys	9,533±0,076	9,367±0,092	10,267±0,117*	9,667±0,056
Adrenals	0,193±0,004	0,183±0,002	0,183±0,006	0,197±0,002
Spleen	3,767±0,092	3,800±0,110	3,800±0,037	3,867±0,056
Lights	6,200±0,110	6,067±0,076	6,167±0,128	6,200±0,037
Thumus	0,960±0,011	0,950±0,022	0,980±0,038	0,967±0,012
Ovaries	0,263±0,006	0,273±0,011	0,277±0,012	0,263±0,002

* The change is likely on the values of intact control animals (p < 0,05).

Table 5
The content of the antioxidant-markers in mice liver homogenate after 14th days intragastric administration beverages studied, n = 6

Indicator	Intact control	BPMD	Beer	A solution of ethyl 4,0%
Diene conjugates (mkmol/g)	3,700±0,132	3,633±0,056	3,833±0,092	4,033±0,105
TBA-reagents (mkmol/g)	2,733±0,092	2,500±0,058	2,800±0,126	3,033±0,084*
Glutathione (mkmol/g)	2,527±0,064	2,420±0,025	2,267±0,076*	2,333±0,021*
The activity of catalase (mkmol/g·min)	0,203±0,015	0,163±0,013	0,153±0,012*	0,157±0,008*

* The change is likely on the values of intact control animals ($p < 0,05$).

That BPMD in case of intragastric introduction during 14th days did not change proantioxidant balance of liver of animals it is in the first turn related to his composition. Vegetable and serum antioxidants that level harmful influence of alcohol on a liver enter in the complement of drink, promote activity of enzymatic chain of antiradical defence and activating of processes of окиснення of peroxide of lipids in hepatocytes, that is caused by the protracted use of alcohol, prevent.

Conclusions

The investigated product is a coupage for low-alcoholic drinks - did not have a toxic action during inwardly gastric introduction to the biological objects during 14 days in a maximally possible volume. Drink did not influence on macroscopic descriptions of internal organs of animals and their coefficients of mass, comparatively with beer and solution of alcohol of ethyl 4,0%.

From data of biochemical researches of homohenate liver of the mise shown out of experiment after research of subsharp toxicness, a coupage from a digister for low-alcoholic drinks did not change prooxidant-antioxidant balance of fabrics of liver and kept it within the limits of physiology norm. Beer and solution of alcohol of ethyl 4,0% changed this balance in direction of activating of processes of peroxidation.

Low-alcoholic drinks on the basis of investigated to the coupage due to the presence of the алкопротекторної operating on a liver can be an alternative to the modern beerhouses and low-alcoholic drinks that have an ethyl spirit in the composition.

Taking into account all brought indexes over, the drinks created on the basis of worked out to the coupage will be able to lay down a competition to modern low-alcoholic drinks and extend their assortment.

References

1. Global status report on alcohol and health (2014), *WHO Library Cataloguing-in-Publication Data*, Geneva.
2. C.Lucy, W.Jane, S.Claire (2008), Soft drink and «desire to drink» in preschoolers, *International Journal of Behavioral Nutrition and Physical Activity*, 5(1), pp. 60.
3. Miskevich D., Borodinskij A., Petushok N., Konovalenko O., Lelevich V. (2006), Preryvistaja alkogolizacija i pechen': svobodnoradikal'nyj gomeostaz, oksid azota, adaptacionnye mehanizmy, *Biomedicinskaja himija*, 5, pp. 489-495.
4. Watson R. (2014), *In soft drink marketing a funny thing happened on the way to market*, Authorhouse, Salt Lake City and Los Angeles.
5. Deitrich R., Zimatkin S., Pranko S. (2006), Oxidation of Ethanol in the Brain and Its Consequences, *Alcohol Research and Health*, 29(4), pp. 66-73.
6. Gorelikova G., Vasil'eva S., Adaeva A. (2009), Biotehnologicheskie aspekty poluchenija plodovyh vin iz mestnogo syr'ja, *Tehnika i tehnologija pishhevyh proizvodstv*, 3, pp. 19-22.
7. Najda A., Kabuda H. (2013), Content of phenolic compounds and antioxidant properties of fruits of selected orchard shrub species, *Modern Phytomorphology*, 3, pp. 105-109.
8. Ashurst P.P. (2008), *Chemistry and Technology of soft drink and fruit juice*, Wiley & Sons Ltd, Hardcover.
9. Holubkova A., Mosovska S., Sturdik E., Bologhova B. (2013), Hop pellets as an interesting source of antioxidant active compounds, *Scientific journal for food industry*, 7(1), pp. 53-57.
10. Shiva Shanker A., Kodaparthi A., Kumar Pindi P. (2012), Microbial diversity in soft drinks, *Journal of Pharmaceutical and Scientific Innovation*, 54(0), pp. 23-26.
11. Cheng M., Chang W., Chen C., Li W. (2015), Antioxidant properties of essential oil extracted from *Pinus morrisonicola* hay needles by supercritical fluid and identification of possible active compounds by GC/MS, *Molecules*, 20(10), pp. 19051-19065.
12. Eleaxu K.C., Eleaxu C.O. (2012), Physico-chemical Properties and Potential of 6 new varieties of ginger, *American journal of food technology*, 7(4), pp. 214-221.
13. Ashurst P., Hargitt R. (2009), *Soft drinks and fruit juice – problems solved*, Woodhead Publishing, Boston.
14. Suskovic J., Kirin S., Frece J. (2009), Production of fermented probiotic beverages from milk permeate enriched with whey retentate and identification of present lactic acid bacteria, *Mijekarstvo*, 59(1), pp. 11-19.
15. Sigrid G., Susan M. (2013), Beverages consumption habits among British adults: association with total water intake and energy intake, *Nutrition Journal*, 12(1), pp. 9-12.
16. Babak O. (2006), Alkogol'naja bolezn' pecheni. Nauchnye dostizhenija i klinicheskie perspektivy, *Suchasna gastroentirologija*, 6, pp. 4-9.
17. Krasnovskij A. (2004), Fotodinamicheskoe dejstvie i singletnyj kislorod, *Biofizika*, 2, pp. 305-321.

Effect of drying method and cereal type on functional and pasting properties of ogi powder

Esther Laduni¹, Adewumi Toyin Oyeyinka²,
Samson Adeoye Oyeyinka³, Charles Ogugua Aworh¹

1 - Department of Food Technology, University of Ibadan, Ibadan, Nigeria

2 - Department of Food, Agric and Bio-Engineering, Kwara State University, Malete, Nigeria

3 - Department of Home Economics and Food Science, University of Ilorin, Ilorin, Nigeria

Abstract

Keywords:

Functionality
Ogi
Maize
Millet
Sorghum
Foam mat
Drying

Article history:

Received 22.10.2015
Received in revised
form 12.12.2015
Accepted 24.12.2015

Corresponding author:

Samson Adeoye
Oyeyinka
E-mail:
sartf2001@yahoo.com

Introduction. Ogi also known as gruel is a fermented food prepared from cereals. The purpose of this research is to investigate the effect of drying methods and cereal type on functional properties of ogi powder.

Materials and methods. Maize, millet and sorghum (red variety) were obtained from local market in Ibadan, Nigeria. Ogi was prepared by traditional method. The slurry obtained was dried by cabinet and foam mat drying methods. The pasting and other functional properties of the dried ogi were assessed using standard methods.

Results and discussion. Drying method did not influence the pH, and gelling ability of ogi prepared from maize, millet and sorghum grains. However both drying method and cereal type influenced the pasting and other functional properties of the dried ogi powder. Foam mat dried ogi samples generally showed significantly ($p < 0.05$) lower peak viscosities compared to cabinet dried samples. With increasing concentration of foaming agent from 5 to 15%, the peak viscosities of the dried ogi showed a progressively reduced. However, cabinet dried ogi cooked faster (78-79°C) than foam mat dried samples (80-95°C) as indicated by their pasting temperatures. Foam mat dried ogi samples generally had higher water absorption capacities than cabinet dried ogi.

Conclusions. Foam mat dried ogi powder show better water absorption capacity dispersibility, foamability, and viscosity compared to cabinet dried samples. The selection of a particular drying method for ogi will depend on the desired application.

Introduction

Ogi also known as gruel is a fermented food produced by wet milling of maize, sorghum or millet. Traditionally, it is prepared by natural fermentation. Cereal grains are soaked in water for 2-5 days at room temperature (20-25°C). Ogi has variable nutritional and sensory qualities depending on the area of production [1]. According to Adeyemi and Beckley [2] the period of fermentation determines the degree of sourness and to a large extent the nutritional value of ogi. Ogi is a popular starchy porridge in the west coast of Africa [3]. The use of sorghum, millet and maize in the production of ogi has can create variety especially among adults. Ogi has a limited shelf life, often less than ten days except when refrigerated [4]. The high moisture content of ogi slurry predisposes it to spoilage. However the reduction in moisture content through drying can enhance its shelf life, provide convenience and allow for easy reconstitution of the ogi powder [5]. Air drying is the common drying method employed for extending product shelf life [6]. Drying can seriously affect the nutritional value of foods. For instance, the quality of dried products has been reported to be often lower compared to the original material [7]. However, the development of foam mat drying has been found to shorten drying time which enhances product quality [8]. The combination of foaming and hot air drying may be a feasible option to produce ogi with better colour, flavour and overall quality because of minimal heat-damage. The use of foam mat drying for the production of ogi powder from maize millet and sorghum has been reported [5]. The authors reported lower moisture content for foam mat dried ogi powder compared to cabinet dried ogi. The protein content of the ogi powder was reported to increase with increase in foaming agent concentration. Further, the sensory attributes of foam mat dried ogi was reported to compare favourably with freshly prepared ogi [5]. However, the information on the functional and pasting properties of ogi powder prepared by foam mat drying has not been reported. Therefore, the objective of this work was to determine the effect of drying methods on functional and pasting properties of ogi prepared from maize, millet and sorghum.

Materials and methods

Materials

Maize, millet and sorghum (red variety) were obtained from local market in Ibadan, Nigeria. The grains were of high quality with no evidence of weevil growth. Grains were transferred immediately to the Food Technology laboratory, Department of Food Technology, University of Ibadan, Nigeria. The grains were cleaned and used immediately for the production of ogi.

Methods

Preparation of cabinet dried ogi. Ogi was prepared using the method described by [5]. Briefly, maize, sorghum and millet were sorted, steeped in tap water for 72 h. After decanting the steeping water; they were milled in an attrition mill and sieved through muslin cloth. The slurry was left to ferment for 12 h before decanting the water. The Ogi paste was dried in a cabinet dryer at 60°C for 24 h, milled and packaged.

Foam-mat drying of ogi. Glyceryl monostearate (GMS) suspension (20%) was prepared by dissolving 20 g of GMS in 80 mL of hot water at 100°C. The mixture of GMS

and hot water were transferred into a blender and blended at maximum speed until a smooth suspension was formed. The required quantity of foaming agent (GMS) suspension was added to ogi paste at different concentration of 5%, 10% and 15% (w/w). The mixture was whipped in a Kenwood Chef mixer at maximum speed until homogenous foam was obtained. The foams were extruded on a perforated wire meshes and dried at 60°C in a Gallenkamp oven, milled and packaged [5].

Bulk density. Loose and packed bulk density were determined by method described by Mpotokwane et al. [9] with few modification. Ogi powder was gently transferred into 10 mL graduated cylinders that were previously weighed. The bottom of the cylinder was gently tapped on a laboratory bench several times until no further diminution of the sample level was observed after it was filled up to the 10 mL mark. Bulk density was calculated as the ratio of the bulk weight and the volume of the container.

Water absorption capacity. Water absorption capacity was determined as described by Oyeyinka et al. [10]. Briefly, 10 mL of water was added to 1g of powder samples and the suspension was vortexed for 5 min. The suspension was allowed to stand for 30 min and centrifuged at 3,000 rpm for 30 min. the supernatant obtained was discarded. The residue was air dried and weighed.

Least gelation concentration. Sample suspensions of 2%, 4%, 6%, 8%, 12%, 14%, 16%, 18% and 20% (m/v) were prepared in 5 mL distilled water in test tubes. The tubes containing the suspensions were heated for 1 h in a gentle boiling water bath, after which the tubes were cooled rapidly in water and later cooled at 4°C for 2 h. Each tube was then inverted one after the other. The LGC was taken as the concentration at which the sample from the inverted test tube did not fall or slip [11].

Dispersibility, pH and TTA. Dispersibility of ogi powder was determined as described by [12], while pH and TTA was determined using standard method [13].

Foam Capacity. Sample (2 g) was weighed and dispersed in 100 mL of distilled water, whipped at 1600 rpm for 5 min. The foam formed was transferred into 250 mL measuring cylinder and the volume was recorded after 30. Foam capacity was calculated as the ratio of the ratio of the change in foam volume to the initial volume of the foam.

Pasting. The pasting properties of the ogi powder were examined using a Rapid Visco Analyzer (Newport Scientific Australia) according to standard method provided by the instrument manufacturer. Sample was weighed (2.8 g) into the test canister containing 25 ml of distilled water. The mixture was agitated by mixing manually before inserting the canister into the instruments. Starch was stirred at 960 rpm for 10 s before the shear input was decreased and held constant at 160 rpm during the subsequent heating and cooling cycles. The suspension was heated from 50 to 95 °C in 3 min and 42 s, held at 95 °C for 3 min and 10 s before cooling to 50 °C over 3 min and 48 s.

Statistical analysis. All experiments were conducted in duplicate. Data were analysed using analysis of variance (ANOVA) and means were compared using Fischer's Least Significant Difference Test ($p < 0.05$).

Results and discussion

Pasting properties. Grain type and drying method significantly ($p<0.05$) influenced the pasting properties of ogi powder (Table 1&2). Cabinet dried millet-ogi showed the highest peak viscosity (3589 RVU) while maize-ogi had the lowest value of 3426 RVU (Table 1). Peak viscosity of food material also referred to as swelling peak is influenced by many factors including amylose and lipid content. Starch represents the bulk of the carbohydrate in most cereals. Thus, it should significantly contribute to the viscosity of starchy grains such as maize, millet and sorghum. Starches with high amylose contents is reported to show restricted swelling [14]. According to Tester and Morrison [15], lipids may restrict starch swelling during pasting and gelatinization. Thus, the lower peak viscosity of cabinet dried maize ogi may be attributed to variation in amylose content of the respective grains. The higher lipid content in maize compared to that of sorghum and millet grains may also contribute to the observed differences in peak viscosity. Further, the variation in peak viscosity among the ogi types may also be attributed to differences in starch content. Previous studies associated high peak viscosity of ogi with high starch content [16, 17].

Foam mat dried ogi samples generally showed significantly ($p<0.05$) lower peak viscosities compared to cabinet dried samples (Table 2). With increasing concentration of foaming agent from 5 to 15%, the peak viscosities of foam mat dried ogi progressively reduced. This trend was observed for all the cereal used in this study. In comparison to cabinet dried samples, foam mat dried ogi with 15% foaming agent concentration, showed the highest reduction (50%) in peak viscosity compared to millet and sorghum ogi which showed 38 and 45% reductions respectively. The progressive reduction in peak viscosity of the foam mat dried ogi suggests inclusion complex formation between the starch in the ogi matrix and the foaming agent used. Zhou et al. [18] working with rice starch pasted with stearic acid observed a higher reduction in peak viscosity with increasing concentration of stearic acid from 0.5 to 1.5%. Many other authors have attributed the reduction in peak viscosity of starch with added lipids to the formation of amylose inclusion complex [19-21].

The break down viscosities of foam mat dried ogi samples (Table 2) were significantly ($p<0.05$) lower than those dried with cabinet dryer (Table 1). The reduction in breakdown viscosity of the ogi samples following the addition of foaming agent suggests that the foaming agent possibly formed inclusion complexes with the starch component of the mix. This seems plausible since previous studies attributed the reduction in breakdown viscosity to interaction of lipids with starch molecule enhancing greater resistance to hydrothermal disruption during gelatinization [18, 22]. Foam dried ogi, thus can withstand more thermal and shear conditions than cabinet dried types.

Table 1

Pasting properties of cabinet dried ogi

Cereal type	PV(RVU)	TV(RVU)	BV(RVU)	FV (RVU)	SV (RVU)	PT (°C)
Maize	3426.0 ^c	1973.0 ^c	1451.0 ^a	3418.5 ^b	1451.0 ^b	78.3 ^a
Millet	3589.0 ^a	2157.5 ^b	1431.5 ^b	3328.0 ^c	1169.5 ^c	79.1 ^a
Sorghum	3541.5 ^b	2385.0 ^a	1156.5 ^c	3894.0 ^a	1509.0 ^a	79.0 ^a

Mean with different superscript along the column are significantly different ($p<0.05$).

PV: Peak viscosity, TV: Trough viscosity, BV: Breakdown viscosity, FV: Final viscosity, SV: Setback viscosity, PT: Pasting temperature

Foam mat dried ogi displayed significantly ($p < 0.05$) higher final viscosity compared to the cabinet dried samples (Table 1-3). This could be attributed to the added glyceryl monostearate (GMS), which may act as a foaming agent, emulsifier and a thickener.

The pasting temperature of foam-mat dried ogi varied from approx. 80 to 95°C (Table 2), while that of cabinet dried ogi varied from approx. 78 to 79°C (Table 1). Pasting temperature is an indication of gelatinization time during processing and its represents the minimum temperature required for cooking. Pasting temperature has been reported to relate to water binding capacity [23]. A higher pasting temperature indicates higher water binding capacity, and lower swelling property of starch due to a high degree of association between starch granules [23, 24]. The relatively higher pasting temperature of foam mat dried ogi agrees well with its lower peak viscosity and suggests that the added GMS enhance stronger interaction between starch granules.

Table 2

Pasting properties of foam mat dried ogi powder

Cereal type	GMS (%)	PV (RVU)	TV (RVU)	BV (RVU)	FV (RVU)	SV (RVU)	PT (°C)
Maize	5	2623.5 ^b	1610.8 ^c	1005.5 ^a	3424.0 ^t	2152.5 ^t	80.9 ^c
Maize	10	2121.0 ^c	1509.5 ^t	611.5 ^c	3770.5 ^c	2441.0 ^c	80.7 ^c
Maize	15	1722.5 ^c	1289.5 ^c	433.0 ^c	3950.5 ^d	2128.0 ^t	90.0 ^b
Millet	5	2780.5 ^a	2038.0 ^b	742.5 ^b	4066.5 ^c	2762.5 ^d	91.7 ^b
Millet	10	2635.5 ^b	1621.0 ^c	614.5 ^c	4800.5 ^{bc}	2445.5 ^c	94.9 ^a
Millet	15	2235.5 ^c	1991.5 ^c	644.0 ^c	6144.1 ^a	4152.5 ^a	94.9 ^a
Sorghum	5	2670.5 ^b	2383.5 ^a	517.0 ^d	4685.0 ^c	4085.0 ^a	94.8 ^a
Sorghum	10	2174.5 ^c	1657.5 ^c	287.0 ^t	5260.5 ^b	3027.5 ^c	93.3 ^a
Sorghum	15	1962.5 ^d	1732.0 ^d	230.5 ^t	6468.5 ^a	3527.0 ^b	95.4 ^a

Mean with different superscript along the column are significantly different ($p < 0.05$).

GMS: Glyceryl monostearate, PV: Peak viscosity, TV: Trough viscosity, BV: Breakdown viscosity, FV: Final viscosity, SV: Setback viscosity, PT: Pasting temperature

Water absorption capacity. Irrespective of drying method, sorghum ogi showed higher water absorption capacity (WAC) than maize and millet ogi (Table 3 & 4). The WAC of cabinet dried ogi varied between 81 to 94% for millet and sorghum grains respectively (Table 3). Foam mat dried ogi samples generally showed higher WAC (Table 4) compared to the cabinet dried samples (Table 3). With increasing concentration of the foaming agent (GMS) from 5 to 15%, the WAC of foam mat dried maize ogi increased from approximately 89 to 100%, foam mat dried millet ogi increased from 85 to 93%, while that of foam mat dried sorghum ogi increased from 95 to 117%. The increase in WAC of foam mat dried ogi samples may be attributed to the possible influence of the hydroxyl group in the glycerol backbone of the GMS. Further, the polar carboxylic head of the stearic acid may also contribute to increased water absorption. In our previous study, we reported that foam mat dried ogi samples showed significantly lower moisture content than cabinet dried samples [5]. This may further explain why the foam mat dried samples showed higher WAC than cabinet dried ogi, since they are more porous and have more space for water absorption.

Table 3

Functional properties of cabinet dried ogi

Cereal type	WAC (%)	LGC (%)	DPS (%)	LBD (g/ml)	PBD (g/ml)	pH
Maize	81.5 ^b	6.0 ^b	70.0 ^b	0.5 ^b	0.8 ^b	3.8 ^a
Millet	81.0 ^b	8.0 ^a	73.0 ^a	0.6 ^a	0.9 ^a	3.7 ^a
Sorghum	94.0 ^a	6.0 ^b	72.0 ^a	0.5 ^a	0.8 ^b	3.7 ^a

Mean with different superscript along the column are significantly different ($p < 0.05$).

WAC: water absorption capacity, LGC: least gelation concentration, DPS: dispersibility, LBD: loose bulk density, PBD: packed bulk density

Table 4

Functional properties of foam mat dried ogi

Cereal type	GMS (%)	WAC (%)	LGC (%)	DPS (%)	LBD (g/ml)	PBD (g/ml)	pH
Maize	5	89.4 ^b	6.0 ^b	76.0 ^b	0.2 ^b	0.6 ^b	3.4 ^c
Maize	10	90.5 ^{bc}	6.0 ^b	72.0 ^b	0.4 ^a	0.6 ^b	3.6 ^b
Maize	15	95.5 ^c	6.0 ^b	78.0 ^a	0.4 ^a	0.6 ^b	3.5 ^c
Millet	5	85.3 ^c	8.0 ^a	78.0 ^a	0.4 ^a	0.6 ^b	4.2 ^a
Millet	10	92.8 ^b	6.0 ^b	77.8 ^a	0.4 ^a	0.6 ^b	3.7 ^b
Millet	15	92.7 ^b	6.0 ^b	77.8 ^a	0.4 ^a	0.6 ^b	3.7 ^b
Sorghum	5	94.7 ^b	8.0 ^a	72.0 ^b	0.4 ^a	0.7 ^a	3.6 ^b
Sorghum	10	104.5 ^a	6.0 ^b	78.0 ^a	0.4 ^a	0.7 ^a	3.5 ^c
Sorghum	15	117.0 ^a	6.0 ^b	78.0 ^a	0.4 ^a	0.7 ^a	3.4 ^c

Mean with different superscript along the column are significantly different ($p < 0.05$).

GMS: Glyceryl monostearate, WAC: water absorption capacity, LGC: least gelation concentration, DPS: dispersibility, LBD: loose bulk density, PBD: packed bulk density

Least gelation, dispersibility and pH. The least gelation concentration of the dried ogi was not substantially affected by drying method and cereal type (Table 3 & 4). Most of the ogi gelled at about 6% concentration suggesting that their textural properties were not significantly modified by drying method. According to Udensi and Okoronkwo [25] gelation is an important property which influences the texture of foods.

Foam mat dried ogi powder (Table 4) dispersed faster than cabinet dried samples (Table 3). The dispersibility of ogi dried by cabinet dryer varied from 70 to 73 % (Table 3), while those of foam mat dried ogi varied from 72- 78% (Table 4). Dispersibility is a measure of how individual molecules of a food sample, usually powder, are able to disperse and homogenize with medium of dispersion. The high dispersibility of foam mat dried samples may be linked with the porosity of the dried ogi powder due to the incorporated air during whipping. Foam mat dried samples generally are lighter in weight compared to samples dried by most drying methods. Previous studies by Falade and Olugbuyi [12] similarly reported higher dispersibility for foam mat dried samples compared to oven and sun dried plantain and cooking banana flours.

The pH values of dried ogi were generally low (3.4-4.2) and are within values reported in the literature [26-28].

Bulk densities. The bulk densities (loose and packed densities) of foam mat dried ogi (Table 3) were generally lower than the cabinet dried samples (Table 4). High bulk density has been suggested to indicate greater compactness of the particles [12]. Thus cabinet dried ogi are more compact than the foam mat dried ogi powder. The low bulk densities of foam mat dried ogi may not be unconnected with the high contents of occluded and interstitial air incorporated during whipping of the ogi paste. Previous studies similarly reported lower bulk densities for foam mat dried banana and plantain compared to oven and sun dried ogi powders [12, 29].

Foaming capacity. Foaming properties refers to the ability of a dispersion of protein to form a stable when air is beaten in. The foaming capacities (FC) of the cabinet dried ogi (Fig. 1) were lower than those of foam mat dried samples (Fig. 2). FC increased with increasing glyceryl monostearate concentration (GMS) for the foam mat dried ogi. This is expected since GMS is a foaming agent frequently used in several food and non-food applications.

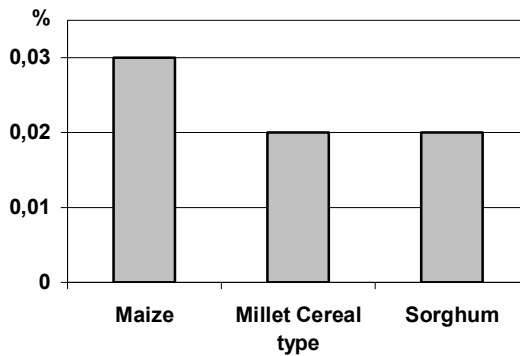

Fig. 1. Foaming capacity of cabinet dried ogi

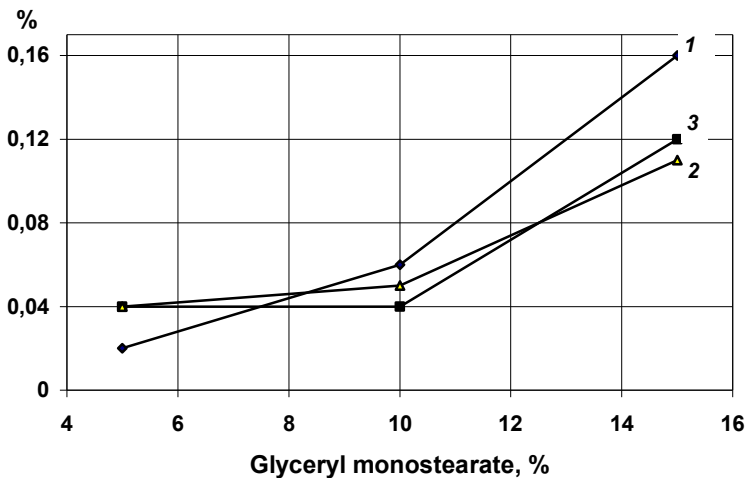

Fig. 2. Foaming capacity of foam mat dried ogi:
1 – Sorghum, 2 – Millet, 3 – Maize

Conclusions

Drying method did not influence the pH, and gelling ability of ogi prepared from maize, millet and sorghum grains. However both drying method and cereal type influenced the pasting and other functional properties of the dried ogi powder. Foam mat dried ogi display low peak viscosity which may be attributed to possible inclusion complex between starch and the foaming agent.

Cabinet dried ogi powder show greater ability to cook faster than foam-mat dried powder as indicated by low pasting temperature. Although, foam mat dried ogi powder show better water absorption capacity dispersibility, foamability, and viscosity compared to cabinet dried samples, the selection of a particular drying method for ogi will depend on the desired application.

References

1. Oyarekua M. and Eleyinmi A. (2004), Comparative evaluation of the nutritional quality of corn, sorghum and millet ogi prepared by a modified traditional technique, *Journal of Food Agriculture and Environment*, 2, pp. 94-99
2. Adeyemi I. and Beckley O. (1986), Effect of period of maize fermentation and souring on chemical properties and amylograph pasting viscosity of ogi, *Journal of Cereal Science*, 4(4), pp. 353-360
3. Aremu M., Osinfade B., Basu S., and Ablaku B. (2011), Development and nutritional quality evaluation of Kersting's groundnut ogi for African weaning diet, *American Journal of Food Technology*, 6(12), pp. 1021-1033
4. Afolayan M., Afolayan M., and Abuah J. (2010), An investigation into sorghum based ogi (Ogi-Baba) storage characteristics, *Advance Journal of Food Science and Technology*, 2(1), pp. 72-78
5. Ladunni E., Aworh O., Oyeyinka S., and Oyeyinka A. (2013), Effects of Drying Method on Selected Properties of Ogi (Gruel) Prepared from Sorghum (*Sorghum vulgare*), Millet (*Pennisetum glaucum*) and Maize (*Zea mays*), *J Food Process Technol* 4: 248. doi,
6. Falade K.O. and Okocha J.O. (2012), Foam-mat drying of plantain and cooking banana (*Musa spp.*), *Food and Bioprocess Technology*, 5(4), pp. 1173-1180
7. Ratti C. and Kudra T. (2006), Drying of foamed biological materials: opportunities and challenges, *Drying Technology*, 24(9), pp. 1101-1108
8. Kudra T. and Ratti C. (2006), Foam-mat drying: Energy and cost analyses, *Canadian Biosystems Engineering*, 48, pp. 3
9. Mpotokwane S., Gaditlhatlhelwe E., Sebaka A., and Jideani V. (2008), Physical properties of bambara groundnuts from Botswana, *Journal of food engineering*, 89(1), pp. 93-98
10. Oyeyinka S.A., Oyeyinka A.T., Karim O.R., Kayode R.M.O., Balogun M.A., and Balogun O.A. (2013), Quality attributes of weevils (*Callosobruchus Maculatus*) infested cowpea (*Vigna unguiculata*) products, *Journal of Agriculture Food and Environment* 9(3), pp. 16-22
11. Sathe S.K., Rangnekar P.D., Deshpande S.S., and Salunkhe D.K. (1982), Isolation and partial characterization of black gram (*Phaseolus mungo* L) starch, *Journal of Food Science*, 47(5), pp. 1524-1538
12. Falade K.O. and Olugbuyi A.O. (2010), Effects of maturity and drying method on the physico-chemical and reconstitution properties of plantain flour, *International journal of food science & technology*, 45(1), pp. 170-178

13. AOAC, *Official methods of analysis. 17th edition.* 2000, Association of official Analytical Chemists, Rockville.
14. Huang J., Shang Z., Man J., Liu Q., Zhu C., and Wei C. (2015), Comparison of molecular structures and functional properties of high-amylose starches from rice transgenic line and commercial maize, *Food Hydrocolloids*, 46, pp. 172-179
15. Tester R.F. and Morrison W.R. (1990), Swelling and gelatinization of cereal starches. I. Effects of amylopectin, amylose, and lipids, *Cereal chemistry*, 67(6), pp. 551-557
16. Osungbaro T.O. (1990), Effect of fermentation period on amylose content and textural characteristics of “Ogi”(a fermented maize porridge), *Journal of Fermentation and Bioengineering*, 70(1), pp. 22-25
17. Osungbaro T.O. (1990), Effect of differences in variety and dry milling of maize on textural characteristics of ogi (fermented maize porridge) and agidi (fermented maize meal), *Journal of the Science of Food and Agriculture*, 52(1), pp. 1-11
18. Zhou Z., Robards K., Helliwell S., and Blanchard C. (2007), Effect of the addition of fatty acids on rice starch properties, *Food Research International*, 40(2), pp. 209-214
19. Ocloo F.C., Minnaar A., and Emmambux N.M. (2016), Effects of stearic acid and gamma irradiation, alone and in combination, on pasting properties of high amylose maize starch, *Food Chemistry*, 190, pp. 12-19
20. Tang M.C. and Copeland L. (2007), Analysis of complexes between lipids and wheat starch, *Carbohydrate Polymers*, 67(1), pp. 80-85
21. D’Silva T.V., Taylor J.R., and Emmambux M.N. (2011), Enhancement of the pasting properties of teff and maize starches through wet-heat processing with added stearic acid, *Journal of Cereal Science*, 53(2), pp. 192-197
22. Kim C. and Walker C. (1992), Changes in starch pasting properties due to sugars and emulsifiers as determined by viscosity measurement, *Journal of Food Science*, 57(4), pp. 1009-1013
23. Eniola L. and Delarosa L. (1981), The introduction of SPF into WF for bakery characterizes of yam starches, *Journal of Food Biochemistry*, 5, pp. 115-130
24. Numfor F.A., Walter W.M., and Schwartz S.J. (1996), Effect of emulsifiers on the physical properties of native and fermented cassava starches, *Journal of Agricultural and Food Chemistry*, 44(9), pp. 2595-2599
25. Udensi, E. and Okoronkwo K. (2006), Effects of fermentation and germination on the physicochemical properties of Mucuna cochinchinensis protein isolate, *African Journal of Biotechnology*, 5(10), pp. 896-900
26. Wakil S. and Kazeem M. (2012), Quality assessment of weaning food produced from fermented cereal-legume blends using starters, *International Food Research Journal*, 19(4), pp. 1679-1685
27. Sanni A., Onilude A., and Ibidapo O. (1999), Physicochemical characteristics of weaning food formulated from different blends of cereal and soybean, *Zeitschrift für Lebensmitteluntersuchung und-Forschung A*, 208(3), pp. 221-224
28. Sanni A., Lönner C., Marklinder I., Johansson M., and Molin G. (1994), Starter cultures for the production of Ogi, a fermented infant food from maize and sorghum, *Chemie, Mikrobiologie, Technologie der Lebensmittel*, 16(112), pp. 29-33
29. Falade K.O. and Oyeyinka S.A. (2014), Color, Chemical and Functional Properties of Plantain Cultivars and Cooking Banana Flour as Affected by Drying Method and Maturity, *Journal of Food Processing and Preservation*, 39(6), pp. 816-828.

Kinetics of hydrolysis-extraction of pectin substances from the potato raw materials

Olena Hrabovska¹, Hanna Pastukh¹, Oksana Demenyuk¹,
Volodymyr Mirosnyk², Tetyana Halatenko¹,
Alina Babii¹, Alina Dobrydnuk¹

1 – National university of food technologies, Kyiv, Ukraine

2 – National university of bioresources and nature management, Kyiv, Ukraine

Abstract

Keywords:

Pectin
Kinetics
Hydrolysis
Extraction
Potato
Pulp

Article history:

Received 02.10.2015
Received in revised
form 19.12.2015
Accepted 24.12.2015

Corresponding author:

Olena Hrabovska
E-mail:
helengrabovski@ukr.net

Introduction. Hydrolysis-extraction of pectin substances from plant raw materials is one of the most difficult and the most important processes of pectin obtaining technology. Therefore, the study of the technological parameters influence on the kinetics of this process is relevant.

Materials and methods. The subject of the study was the process of hydrolysis-extraction of pectin from the potato pulp using hydrochloric acid. Pectin yield was determined in the percentage by weight of dry matter. Kinetic constants were calculated by the first-order equation. The processing of experimental data, equations selection, calculation and refinement of coefficients of these equations were performed by means of the least squares method.

Results and discussion. On the basis of experimental studies kinetic curves of the process of hydrolysis-extraction of pectin from the potato pulp are built, depending on temperature and pH. PH of the surrounding has the greatest influence on the rate of hydrolysis protopectin. For low acid content as a catalyst for the process, the reaction rate is not significant even at high temperatures. Protopectin hydrolysis is accompanied by a number of adverse reactions connected with the destruction of pectin, which makes it difficult to determine the reaction rate constant. Through experiment planning and statistical processing of experimental data the optimal parameters of hydrolysis-extraction of potato pectin are determined: temperature of 75°C, pH of hydrolysis weight is 1.6; hydrolysis duration is 72 minutes.

Conclusions. Application of results of researches during pectin production provides maximum extraction of pectin without damaging its structure.

Introduction

Hydrolysis-extraction of pectin from plant raw materials is one of the most difficult and the most important processes of pectin obtaining technology.

Pectin in the cell walls is found in two basic forms: soluble pectin (pectin) and insoluble pectin (protopectin), which is a complex of cellulose with pectin. During hydrolytic processing of raw materials in the presence of catalysts, protopectin is more subjected to destruction, hemicellulose is less subjected to destruction, and cellulose undergoes minor destructive influence [2].

Protopectin hydrolysis is carried out by means of catalysts of various types: alkali (sodium hydroxide and potassium), mineral acids (sulfuric, hydrochloric, nitric, phosphoric), organic acids (oxalic, lemon), their different combinations and concentrations [2, 3], enzymes (cellulases, amylases, pectinases). Extraction of insoluble pectin from plant raw materials is held in two stages. During the first stage – under aqueous solutions of mineral and organic acids or other hydrolyzing reagents protopectin is hydrolyzed in pectin soluble form. During the second stage – soluble pectin molecules are diffused into the solution of the raw materials, i.e. extraction. Usually during the hydrolysis of plant raw materials in the presence of acid, these processes take place simultaneously. It should be noted that along with the basic protopectin hydrolysis reaction there is a number of adverse reactions related to the partial hydrolysis of the most polymer pectin chains with the formation of hydrolysis products of different molecular weight.

Traditional technology of pectin, regardless of the type of raw materials, is based on protopectin acid hydrolysis at raised temperature [3]. A number of factors, except the nature of hydrolyzing agent, influence the process of pectin hydrolysis-extraction: temperature, pH of the surrounding, duration of the process. Therefore, the study of kinetics of pectin hydrolysis-extraction from plant raw is relevant.

The purpose of the research was to investigate the kinetic regularities of hydrolysis-extraction process and establish optimal technological conditions of potato pectin extraction, bring mathematical dependence that will optimize the process of raw materials hydrolysis.

Materials and methods

During the study we used potato pulp (72% moisture), previously rinsed from starch.

Pectin extraction was carried through successive stages: acid-thermal hydrolysis-extraction using hydrochloric acid, separation of the liquid phase from the solid one, neutralization of pectin extract, pectin precipitation by ethanol, drying and milling of the ready pectin.

Number of hydrochloric acid solution, as hydrolytic factor, was added according to the set pH of hydrolysis mixture and taking into account hydrological module of hydrolysis. Hydrological module of hydrolysis (q), which is defined by the ratio of weight of the acid solution to the mass taken for hydrolysis of raw potato, was set equal to 2. Yield of the target product (%) was calculated relative to the mass of dry matter (DM).

According to literature data, reaction of hydrolysis-extraction of pectin substances from plant tissues occurs according to kinetic first-order equation. Kinetics equation used to describe hydrolysis [2, 5]:

$$\frac{dx}{d\tau} = K(a - x) \quad (1)$$

where x – amount of substance reacted to a given point in time; a – original amount of substance; τ – time of hydrolysis; K – reaction rate constant.

The rate constant for this reaction is determined by the formula:

$$K = \frac{1}{\tau} \ln \frac{a}{a - x} \quad (2)$$

Unlike the reaction rate (v), reaction rate constant K does not depend on concentration for this reaction at a given temperature and may characterize this reaction.

Results and discussion

By means of experiment planning a series of studies on the extraction of pectin from potato pulp through acid-thermal hydrolysis have been previously held, their results were analysed and taken into account, statistical processing of experimental data have been conducted that made it possible to determine the optimal parameters of the process [1].

With the aim to study the kinetics of the process of hydrolysis-extraction of pectin from the potato pulp a series of experiments for pectin extraction at different pH values (0,6; 1,6; 2) and at the temperature of 60, 70 80 i 90°C are held. Ratio of liquid and solid phases during the process is as 2:1. Selection of parameters is conditioned by previous studies. During hydrolysis every 20 min samples were analyzed for ethanolprecipitated content of pectin in % by weight of dry matter. For this purpose, the liquid phase was separated, neutralized to pH 3.5 and precipitated pectin by ethanol if added in a ratio, respectively: 1:2. Pectin was dehydrated, dried to a constant weight and weighed. Based on the data received, kinetic curves of hydrolysis-extraction of pectin from the potato raw materials at different temperatures and pH were built (Fig.1).

Kinetic curves of hydrolysis-extraction of pectin from the potato raw materials are built according to yield index of ethanolprecipitated pectin (%) at each time and characterize protopectin hydrolysis of plant raw materials and the transition of soluble pectin into the extract. However, in the strict conditions of hydrolysis there are simultaneous and undesirable reactions connected with subsequent hydrolytic cleavage of pectin macromolecules. Reducing the molecular weight of pectin as a result of destruction leads to minimization of pectin yield which is precipitated by ethanol. That is why, if pH of the surrounding is 0.6 (Fig. 1 a) at the beginning of hydrolysis process, the yield of ethanolprecipitated pectin substance increases. The reaction of rate hydrolytic cleavage of protopectin is the largest. When the temperature increases the rate of all reactions increases, therefore at a temperature of 80° C and 90° C pectin yield reaches 40-50% by weight of dry matters. With the increase of duration of the process pectin yield decreases sharply, whereas reactions of depolymerization, deetherification and deacetylation of pectin macromolecules accelerate simultaneously [3], i.e. pectin destruction and therefore further reduction of the amount of ethanolprecipitated pectin substances [4].

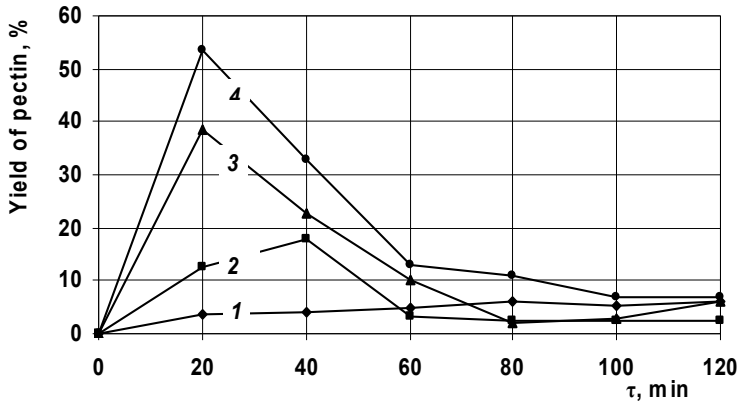

a

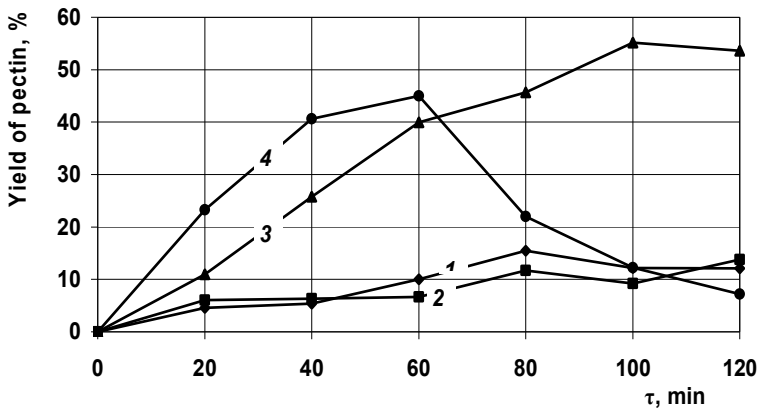

b

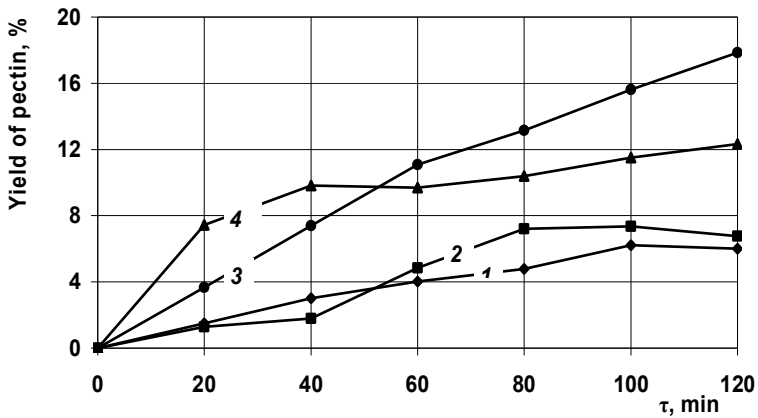

c

Fig.1. Kinetic curves of hydrolysis-extraction of pectin from the potato raw materials at different temperatures and pH: a – pH 0,6; b – pH 1,6; c – pH 2. 1 – 60°C; 2 – 70°C; 3 – 80°C; 4 – 90°C.

At larger pH of the surrounding (pH 1,6) (Fig.1, b) the largest pectin yield at the temperature of 80° C and duration of the process 100 min. Reaction of insoluble protopectin hydrolysis also slows down at the temperatures of 60 and 70° C pectin yield increases slightly. At high temperature (90° C) destructive processes prevail and pectin yield at duration of the process over 60 minutes reduces. Increasing of the pH of the surrounding to 2 significantly reduces the rate of protopectin hydrolysis reaction (Fig. 1, c). With the increase of duration of the process to 120 min. the increase of pectin yield is only to 18%. Thus, it is not effective for hydrolysis of this raw material to conduct a process at pH 2.

Reaction rate constant is a constant at a given temperature and may characterize this reaction. The largest reaction rate constant of protopectin hydrolysis is while using hydrochloric acid, and the lowest – while using lemon acid. Furthermore, the kinetic constant is different for different raw materials [2]. For a more complete understanding of the reaction rate of protopectin hydrolysis of potato raw materials at different temperatures and pH we have calculated value of the reaction rate constant in each period by the formula 2.

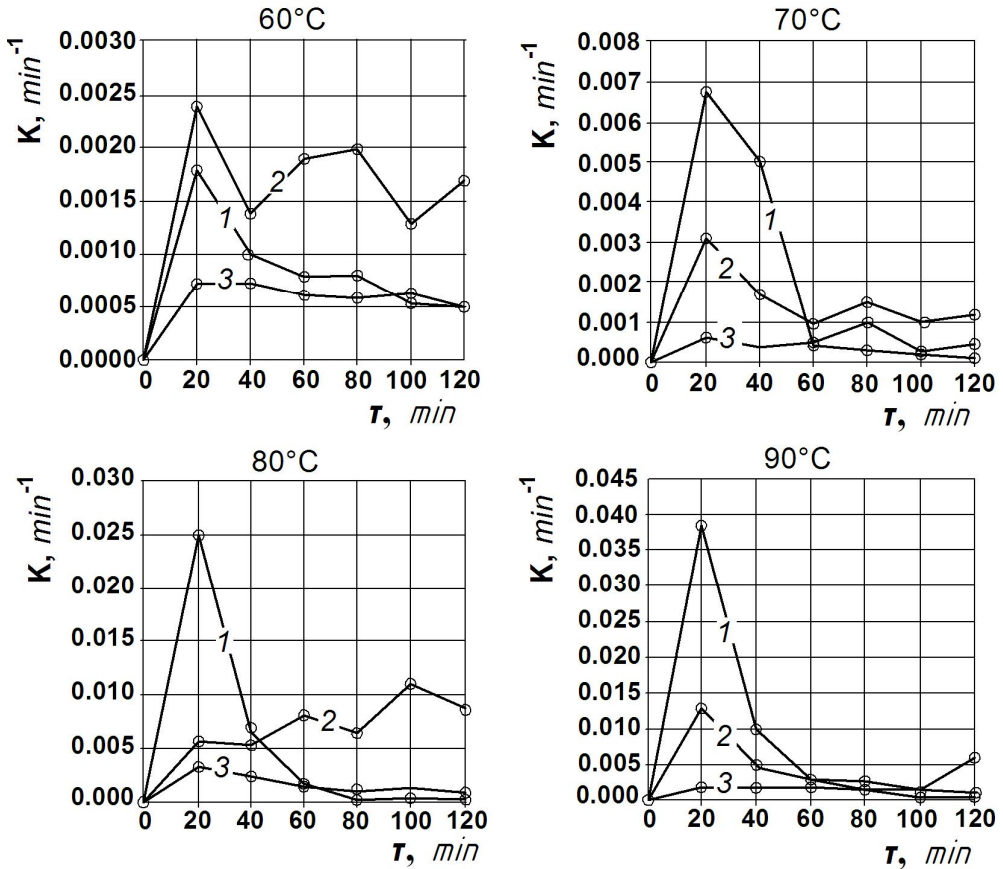

Fig.2 Dependence of the rate constant of hydrolysis-extraction of pectin substances of potato raw materials on temperature.
1 – pH 0.6; 2 – pH 1.6; 3 – pH 2.0

As we can from the Fig. 2 at increasing temperature of process to 80° C value of the reaction rate constant increases, however, at further temperature increase to 90° C (excluding pH 0,6) a decrease in the hydrolysis rate constant because of the increasing of destructive processes takes place. Such fluctuations in the values of kinetic constants indicate a course of parallel reactions that significantly affect the course of the main reaction reducing yield and quality of pectin. When reducing pH from 2 to 0.6 the rate of hydrolysis increases. However, this affects the quality of pectin indices. Because of the acid activity increasing and pH lowering, the hydrolysis rate of protopectin and other compounds (starch, protein, hemicellulose, cellulose) increases [4]. Macromolecular hydrolysis products of these substances are co-precipitated with pectin, thus increasing the overall yield, but the pectin purity (uronid component) decreases. Thus, pH of the surrounding has the greatest impact on reaction rate of protopectin hydrolysis. For low acid content as the process catalyst, even at high temperatures, the reaction rate is not significant. Experimental data processing, selection of equations, calculation and refinement of coefficients of these equations were implemented by means of the method of least squares. As a result, the following equations of local optimization criteria were obtained for each value of pH: 1 – for pH 0,6; 2 – for pH 1,6; 3 – for pH 2,0.

$$P(t, \tau) = e^{37,217-2,264 \cdot t+0,038 \cdot t^2-2,64 \cdot 10^{-5} \cdot t^3} \cdot \tau^{6,54-0,28 \cdot t+5 \cdot 10^{-3} \cdot t^2-2,65 \cdot 10^{-5} \cdot t^3} \times e^{(-2,56+0,13 \cdot t-2,09 \cdot 10^{-3} \cdot t^2+1,062 \cdot 10^{-5} \cdot t^3) \cdot \tau+(0,028-1,27 \cdot 10^{-3} \cdot t+1,89 \cdot 10^{-5} \cdot t^2-9,065 \cdot 10^{-8} \cdot t^3) \cdot \tau^2} \quad (1)$$

$$P(t, \tau) = e^{-117,4+4,64 \cdot t-0,062 \cdot t^2+2,79 \cdot 10^{-4} \cdot t^3} \cdot \tau^{-14,632+0,67 \cdot t-9 \cdot 10^{-3} \cdot t^2+4,028 \cdot 10^{-5} \cdot t^3} \times e^{(9,86-0,4 \cdot t+5,428 \cdot 10^{-3} \cdot t^2-2,4 \cdot 10^{-5} \cdot t^3)+(-0,05+1,86 \cdot 10^{-3} \cdot t-2,46 \cdot 10^{-5} \cdot t^2+1,06 \cdot 10^{-7} \cdot t^3) \cdot \tau^2} \quad (2)$$

$$P(t, \tau) = e^{348,96-14,69 \cdot t+0,2 \cdot t^2-9,01 \cdot 10^{-4} \cdot t^3} \cdot \tau^{52,97-2,13 \cdot t+0,03 \cdot t^2-1,31 \cdot 10^{-4} \cdot t^3} \times e^{(-10,27+0,43 \cdot t-0,006 \cdot t^2+2,65 \cdot 10^{-5} \cdot t^3) \cdot \tau+(0,05-0,002 \cdot t+2,96 \cdot 10^{-5} \cdot t^2-1,34 \cdot 10^{-7} \cdot t^3) \cdot \tau^2} \quad (3)$$

Experimental data processing, selection of equations, calculation and refinement of coefficients of these equations were performed by means of package of applied programs Mathcad Professional 2000 using the method of least squares. Based on the data obtained according to yield of pectin, using the program of process optimization lines of level of generalized optimization criterion were received, which allow finding the optimal parameters values of the process of hydrolysis-extraction of pectin from the potato raw materials (Fig. 3).

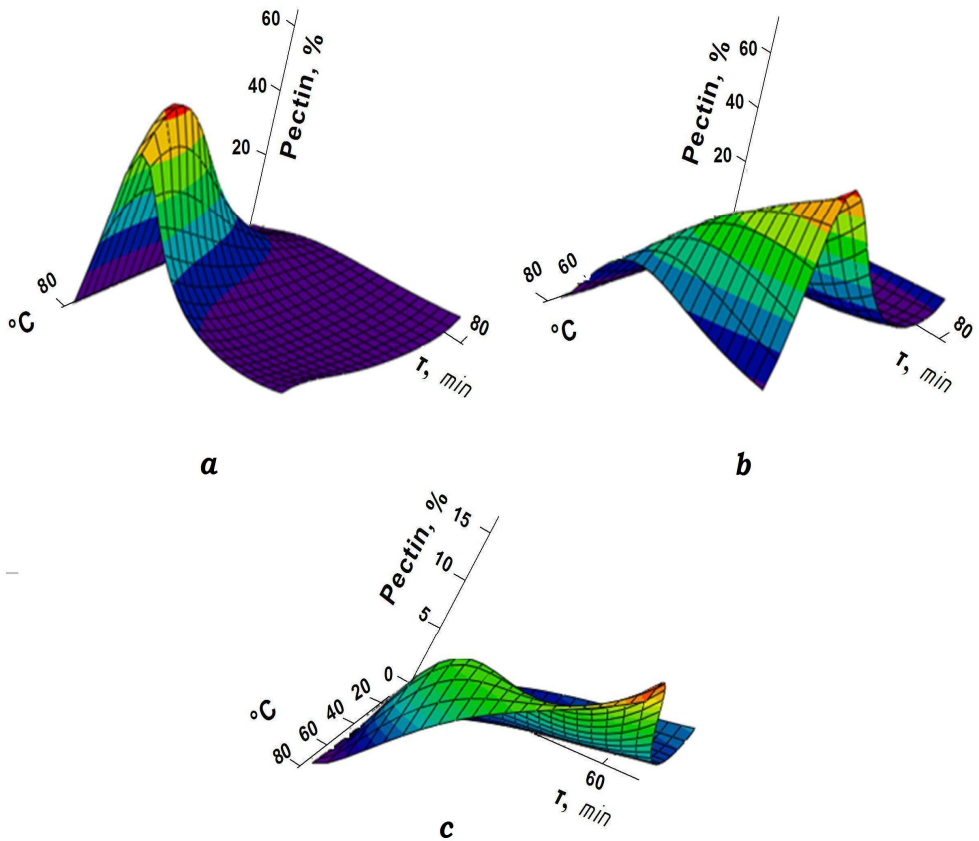

Fig. 3. Response area of optimal parameters of pectin extraction while changing the duration and temperature of the process:
a - pH 0,6; b - pH 1,6; c - pH 2,0

By means of a mathematical model the parameters of optimal technological regime of pectin extraction from potato pulp are defined: temperature of 75°C, pH of hydrolysis weight – 1,6; hydrolysis duration – 72 min. Under these parameters pectin extraction is maximum without damaging its structure. Also, these data are consistent with the previous researches.

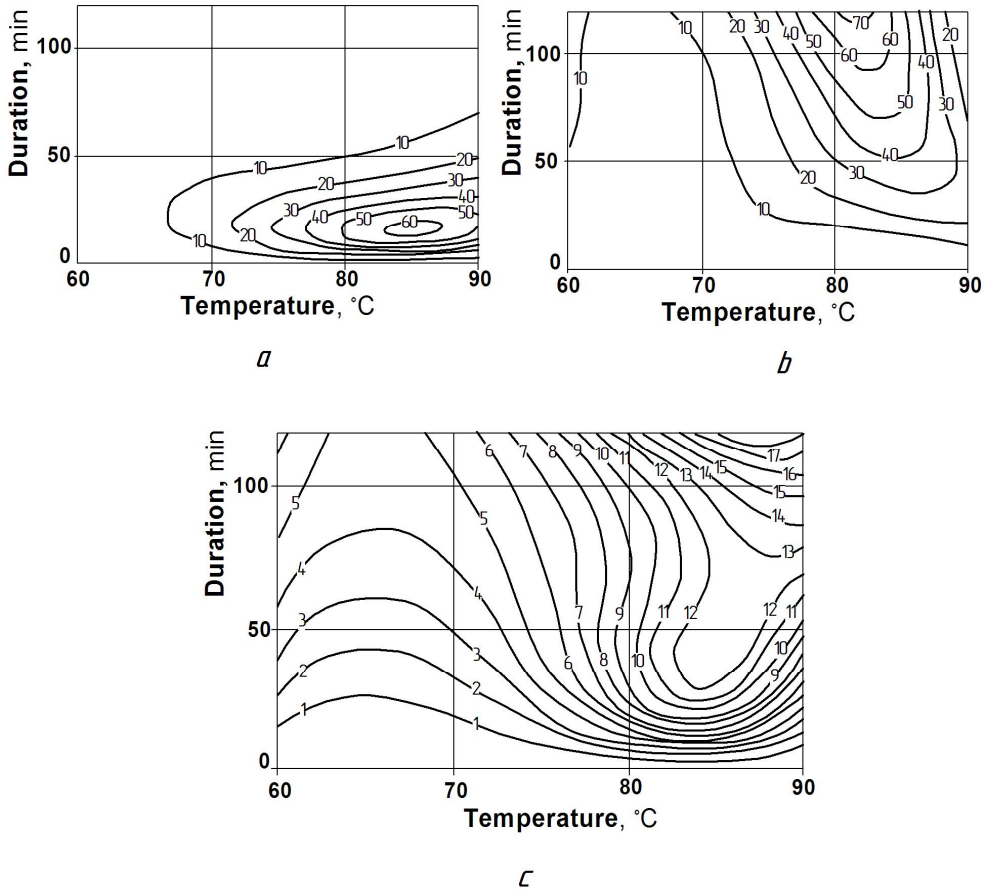

Fig. 4. Lines of optimal parameters level of pectin extraction while changing the duration and temperature of the process:
a - pH 0,6; b - pH 1,6; c - pH 2,0

Conclusion

On the basis of experimental and theoretical studies the optimal parameters of hydrolysis-extraction pectin from potato raw materials are determined: temperature of 75°C, pH of hydrolysis weight – 1,6; hydrolysis duration – 72 min. Mathematical model of this process is elaborated.

References

1. Olena Hrabovska, Hanna Pastukh, Veronika Moiseeva, Volodymyr Miroshnyk (2015), Potato pectin: extract methods, physical and chemical properties and structural features, *Ukrainian Food Journal*, 4(1), pp.7-13.
2. Pastukh H.S., Hrabovska O.V., Miroshnyk V.O. (2013), Optimization of Technological Parameters of Pectin Extraction from Potato, *Scientific Researches of NUFT*, pp.109-114.
3. Il'ina I. (2001), Nauchnye osnovy tehnologii modifitsirovannyh pektinov, RASHN, Krasnodar.
4. Golubev V. N., Shelukhina N. P. (2005), *Pectin: Chemistry, Technology, Use*, Moscow.
5. Donchenko L.V., Firsov G.G. (2007), *Pektin: osnovnye svoistva, proizvodstvo i primenenie (Pectin: Basic Properties, Production, and Application)*, Moscow.
6. Jaramillo-Flores M.E., Gonzales-Crus L., Cornejo-Mazon M., Dorantes-Alvarez L., Gutierrez-Lopez G. F. (2003), Effect of Thermal Treatment on the Antioxidant Activity and Content of Carotenoids and Phenolic Compounds of Cactus Pear *Cladodes* (*Opuntia ficus-indica*), *J. Food Science and Technology International*, 9, pp. 273.
7. Kaak K., Pedersen L., Nygaard Laerke H., Meyer A. (2006), New improvement of texture and colour of wheat bread, *Eur Food Res Technol*, 224, pp. 199-207.
8. Khatko Zh. N. (2008), Infrared Spectra of Beet Pectin., *New Technologies*, 5, pp. 39-46.
9. Lesiecki M., Białas W., Lewandowicz G. (2012), Enzymatic hydrolysis of potato pulp. *Acta Scientiarum Polonorum, Technol. Aliment*, 11(1), pp. 53-59.
10. Sorensen S.O. (2000), Pectin engineering: Modification of potato pectin by in vivo expression of an endo-1,4-b-D-galactanase, *PNAS*, 97(13), pp. 7639–7644.
11. Siti Nurdjanah (2013), Galacturonic Acid Content and Degree of Esterification of Pectin from Sweet Potato Starch Residue Detected Using ¹³C CP/MAS Solid State NMR, *European Journal of Food Research & Review*, 3(1), pp. 16-37.
12. Salvador D.L. (2000), Monosaccharide composition of sweet potato fiber and cell wall polysaccharides from sweet potato, cassava, and potato analyzed by the high performance chromatography with pulse amperometric detection method, *J. Agric. Food Chem.*, 48, pp. 3448-3454.
13. Schick R., Klinkowski M. Die Kartoffel (1961), *VEB Deutscher Landwirtschaftsverlag*, Berlin.

Post-storage qualities of pre-treated dried red bell pepper

Michael Mayokun Odewole¹, Zainab Oyinlola Ayodimeji¹,
Kehinde Peter Alabi²

1-Department of Food and Bioprocess Engineering, Faculty of Engineering and Technology, University of Ilorin, PMB 1515, Ilorin, Kwara State, Nigeria.

2-Department of Food, Agriculture and Bio-Engineering, College of Engineering and Technology, Kwara State University, PMB 1530, Malete, Nigeria.

Abstract

Keywords:

Red bell pepper
Storage
Pre-treatment
Vitamin
Qualities

Article history:

Received 05.09.2015
Received in revised
form 27.10.2015
Accepted 24.12.2015

Corresponding author:

Michael Mayokun
Odewole
E-mail:
odewole2005@
yahoo.com

Introduction. Fresh red bell pepper is highly perishable. Hence, it can be pre-treated, dried and stored for shelf life extension. In the storage facility, stored products' nutrients may depreciate and may be subjected to microbial activities.

Materials and methods. Glass ware desiccator, Lovibond colour reference standard (ISO 9002 AOCS tintometer, Pt-Co (platinum – cobalt) colour 30 reference), incubator (Model no: DHG 1923A), measuring cylinders, conical flasks, pipette, burette, separating funnel, test tubes and petri dishes; and samples of pre-treated dried red bell pepper. Nutritional analysis and bacterial load determination of samples were done respectively in the laboratory. Statistical analysis of all data obtained was done.

Results and discussion. From the table of analysis of variance, only colour had all its inputs and their various interactions not significant at $p \leq 5\%$ while all the inputs and their various interactions had significant effect on vitamin C. The results also showed that the percentage drop in the values of vitamins A and C before and after storage at various levels of process conditions were 53.10% and 53.40% respectively. The bacteria load was not above 6×10^6 cfu/ml which is within the accepted range (10^7 cfu/ml and 10^8 cfu/ml) for ready-to-eat vegetables. There was also a better retention of colour (deep yellow) in the stored pre-treated dried samples well above untreated samples with deep brown colour. T-test done showed that there was significant difference between the amount of vitamins A and C before and after storage. All the above observations from the results could be due to various factors like environmental conditions and type of the storage medium, nature of fresh samples during growth and at the time of harvest, and handling operations before, during and after processing and storage, processing conditions of samples before storage, duration of samples in storage medium and so on. Regression equations were developed for vitamins A and C, bacteria load and colour. Only vitamin A equation did not predict well.

Conclusions. The stored pre-treated dried samples of red bell pepper were microbiologically and nutritionally safe for consumption after 20 months in storage. They also showed better colour (deep yellow). The regression equations developed can be used to predict vitamin C, bacteria load and colour.

Introduction

Bell peppers (also known as sweet peppers) are plump, bell-shaped vegetables featuring either three or four lobes. They are native to Mexico, Central America and Northern sides of South America and are available in various colours such as green, red, yellow, orange and more rarely, white, rainbow (between stages of ripening) and purple [1]. Red bell peppers are rich in vitamin C and vitamin A. Since red bell peppers are high in vitamin A, they support healthy eyesight, especially night vision. They also have the ability to heal fever and cold, cure diabetes, control the cholesterol level in the body [2], heal sores and bruises and enhance food digestion [1,3]. Generally, fresh red bell pepper is highly perishable; hence, depending on the effectiveness of the storage facility and other factors, stored products' nutrients may depreciate and may be subjected to microbial activities.

Osmotic dehydration pre-treatment is the partial removal of water from food products by immersing the food in a hypertonic solution [4]. Osmotic dehydration favours colour and flavour retention, improves texture and rehydration properties and the process is simple and economical [5]. Pre-treatment is done to preserve flavour and colour, minimise nutrient loss, stop enzyme action and extend shelf life of red bell pepper. However, while in storage, pre-treated dried red bell pepper may deteriorate in quality and quantity due to various factors like environmental conditions and type of the storage medium, nature of fresh samples during growth and at the time of harvest, and handling operations before, during and after processing and storage, processing conditions of samples before storage, duration of samples in storage medium and so on.

Storing of food has several advantages which include: enabling a better balanced diet throughout the year, preserving pantry food, such as spices or dry ingredients like rice and flour for eventual use in cooking; preparedness for catastrophes, emergencies and periods of food scarcity or famine, and protection from animals or theft [6]. Storage also protects the quality of perishable and semi-perishable products from deterioration and helps in the stabilization of prices by adjusting demand and supply [7]. An in depth literature search revealed that much work has not been done on the post-storage qualities and characteristics of osmotic dehydrated (as a pre-treatment) coupled with hot air dried products, especially, red bell pepper. Therefore, the main objective of this research was to study the post-storage qualities of pre-treated dried red bell pepper with reference to; osmotic process duration, osmotic solution temperature and osmotic solution concentration. The specific objectives were to: (i) investigate the effect of these osmotic process conditions on the nutritional qualities (vitamin A and vitamin C), sensory quality (colour) and bacteria load; (ii) compare the nutritional level of pre-treated dried red bell pepper in terms of vitamin C and vitamin A before and after storage; and (iii) develop regression equations for predicting the vitamin C, vitamin A, colour and bacteria load of pre-treated dried red bell pepper after storage.

Materials and methods

Experimental equipment and materials. The following equipment were used for the study: glass ware desiccator, Lovibond colour reference standard (ISO 9002 AOCS tintometer, Pt-Co (platinum – cobalt) colour 30 reference), incubator (Model no: DHG 1923A), measuring cylinders, conical flasks, pipette, burette, desiccator, separating funnel, test tubes and petri dishes. The main materials used were 192 samples of pre-treated and 20 untreated (control) dried red bell pepper.

Storage of pre-treated dried samples. Samples (pre-treated dried red bell pepper) were stored for 20 months in a glass ware desiccator in accordance with a 4³ factorial experiment in Randomized Complete Block Design (RCBD) used for the pre-treatment of samples and final drying at 60°C. This experimental design was used by [8] to carry out the osmotic dehydration pre-treatment of samples before drying it in a convective hot air dryer fabricated by [9]. The osmotic dehydration pre-treatment factors taken into consideration were osmotic process duration (A), osmotic solution concentration (B) and osmotic solution temperature (C). The osmotic process duration used were 60 min, 90 min, 120 min and 150 min. osmotic solution concentrations were 5% (w/w), 10% (w/w), 15% (w/w) and 20% (w/w) while the osmotic solution temperatures were 30°C, 40°C, 50°C and 60°C. The moisture content of all samples before storage was not greater than 8 % (db). Also, the mean values of vitamin C and vitamin A contents of the samples before storage were 124.63 mg/100g 1.41 mg/100g respectively. The average ambient conditions of the storage environment were 28°C temperature and 46.50 % relative humidity.

Quality analysis. Vitamin A and vitamin C were analysed in the Chemistry Laboratory of the University of Ilorin, Kwara State, Nigeria using [10] standard. The bacterial load determination was done at the Microbiology Laboratory of University of Ilorin, Ilorin, Nigeria according to the procedure in the Laboratory manual of Microbiology by [11].

Colour evaluation was done using Lovibond colour reference standard with Platinum – Cobalt colour 30 reference and the results were expressed as Y, BY, B and DY, where Y was used to denote yellow, BY was used to denote brownish yellow, B for brown and DY denoted deep yellow.

Statistical analysis. All the data obtained from the laboratory were introduced into SPSS 20.0.0 software package. Statistical Analysis of Variance (ANOVA) was used to check the significance of the results. Duncan’s New Multiple Range Test (DNMRT) was also used to separate means and to rank the mean values of outputs at different levels of process conditions. The data obtained for vitamin A and vitamin C were subjected to T-test to compare the amount of vitamin A and vitamin C present before and after storage. A significant level (p value) of 5% was used at all cases.

The equation used for the T-test is shown in equations 1-3 [12].

$$T = \frac{\bar{x}_1 - \bar{x}_2}{\sqrt{\frac{S_p^2}{n_1} + \frac{S_p^2}{n_2}}} \quad (1)$$

where:

Combinet variance

$$S_p^2 = \frac{(n_1 - 1)S_1^2 + (n_2 - 1)S_2^2}{n_1 + n_2 - 2} \quad (2)$$

Variance

$$S^2 = \frac{\sum (x - \bar{x})^2}{n - 1} \quad (3)$$

Number of samples n =64.

Null Hypothesis (H₀). There is no significant difference in the amount of vitamin A and vitamin C of pretreated dried red bell pepper before storage and after storage.

Alternate hypothesis (H₁). There is significant difference in the amount of vitamin A and vitamin C of pretreated dried red bell pepper before and after storage.

Decision Rule:

Reject H₀ if calculated t- value is \geq Table or critical value.

Accept H₁ if calculated t-value is \geq Table or critical value.

Vitamin A. Number of samles before storage n₁ and after storage n₂:

$$n_1=n_2=64$$

Mean before storage:

$$\bar{x}_1 = 1.41$$

Mean after storage:

$$\bar{x}_2 = 0.66$$

Variance before storage:

$$S_1^2 = 0.000587$$

Variance after storage:

$$S_2^2 = 0.000798$$

Vitamin C. Number of samles before storage n₁ and after storage n₂:

$$n_1=n_2=64$$

Mean before storage:

$$\bar{x}_1 = 124.63$$

Mean after storage:

$$\bar{x}_2 = 58.08$$

Variance before storage:

$$S_1^2 = 86.49$$

Variance after storage:

$$S_2^2 = 4.84$$

Developments of regression equations. In developing the regression equations, about 80% of the data obtained were introduced into SPSS 20.0.0 software package and the rest of the data were used for testing the regression equations. The regression equations developed were tested with respect to their p-values and difference between the predicted and observed values of outputs.

Results and discussion

Results of analysis of variance (ANOVA). The results of analysis of variance (ANOVA) showing the effect of osmotic process duration, osmotic solution temperature and osmotic solution concentration on vitamin C, vitamin A, bacteria load and colour is presented in Table 1. It can be inferred from Table 1 that only colour had all its inputs and their various interactions not significant at $p \leq 5\%$ while all the inputs and their various interactions had significant effect on vitamin C. The implication of this observation is that all the process conditions and their interactions did not cause a noticeable effect on the colour of the pretreated dried product after storing them for 20 months.

Table 1

Results of Analysis of Variance for Outputs

Inputs				Interactions			
Outputs	A	B	C	A×B	A×C	B×C	A×B×C
Bacteria Load, 10 ⁶ cfu/ml	0.00*	0.00*	0.00*	0.01*	0.51	0.00*	0.00*
Vitamin C, mg/100g	0.00*	0.00*	0.00*	0.00*	0.00*	0.00*	0.00*
Vitamin A, mg/100g	0.00*	0.00*	0.00*	0.00*	0.00*	0.14	0.00*
Colour	0.64	0.42	0.20	0.36	0.61	0.73	0.47

*Significant at P ≤ 5%

A - Osmotic Process Duration (minutes), B- Osmotic Solution Concentration , %(w/w),
C- Osmotic Solution Temperature, °C.

Effect of osmotic process duration, osmotic solution concentration and osmotic solution temperature on bacteria load. The effect of osmotic process conditions on bacteria load is shown in Figure 1. The highest bacteria load (6×10⁶cfu/ml) was at 90 minutes osmotic process duration, 60°C osmotic solution temperature and 20 % w/w osmotic solution concentration and the lowest bacteria (1.20×10⁶cfu/ml) was at these combinations; 30°C osmotic solution temperature, osmotic solution concentration 10% w/w and osmotic process duration 90 minutes. It has been reported that bacteria or other microorganisms require nutrients for growth; hence the irregularities in the bacteria load could be as a result of the difference in the amount of nutrients present in the various samples [13]. Also, [14] proposed 10⁸cfu/ml of aerobic psychotropic bacteria and 10⁷cfu/g for lactic acid bacteria as the limiting criteria for ready-to-eat vegetables. The result obtained for bacteria load is within these limiting criteria.

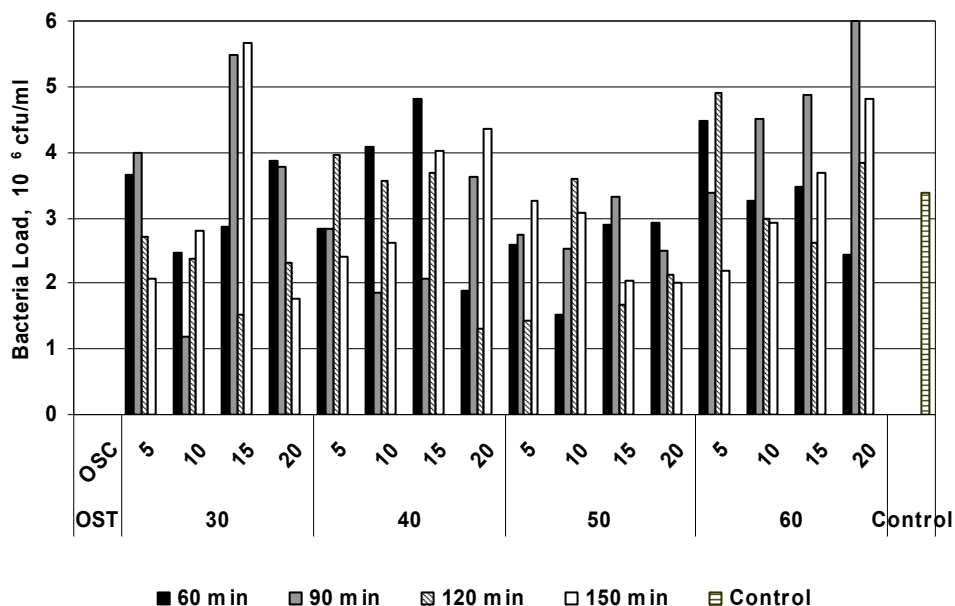

Figure 1. Effect of osmotic process duration, osmotic solution temperature and osmotic solution concentration on bacteria load

Table 2 presents the effect of individual process conditions on the mean values of bacteria load of stored pre-treated dried red bell pepper. The highest mean value of bacteria load (3.71×10^6 cfu/ml) from the table was found to be at 90 min and the lowest mean value (2.63×10^6 cfu/ml) was at 120 mins osmotic process duration. Higher mean value of bacteria load was obtained at 40°C osmotic solution temperature and it was also observed that bacteria load decreased as the temperature increased. The product might have absorbed some moisture while in storage thereby increasing the water activity which in turn might have increased the bacteria load. [15] reported that free water or available water as responsible factor for growth of moulds, yeast and bacteria.

Table 2

Duncan's New Multiple Range Test (DNMRT) for the effect of process conditions on bacteria load

Osmotic Process Duration, min	60	90	120	150
Bacteria Load, 10^6 cfu/ml	2.93 ^c	3.71 ^a	2.63 ^c	3.18 ^b
Osmotic Solution Concentration, %(w/w)	5	10	15	20
Bacteria Load, 10^6 cfu/ml	3.09 ^a	2.85 ^b	3.42 ^b	3.09 ^a
Osmotic Solution Temperature, °C	30	40	50	60
Bacteria Load, 10^6 cfu/ml	3.22 ^a	3.34 ^a	2.95 ^b	2.95 ^b

Means with the same alphabet are not significantly different from each other at $p \leq 5\%$

Effect of osmotic process duration, osmotic solution concentration and osmotic solution temperature on vitamin C. Figure 2 shows the effect of osmotic process conditions on vitamin C. The highest amount of vitamin C (63.43mg/100g) was at 40°C osmotic solution temperature, 15%w/w of osmotic solution concentration and at 120 min osmotic process duration while the lowest amount of vitamin C (51.23mg/100g) was found to be at 60°C osmotic solution temperature, 15% w/w osmotic solution concentration and 150 minutes osmotic solution temperature. This observation is in line with what was reported by [16] that exposure to temperature via cooking would not favour vitamin C. Also, [17] reported that there is tendency for vitamin C to degrade steadily during prolonged storage. The fairly high value of the control sample (59.88mg/100g) could mean that the process conditions were not harsh enough to cause a sharp drop in vitamin C.

The effect of individual process conditions on Vitamin C is shown in Table 3. The highest mean value of Vitamin C (58.88mg/100g) was obtained at osmotic solution temperature 30°C and it was observed that Vitamin C decreased as temperature increased. It was seen that there was an increase in the amount of Vitamin C as osmotic process duration increased from 60 minutes to 150 minutes. There was retention in the amount of Vitamin C which agreed with what [18] reported that osmotic dehydration was a means of enhancing the processing of tropical fruits and vegetables with retention of initial fruit and vegetables characteristics in terms of colour, aroma and nutritional compounds.

Effect of osmotic process duration, osmotic solution concentration and osmotic solution temperature on vitamin A. As seen in figure 3, there was a general increase in the amount of vitamin A as osmotic solution temperature increased from 30°C to 60°C. However, the highest amount of Vitamin A (0.73mg/100g) was at 60°C osmotic solution temperature, 5%w/w osmotic solution concentration and 60 min osmotic process duration. The irregularities in the amount of Vitamin A present may be as a result of variables like maturity, variety, pretreatments, temperature, nature and concentration of osmotic agent, geometry of the material, fruit pieces to osmotic solution ratio, physico-chemical properties, additives, structure, pressure as reported by [5].

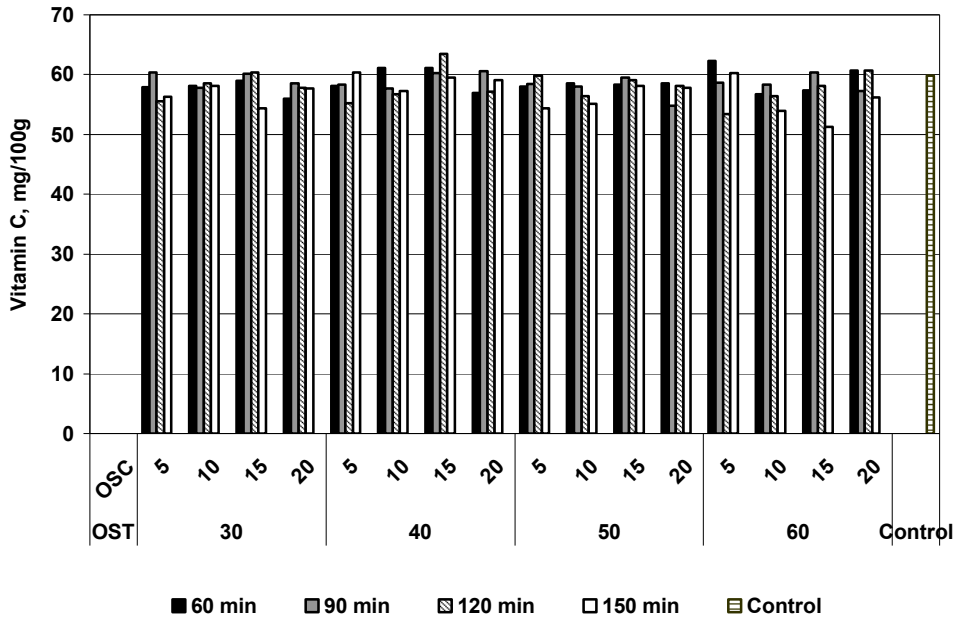

Figure 2. Effect of osmotic process condition, osmotic solution temperature and osmotic solution concentration on vitamin C

Table 3
Duncan's New Multiple Range Test (DNMRT) for the effect of process conditions on vitamin C

Osmotic Process Duration, min	60	90	120	150
Vitamin C, mg/100g	57.51 ^c	58.07 ^b	58.19 ^b	58.31 ^a
Osmotic Solution Concentration, %(w/w)	5	10	15	20
Vitamin C, mg/100g	57.99 ^b	57.54 ^b	58.52 ^a	58.03 ^a
Osmotic Solution Temperature, °C	30	40	50	60
Vitamin C, mg/100g	58.88 ^a	58.61 ^a	57.89 ^b	56.69 ^c

Means with the same alphabet are not significantly different from each other at $p \leq 5\%$

The individual effect of the process conditions on Vitamin A is shown in the Table 4 below. The table shows that the highest mean value of Vitamin A (0.68mg/100g) was at 30°C osmotic solution temperature and it was noticed that the amount of Vitamin A reduced as osmotic solution temperature increased from 30°C to 60°C. The lowest mean value of Vitamin A (0.65mg/100g) is at osmotic solution temperature 60°C. This could be as a result of process temperatures during pre-treatment and final drying operations which could have caused the Vitamin A content to further reduce over the storage period.

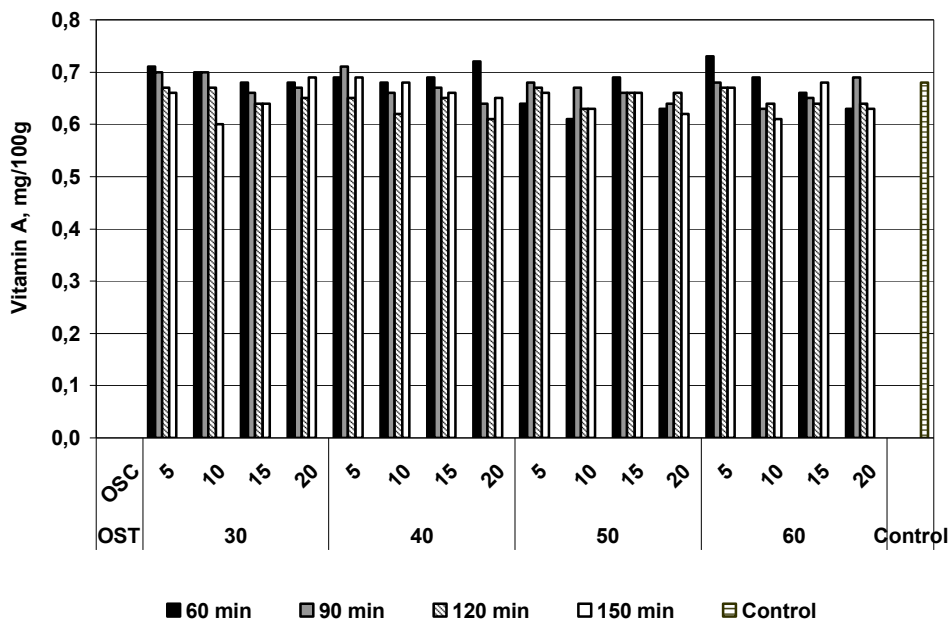

Figure 3. Effect of osmotic process duration, osmotic solution temperature and osmotic solution concentration on Vitamin A

Table 4
Duncan's New Multiple Range Test (DNMRT) for the effect of process conditions on vitamin A

Osmotic Process Duration, min	60	90	120	150
Vitamin A, mg/100g	0.66 ^b	0.67 ^a	0.67 ^a	0.66 ^b
Osmotic Solution Concentration, %(w/w)	5	10	15	20
Vitamin A, mg/100g	0.68 ^a	0.65 ^c	0.66 ^b	0.65 ^c
Osmotic Solution Temperature, °C	30	40	50	60
Vitamin A, mg/100g	0.68 ^a	0.66 ^b	0.65 ^b	0.65 ^c

Means with the same alphabet are not significantly different from each other at $P \leq 5\%$

Effect of osmotic process duration, osmotic solution concentration and osmotic solution temperature on sensory quality (colour). Figure 4 shows the effect of the process conditions on sensory quality. From the figure, the highest color value, 31.83 (DY (deep yellow)) was noticed at osmotic solution temperature 50°C, osmotic solution concentration 20 % w/w and osmotic process duration 120 min. It was also clearly noticed that the control (untreated) samples had the least color value (23.82) denoted as B (brown). This observation is a confirmation of what [5] said that osmotic dehydration is a process that used to increase the sensory qualities (e.g. colour and flavour) of products.

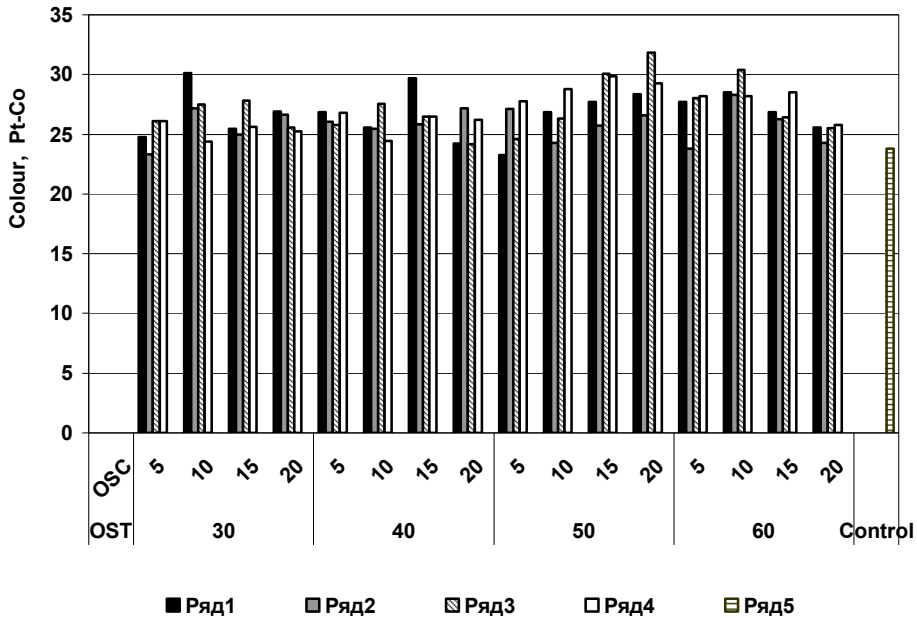

Figure 4. Effect of osmotic process duration, osmotic solution temperature and osmotic solution concentration on colour

T- test result. The T-test for the amount of vitamin C was calculated to be 55.71 while that of vitamin A was calculated to be 161.23. From the T-test table [12], at degree of freedom (df) 63 and level of significance (α) 5%, the table value (critical value) of vitamin C was gotten to be 1.99 while the table value (critical value) of vitamin A was found to be about 1.96. From the aforementioned, the calculated values for both vitamin C and vitamin A were greater than their table values hence, H_0 (null hypothesis) was rejected and H_1 (alternative or research hypothesis) was accepted. This means there is a significant difference in the amount of vitamin C and vitamin A present in the pretreated dried red bell pepper before storage and the amount after storage. This could be as a result of environmental conditions of the storage medium like temperature and relative humidity, maturity level of samples before pre-treatment, side effect of handling during the experiment or ageing of samples in storage. All these observations were in line with what was reported by [17] that vitamins have the tendency of steadily degrading during prolonged storage. The percentage drop in the amount of vitamin C and vitamin A of pretreated dried red bell pepper before and after storage was 53.40% and 53.10% respectively

Regression equations. Equations 4 – 7 present the regression equations developed for vitamin C (VIT C), vitamin A (VIT A), Bacteria Load (BL) and Colour (COL) with respect to the input factors: A(Osmotic Process Duration)), B(Osmotic Solution Concentration) and C(Osmotic Solution Temperature).

$$\text{VIT C} = 60.141 + 0.130A + 0.560B - 0.374C, \text{ P-value} = 0.006, R^2 = 0.60 \quad (4)$$

$$\text{VIT A} = 415.462 - 3.770A - 7.542B + 3.769C, \text{ P-value} = 0.005, R^2 = 0.55 \quad (5)$$

$$\text{BL} = 3.637 - 0.001A + 0.012B - 0.012C, \text{ P-value} = 0.007, R^2 = 0.66 \quad (6)$$

$$\text{COL} = 24.032 - 0.001A + 0.030B + 0.049C, \text{ P-value} = 0.003, R^2 = 0.88 \quad (7)$$

It was observed from equations 4 to 7 that the P-values for the equations developed were low. The low P-values (less than 0.05) is one of the possibilities that all the regression equations developed would suitably explain the characteristics of the pre-treated dried red bell pepper after storage. R^2 value is the coefficient of multiple determination and it is a measure of the amount of reduction in variability of outputs (vitamin A, vitamin C, colour and bacteria load) obtained by using the variables(inputs), that is, osmotic process duration (A), osmotic solution temperature (C) and osmotic solution concentration (B). Some of the equations developed did not have high R^2 values but according to [19], a large value of R^2 does not necessarily implied that a regression model is a good one and a low R^2 value does not mean that the equation is a bad one. Also, R^2 is an index that explains the strength of linear relationship between input and output variables. The not too high R^2 values(except for colour) obtained for some of the regression equations developed showed that there was no strong linear relationship between the input variables (A, B and C) and output variables (vitamin A, vitamin C, colour and bacteria load) of the pre-treated dried red bell pepper after storage. To further check the suitability of all developed regression equations, the difference between predicted and observed outputs was done.

The summary of the difference between predicted and observed values of the outputs is presented Table 5. The table shows that vitamin C, bacteria and colour predicted well as the difference between the observed and predicted were not much. However, vitamin A did not predict well even though it has low P-value because one of the differences between observed and predicted values vitamin A gave an extremely high value of 37.72 mg/100g.

Table 5
Summary of difference between predicted and observed values of vitamin C and vitamin A

Vitamin C(mg/100g)			Vitamin A(mg/100g)		
Observed A	Predicted B	B-A	Observed A	Predicted B	B-A
57.90	59.52	1.62	0.70	0.71	0.01
59.53	58.58	-0.95	0.69	0.69	0.00
59.50	61.38	1.88	0.65	0.70	0.05
57.27	58.74	1.47	0.64	0.68	0.04
53.95	55.00	-1.05	0.70	38.4	37.72
Bacteria Load (10^6 cfu/ml)			Colour		
Observed A	Predicted B	B-A	Observed A	Predicted B	B-A
2.47	3.34	0.87	24.74	25.59	0.85
2.87	3.40	0.53	25.47	25.89	0.42
2.70	3.22	0.52	24.96	25.86	0.93
2.37	3.28	0.91	25.61	25.80	0.19
2.83	3.16	0.33	25.56	26.23	0.67

Conclusions and recommendations

From this study, it can be concluded that all the process conditions (osmotic solution temperature, osmotic solution concentration and osmotic process duration) had significant effect on the nutritional qualities (vitamins A and C) and bacteria load of stored pre-treated dried red bell pepper but not on sensory quality (colour) at $p \leq 5\%$. The percentage drop in the amount of vitamin C and vitamin A of pre-treated dried red bell pepper before and after storage was 53.40% and 53.10% respectively. Osmotic dehydration pre-treatment retained the sensory quality of red bell pepper. The pre-treated sample had deep yellow colour (DY) which is the closest to red colour (the colour fresh sample) and the control samples (untreated) had a B (brown) colour. The pre-treated dried samples were microbiologically safe for consumption because the highest bacteria load count attained (6×10^6 cfu/ml) was within permissible level required by standard which was given by [14] to be 10^8 cfu/ml of aerobic psychotropic bacteria and 10^7 cfu/ml for lactic acid bacteria as the limiting criteria for ready-to-eat vegetables. The regression equations developed can be used to predict vitamin C, bacteria and colour.

Confirmatory test should be done on the stored products in order to know the specific bacteria that infested the product in storage. Toxicology test should be carried out on the stored products in order to further ascertain their suitability for human consumption. Further validation operation should be carried out on the regression equations developed especially for vitamin A and optimization of the post storage qualities should be done.

References

1. George Metaljan Foundation (GMF) (2014), *Bell Peppers - The world healthiest food*, Available at: whfoods.org, Retrieved 1/12/ 2014.
2. Available at: www.fruitsinfo.com, Date accessed: 15/14/2013.
3. Vengaiah P.C. and Pandey, J.P. (2006), *Dehydration Kinetics of Sweet Pepper (Capsicum annuum L.)*, Available at: www.aseanfoodinfo/Articles/11018495.pdf, Date accessed: 15/4/2013.
4. Ebru E and Yildiz H. (2010), Recent Developments in Osmotic Dehydration. *Academic Food Journal*, 8(6), pp. 24-28.
5. Chavan U. D and Amarowicz R. (2012), Osmotic Dehydration Process for Preservation of Fruits and Vegetables. *Journal of Food Research*, 1(2), pp. 202-210.
6. Lucia M. D and Assenato D. (1994), *Agricultural engineering in development*. Rome, Viale delle Terme di Caracalla, Italy: Food and Agriculture Organization of the United Nations. Retrieved December 12, 2014, Available at: <http://www.fao.org/docrep/t0522e/T0522E00.htm#Contents>.
7. FAO (2005), *Handling and Preservation of fruits and vegetables by combined methods for rural areas*, *Agricultural Service Bulletin*, 149, pp. 39-53.
8. Odewole M. M. (2014), *Effect of Osmotic Dehydration Pretreatments on Drying Rate and Quality of Red Bell Pepper*. M.Eng. Research Project, Department of Agricultural and Biosystems Engineering. Faculty of Engineering and Technology, University of Ilorin, Ilorin, Kwara State, Nigeria.
9. Omodara M. A. (2011), *Effects of some Drying Parameters on the Drying Rate and Quality of African cat fish*. M. Eng. Thesis, University of Ilorin, Ilorin, Nigeria.

10. AOAC (1990), *Official Methods of Analysis*. 15th ed, Association of Official Analytical Chemists, Washington, DC, USA.
11. Fawole, M. O and Oso, B.A. (2001), *Laboratory Manual of Microbiology*, Spectrum Books Limited, Ilorin, pp.74-75.
12. Oyejola B.A and Adebayo S.B. (2004), *Basic Statistics for Biology and Agriculture Students*, OLAD Publishers, Ilorin, Nigeria, pp. 103-112.
13. Mossel D., Corry J and Struijk C. B. (1995), *Essentials of the Microbiology of Foods: a Textbook for Advanced Studies*, John Wiley and Sons, Chichester.
14. Debevere J. (1996), *Criteria and practical methods for determining shelf life. Labelling, Shelf life and Storage*, Die Keure, Brugge, pp. 37-67.
15. Sandulachi E. (2012), *Water Activity Concept and its role in Food Preservation*, Technical University of Moldova, pp. 40-48.
16. Njoku P.C., Ayuk A.A and Okoye C.V. (2011), Temperature Effects on Vitamin C Contents in Citrus Fruits, *Pakistan Journal of Nutrition*, 10(12), pp. 1168-1169.
17. Murcia, M. A., Opez-Ayerra, B.L., Martinez-Tom, A.M and Vera, A.M. (2000), Industrial processing of broccoli in fruits, *Sci. Food Agric.*, 80, pp. 1882-1886.
18. Pokharkar, S. M and Prasad, S. (1998), Mass Transfer during osmotic dehydration of banana slices. *J. Food Sci. Technol*, 35(4), pp 336-338.
19. Montgomery, D. C., Runger, G.C and Hubele, N.F. (1998), *Engineering Statistics*, John Wiley and Sons, New York, pp.322-324.

Identification and characterization of bacterial and fungal isolates in raw milk samples from different breeds

Musliu Olushola Sunmonu, Michael Mayokun Odewole,
Aliu Olamide Oyedun, Hafsat Funmilayo Bankolen

University of Ilorin, Faculty of Engineering and Technology, Department of Food
and Bioprocess Engineering, Ilorin, Nigeria.

Abstract

Keywords:

Bacillus
Penicillium
Lactis
Lactobacillus
Aspergillus

Article history:

Received 27.09.2015
Received in revised
form 11.12.2015
Accepted 24.12.2015

Corresponding author:

Musliu Olushola
Sunmonu
E-mail:
sholams2000@
yahoo.co.uk

Introduction. This study was conducted to identify and name the fungal and bacterial isolates in raw milk samples from different breeds.

Materials and methods. Milk samples were collected from White Fulani breed, New Jersey breed and the breed mixture (White Fulani and New Jersey breed). The samples were further grouped into four and were pasteurized at 71°C for 15seconds, 66°C for 15minutes and 61°C for 30minutes using pasteurizer made of aluminium, stainless steel and galvanized steel

Results and discussion. The raw samples were also identified and characterized for bacterial and fungal isolates; *Staphylococcus aureus*, *Bacillus subtilis*, *Euterobacter aerogenes*, *Escheria coli*, *Streptococcuss lactis*, *Proteus vulgaris*, *Pseudomonas aeruginose*, *Serratia marcescens*, and *Lactobacillus ferment* for bacterial isolates and *Aspergillus flavus*, *Aspergillus niger*, *Penicillium citrinium*, *Sacchanomyces Cerevisiae*, *Paecilomyces Varioti*, *Penicillium Chrysogenum* for fugal isolates. *Staphylococcus aureus* can be seen to be 78.79% present in the total samples before and after pasteurization. *S. auereus* was seen in the raw samples i.e. the White Fulani breed, New Jersey breed, the breed mixture and the locally fermented samples (nono), making them highest. The following percentage shows the distribution of the other bacterial present; *B. subtilis* (6.06%), *E. aerogenes* (42.42%), *E coli* (3.03%), *S. lactis* (48.48%), *P. vulgaris* (18.18%), *P. aeruginosa* (30.30%), *S.marcescens* (33.33%), *L. fermentum* (30.30%). Furthermore, the percentage distribution of the fungi present from table 4.4 are; *A. flavis* (54%), *A. niger* (18.18%), *P. citrinum* (21.21%), *S. cerevisiae* (57.58%), *P. varioti* (15.15%), *P. chrysogenum* (6.06%). The best treatment combination within the scope of this research work in order to get low bacterial counts is pasteurizing at 71°C using stainless steel for 15seconds, indicating high temperature short time pasteurization. Also, in order to get low fungi counts, the temperature of 61°C should be used for pasteurizing using a stainless steel for 30minutes.

Conclusion. Nine bacterial isolates and six fungi isolates were identified and characterized in raw milk samples from the different breeds

Introduction

Measurement of bacterial numbers in milk is of interest because they are indicator of poor milk hygiene production or ineffective pasteurization of milk. Some microbes such as gram negative Psychrotrophs, Coliforms and other pathogenic bacteria such as *Escherichia Coli*, *Staphylococcus aureus* may also be found in milk.

The hygienic quality of milk at the point of production is also of importance from both public health and consumer perception points of view. For milk to be produced with a low bacterial count the temperature must be kept low until the point of processing. The milk is contaminated after pasteurization, usually through unsanitary handling of the milk. An example of post-pasteurization contamination involving a multi-drug resistant strain of *Salmonella Typhimurium* occurred in Pennsylvania and New Jersey in 2000 [1]

The microorganisms which cause spoilage in milk, which is intended to be sterilized (UHT-treatment) are either resistant types that have survived the heat treatment, or organisms that have contaminated the product after the sterilization process. Contamination spores are however, likely to be less heat resistant than those which might survive the heat treatment. The pasteurization equipment fails and there is raw milk in the product sold as pasteurized. This can happen if the temperature is not high enough, or if the milk is not heated long enough. For example, in 1984, an outbreak of *Salmonella Typhimurium* occurred in a convent in western Kentucky [2].

There were 16 illnesses and one patient developed a Guillain-Barretype illness. The convent had a steam pasteurizer and investigators believe that the temperature may not have been high enough and/or the holding time was too short. The convent had no time-temperature gauge to record and monitor the process. The milk is contaminated after pasteurization, usually through unsanitary handling of the milk. An example of post-pasteurization contamination involving a multi-drug resistant strain of *Salmonella Typhimurium* occurred in Pennsylvania and New Jersey in 2000 [1]

UHT treatment of milk leads to a much larger production of small sized casein micelles compared to raw or pasteurized milk [3].

Biochemical processes involved are “heat resistance” and reactivation of natural and bacterial proteases and survival of bacterial spores [3]; [4].

Proteolysis of UHT milk during storage at room temperature is a major factor limiting the shelf life through changes in its flavor and texture [5].

The problem of post treatment contamination of “in container” sterilized product can either be through “poor seal” or through “pin hole” in the container. Post treatment contaminants in UHT milk may be either by spores which would not be expected to be heat resistant enough to survive the heat treatment or non-heat resistance vegetative organisms. Organisms of the first type will probably have entered from the ineffective sterilization of plant downstream from the heat treatment stage of the process, which includes spores of *Bacillus cereus* [6] and [7]. Organisms of second type will probably have entered through poorly sealed container after aseptic filling. The types of spores, which have been investigated as of particular relevance in the UHT, are those of *Bacillus Stearothermophilus*, *Bacillus Subtilis* and *Clostridium Botulinum* has been studied. The high spore counts can occur at the dairy farm and that feed and milking equipment can act as reservoirs or entry points for potentially highly heat resistant spores into raw milk. Lowering this spore load by good hygienic measures could probably further reduce the contamination level of raw milk, in this way minimizing the aerobic spore forming bacteria that could lead to spoilage of milk and dairy products[8]

The purpose of this work is to identify and characterize the bacterial and fungal isolates in raw milk samples from different breeds

Objectives of research:

-to determine the pasteurizing temperature and time that will favour low fungal and bacterial counts in raw milk samples

-to determine the pasteurizing materials that will favour low fungal and bacterial counts

Materials and methods

The various material and devices used in this work and the basis of their selection as well as some of their standard properties are discussed as follow:

Aluminium Pot. This is one of the material used to hold milk during pasteurization. The basis for its selection is not unconnected to some of its fundamental properties that are relevant to this research work. Aside its properties, it is selected due to its availability. It is readily available in different capacities. In terms of its properties, aluminium is highly resistant to corrosion and has a thermal conductivity “k” of 99.99% for pure aluminium is 244 W/mK for the temperature range 0-100⁰C. Since this work is based on heat treatment, use of material that can easily transfer heat is necessary. Milk is also made up of 95% water in its composition hence the need to select a material that effectively resists corrosion. Other properties of aluminium that are of interest include: density of 2700kg/m³, and approximate specific heat capacity of 900 J/kgK [9].

Stainless steel pot. This is another material used as a medium for holding milk during the pasteurization process. It is also readily available. Its selection was based on its high corrosion resistance capability, good thermal conductivity (average of 15w/m⁰C for all grades). It has a specific heat capacity of 500J/kgK on the average and a density of about 8.03kg/m³.

Galvanized Steel Pot. Steel on its own is corrosive when in contact with water. Due to the high water content of milk, the galvanized steel pot is coated with Zinc-Aluminium alloy to prevent reaction of the milk with the steel. Steel has a thermal conductivity of 58.9W/mK, specific heat capacity of 420J/kgK and a density of 7900kg/m³.

Heating Medium. An electric stove with an AC voltage of 220V, a frequency of 50/60Hz and a thermal coil element rating of 1000w was selected for heating the milk at regulated temperatures. The cost of the stove is relatively cheap and it is available and can provide the desired power rating required.

K-type Thermocouple. The thermocouple is a sensor attached to the material and connected to a temperature regulator. It senses the temperature of the milk and conveys this information to the regulator which then adjusts the temperature if necessary to a predetermined set point. The K-type (Chromel - Alumel) was selected because of its unlike other types of thermocouples (B, C, E, J, N, R, S, T types), it is well suited for oxidizing atmospheres; that is, it resists corrosion and has a useable temperature range of 95⁰C to 1260⁰C. It has a good degree of sensitivity of 39μV/⁰C, durable and readily available [10].

Temperature Controller. The temperature controller is a device used to maintain the desired temperature for the different pasteurization treatments of the milk. It was selected because of the need to maintain the different temperatures for specific periods. It works on the principles of a temperature control loop. The sensor (k-type thermocouples) measures the temperature of the milk to be controlled and converts the measured value into a travel

signal. The information is received by the regulator and compared to the set point (pasteurizing temperature) and make adjustment when necessary.

Preparation of culture Media. The media to be used for this analysis are Nutrient Agar (NA) for total bacteria, Mac Conkey agar for enumeration of coliform bacteria, Eosin Methylene Blue agar for fecal coliform enumeration, Demann Rogossa Sharpe agar for enumeration of lactobacillus, Yeast Extraction agar for enumeration of yeast and Potato Dextrose Agar (PDA) for enumeration of fungi. count. The said culture media were prepared in line with the manufacturer’s instruction. The colonies were counted and associated microorganisms were isolated, characterized and identified according to the techniques described by [11] in the laboratory manual of microbiology.

Results and discussion

Identification and Characterization of Bacterial Isolates. Table 4.1 and 4.2 showed the identification and characterization of bacterial and fungal isolates from raw milk samples respectively.

Table 1
Table showing the identification and characterization of bacterial isolates

Isolates	1	2	3	4	5	6	7
Gram reaction	+	+	-		+	-	-
Catalase	+	+	+	+	+	+	+
Mobility Test	+	+	+	+	+	+	+
Methyl red Test	-	+	+	+	-	+	-
Voges Preskauer Test	-	+	+	+	-	-	-
Oxygen relationship	FA	FA	FA	FA	FA	AE	FA
Indole Test	+	-	-	+	-	+	-
Urease Test	-	-	-		-	+	+
Citrate Utilization Test	-	+	-	-	-	-	+
Coagulase Test	+	-	-	-	-	-	-
Oxidase Test	-	-	-	-	-	-	-
Starch Hydrolysis Test	+	+	-	-	+	-	-
Hydrogen sulphide test	-	-	-	-	-	+	-
Glucose	AG	A	AG	A	A	AG	-
Sucrose	A	A	AG	AG	A	AG	-
Lactose	A	A	AG	AG	A	-	-
Maltose	A	A	AG	AG	A	-	-
Fructose	A	A	AG	AG	A	-	-
Probable Organism	<i>Staphylococcus aureus</i>	<i>Bacillus subtilis</i>	<i>Euterobacter aerogenes</i>	<i>Escherichia coli</i>	<i>Streptococcus lactis</i>	<i>Proteus vulgaris</i>	<i>Pseudomonas Aeruginose</i>

+ = Positive, AE= Aerobic, - = Negative, FA = Facultative Anaerobic, A= Acid Production, AG =Acid and Gas Production

Table 2

Table showing the fungal isolated from milk samples

	Surface Texture	Pigmentation	Under Surface	Tentative identification
AL _A	Powdery	Greenish yellow	Creamy	<i>Aspergillus flavus</i>
AL _B	Powdery	Black	Creamy	<i>Aspergillus niger</i>
AL _C	Powdery	Greenish Blue with Narrow margin	Creamy	<i>Penicillium citrinum</i>
AL _D	Smooth	Creamy	Creamy	<i>Saccharomyces Cerevisae</i>
AL _E	Powdery	White	Creamy	<i>Paecilomyces Varioti</i>
AL _F	Powdery	Greenish Blue with Wide margin	Creamy	<i>Penicillium Chrysogenum</i>

+ = Positive, AE= Aerobic, - = Negative, FA = Facultative Anaerobic, A= Acid Production, AG =Acid and Gas Production

As shown in the table 4.1 and 4.2, the samples were subjected to gram reaction, catalase test, mobility test, methyl red test, voges presk auer test, oxygen relationship test, indole test, urease test, citrate utilization test, coagulase test, oxidase test, starch hydrolysis test, hydrogen sulphide test. Also, sugar fermentation test for glucose, sucrose, lactose maltose and fructose as well as the various identification and characterization of bacterial and fungi isolates were done on the samples according to the technique described by [11]. Organisms like *Staphylococcus aureus*, *Bacillus subtilis*, *Escherichia coli*, *Streptococcus lactis*, *Proteus vulgaris*, *Pseudomonas aeruginosa*, *Serratia marcescens*, *Lactobacillus fermentum* and *Enterobacter aerogenes* were present as bacterial. Furthermore, organisms like *Aspergillus flavus*, *Aspergillus niger*, *Penicillium citrinum*, *Saccharomyces cerevisiae*, *Paecilomyces varioti* and *Penicillium chrysogenum* were identified and characterized as fungi specie.

Distribution of bacterial species in the pasteurized milk samples. Table 3 and 4 showed the distribution of bacterial species and fungal species respectively in the milk samples.

Table 3

Table showing the distribution of bacterial species in the pasteurized milk samples

Sample Code	Bacterial species								
	<i>Staphylococcus aureus</i>	<i>Bacillus subtilis</i>	<i>Enterobacter aerogenes</i>	<i>Escherichia coli</i>	<i>Streptococcus lactis</i>	<i>Proteus vulgaris</i>	<i>Pseudomonas aeruginosa</i>	<i>Serratia marcescens</i>	<i>Lactobacillus fermentum</i>
M1T1S1	+	-	-	-	-	+	-	+	-
M1T1S2	+	-	-	-	+	-	-	-	-
M1T1S3	+	-	-	-	+	-	-	+	-
M1T2S1	+	-	+	-	+	-	-	+	-
M1T2S2	+	-	-	-	+	-	+	-	-
M1T2S3	-	-	-	-	+	-	-	-	+
M1T3S1	-	-	+	+	-	-	+	+	-
M1T3S2	+	-	-	-	+	-	+	-	-
M1T3S3	+	-	-	-	-	-	+	-	-
M2T1S1	-	-	-	-	-	+	-	+	-
M2T1S2	+	-	+	-	-	+	-	-	-
M2T1S3	+	-	-	-	+	-	-	-	-
M2T2S1	-	-	-	-	-	+	-	+	+
M3T2S2	+	-	-	-	+	-	-	-	+
M2T2S3	+	-	+	-	-	-	-	-	+
M2T3S1	-	+	-	-	-	-	-	-	-
M2T3S2	+	-	-	-	-	-	-	-	-
M2T3S3	+	-	-	-	-	-	-	+	+
M3T1S1	+	-	+	-	+	-	+	-	-
M3T1S2	+	-	+	-	-	-	-	-	+
M3T1S3	+	-	+	-	-	-	-	-	-
M3T2S1	-	-	+	-	+	-	-	+	-
M3T2S2	+	-	-	-	-	-	-	+	-
M3T2S3	+	-	+	-	+	+	+	-	-
M3T3S1	-	-	+	-	-	-	-	-	+
M3T3S2	+	-	+	-	+	-	-	-	-
M3T3S3	+	-	-	-	-	+	-	+	+
RAW S1	+	-	+	-	+	-	-	-	-
RAW S2	+	+	-	-	+	-	+	-	-
RAW S3	+	-	-	-	+	-	+	+	-
FM S1	+	-	+	-	-	-	+	-	+
FM S2	+	-	+	-	+	-	-	-	+
FM S3	+	-	-	-	-	-	+	-	-

(+)= Present, (-)=Negative

Table 4

Table showing the distribution of fungal species in the pasteurized milk samples

Sample Code	Fungi species					
	<i>Aspergillus flavus</i>	<i>Aspergillus niger</i>	<i>Penicillium citrinum</i>	<i>Saccharomyces cerevisiae</i>	<i>Paecilomyces varioti</i>	<i>Penicillium chrysogenum</i>
M1T1S1	+	-	+	-	-	-
M1T1S2	-	-	-	+	-	-
M1T1S3	+	-	-	-	-	-
M1T2S1	+	-	+	-	-	-
M1T2S2	-	-	-	+	-	-
M1T2S3	+	+	-	-	-	-
M1T3S1	+	+	+	-	-	-
M1T3S2	-	-	-	+	-	-
M1T3S3	+	-	-	-	-	-
M2T1S1	-	-	-	+	-	+
M2T1S2	+	-	-	+	-	-
M2T1S3	-	+	-	-	-	-
M2T2S1	+	-	+	-	-	-
M3T2S2	+	+	-	+	+	-
M2T2S3	+	-	-	+	-	-
M2T3S1	+	-	+	-	-	-
M2T3S2	+	-	-	-	+	-
M2T3S3	-	-	-	-	+	-
M3T1S1	-	-	-	+	-	-
M3T1S2	-	-	-	-	+	-
M3T1S3	+	-	+	+	-	-
M3T2S1	+	-	-	-	-	+
M3T2S2	+	+	-	-	-	-
M3T2S3	-	+	-	+	-	-
M3T3S1	+	-	-	+	-	-
M3T3S2	+	-	-	+	-	-
M3T3S3	+	-	+	+	-	-
RAW S1	-	-	-	+	+	-
RAW S2	-	-	-	+	-	-
RAW S3	-	-	-	+	-	-
FM S1	-	-	-	+	-	-
FM S2	-	-	-	+	-	-
FM S3	-	-	-	+	-	-

(+)= Present, (-)= Negative

M=Materials (M1 = Aluminium, M2= Stainless steel, M3=Galvanized Steel), T=Temperature (T1=71°C, T2=66°C, T3=61°C) and S=Source (S1=White Fulani, S2= New Jersey, S3=Mixture), MT=Material and and Temperature Combination, MS=Material and Source Combination, TS=Temperature and Source Combination, MTS=Material, Temperature and Source Combination, TVC=Total Viable Counts, CC=Coliform Counts, FCC=Faecal Counts, LBC=Lactobacillus Counts, FC=Fungi Counts, df=Degree of Freedom

From table 3, *Staphylococcus aureus* can be seen to be 78.79% present in the total samples before and after pasteurization. *S. aureus* was seen in the raw samples i.e. the White Fulani breed, New Jersey breed, the breed mixture and the locally fermented samples (nono), making them highest. The following percentage shows the distribution of the other bacterial present; *B. subtilis* (6.06%), *E. aerogenes* (42.42%), *E. coli* (3.03%), *S. lactis* (48.48%), *P. vulgaris* (18.18%), *P. aeruginosa* (30.30%), *S. marcescens* (33.33%), *L. fermentum* (30.30%). Furthermore, the percentage distribution of the fungi present from table 4.4 are; *A. flavis* (54%), *A. niger* (18.18%), *P. citrinum* (21.21%), *S. cerevisiae* (57.58%), *P. varioti* (15.15%), *P. chrysogenum* (6.06%)

The presence of these large number of microflora suggests the extent to which the milk is contaminated by the animal, environment and the milking utensils [12]. The Fulani herdsmen do not disinfect the teats and udders prior to milking despite the fact that the cow lie in muddy barnyard and dirty environment which inevitably contaminate the milk and increase the microbial load [16]. [13] reported that organism associated with the beddings materials which contaminate the surface of teats and udders includes Staphylococci, Spore formers, coliforms, Streptococci and other Gram negative bacteria. The sampled raw milk has high microbial load probably due to the insanitary condition of the environment or post pasteurization contamination.

During this research, *E. coli* was found to be minimal indicating a very low fecal contamination showing a good milk hygiene. Coliform counts between 100 and 1000 are generally an indication of poor milking hygiene as the coli count less than 100 per ml of milk is considered acceptable for raw milk for pasteurization [14]. [15] also reported bacterial and fungi isolated from raw milk and pasteurized milk samples in his research done in Ilorin and its surroundings, in Kwara state, Nigeria. These isolates are similar to the isolates in this research work.

Conclusions

This study focused on the identification and characterization of bacterial and fungi isolates in raw milk samples from different breeds. It can be concluded that organisms like *Staphylococcus aureus*, *Bacillus subtilis*, *Escherichia coli*, *Streptococcus lactis*, *Proteus vulgaris*, *Pseudomonas aeruginosa*, *Serratia marcescens*, *Lactobacillus fermentum* and *Enterobacter aerogenes* were present as bacterial. Furthermore, organisms like *Aspergillus flavus*, *Aspergillus niger*, *Penicillium citrinum*, *Saccharomyces cerevisiae*, *Paecilomyces varioti* and *Penicillium chrysogenum* were identified and characterized as fungi specie.

References

1. Olsen S. J., Ying M., Davis M. F., Deasy M., Holland B., Iampietro L., Baysinger C. M., Sassano F., Polk L. D., Gormley B., Hung M. J., Pilot K., Orsini M., Van Duyn S., Rankin S., Genese C., Bresnitz J., Smucker M. Moll and Sobel J. (2004), Multidrug-resistant *Salmonella Typhimurium* infection from milk contaminated after pasteurization, *Emerg Infect Dis*, 10, pp. 932-935.
2. CDC (1984), *Salmonellosis from inadequately pasteurized milk--Kentucky*. *MMWR Morb Mortal Wkly Rep*, 33, pp. 505-506.
3. Singh H.S. (1993), Heat induced interactions of proteins in milk, *Protein and fat globule Modifications, IDF seminar*, Special Issue 9303.1

4. Manji B., Khakuda K (1988), The role of protein denaturation, extent of proteolysis, and storage temperature on the mechanism of agegelation in a model, *J. Dairy Sci.*, 71(6), pp. 194-201.
5. Datta N., Elliot A. J., Perkin M.L., Deeth H.C. (2002), UHT treatment of milk: comparison of direct and indirect methods of heating, *Aus J. Dairy Tech.*, 57(3), pp. 211-257.
6. Davies F.L. (1975), Heat resistance of Bacillus species, *J. of the Soc. of Dairy tech.*, 28, pp. 69-72.
7. Wilson H.K, Herreid E., Whitney R.M. (1960), Ultracentrifugation Studies of Milk Heated to Sterilization Temperatures, *J. Dairy Sci.*, 43, pp. 165-174.
8. Westhoff D.C., Dougerty S.L. (1981), Characterization of bacillus species isolated from spoiled ultrahigh temperature processed milk, *J. Dairy Sci.* 64, pp. 572-577.
9. Cobden R., Alcan Bandury (1994), Aluminium physical properties, characteristics and alloy, 9, 12 & 15.
10. Watlow (2015), Retrieved January 23, 2015, Available at: <http://www.watlow.com/reference/redata/0313.CFM>
11. Fawole M.O., Oso B.A. (2007), *Laboratory manual of Microbiology. 5th edition*, Spectrum Books Ltd, Ibadan.
12. Murphy S.C., Boor K.J. (2000), Trouble shooting sources and causes of high bacteria counts in raw milk, *Dairy Food Environ. Sanitation*, 20(8), pp. 606-611.
13. Bramley A.J. and McKinnon C.H. (1990), The microbiology of raw milk, pp. 163-208. In: *Dairy Microbiology*, Vol. 1., Robinson R.K., Elsevier Science Publishers, London.
14. Douglas J. Reinemann (1997), *Troubleshooting high bacteria counts in farm milk Winsconsin*, University of Florida, Rocky Ridge Veterinary Service.
15. Laba S.A., Udosek C.E. (2013), Bacteriological quality of raw cow milk in Ilorin, north central Nigeria, *Nat. Sci.*, 11(10), pp. 73-79.

Disinfectants efficiency on microorganisms - active gray rot causative agents within the process of sugar beet storage

Natalia Husyatynska¹, Svitlana Teterina¹,
Tetiana Nechipor¹, Irina Kasian²

1 – National University of Food Technologies, Kyiv, Ukraine

2 – Smila Technical School of Food Technologies NUFT, Smila, Ukraine

Abstract

Keywords:

Disinfectant
Micromycete
Slime-forming
Bacteria
Sugar beet

Article history:

Received 20.09.2015
Received in revised
form 11.11.2015
Accepted 24.12.2015

Corresponding author:

Svitlana Teterina
E-mail:
teterina_s@ukr.net

Introduction. The rotting of roots in a heap owing to emergence of microbial processes sometimes is the main cause of loss in beet mass and sucrose, as well as a sharp decline in the quality of raw materials and intermediates.

Materials and methods. The objects of research were selected pure cultures of bacteria of the slime-forming bacteria of *Leuconostoc* genus and mycelial fungi which are active agents for gray rot of sugar beet; roots of selection German hybrid "Oryx"; a new generation of disinfectants.

Results and Discussion. Determination of gray rot causative agents activity carried out at different terms and temperatures of roots storage, previously affected by a certain type of gray rot causative agent. Thus, the fungus *Botrytis cinerea Pers* is a very active gray rot causative agent. Increasing of storage temperature by 15 ... 20 °C promotes the development of Mucorales and the most common types of *Mucor mucedo* and *Rhizopus nigricans*, which in a short time can turn the beet into unprocessable product. The sugar beet samples infected with *Geotrichum candidum* and *Torula beticola*, during storage at a temperature of 0 ... 5 °C for 45 days revealed the presence of external mycelium, but there was almost no development of gray rot causative agent. "Sanitarin", "Javel-Kleyd", "Biodez" and "Hembar" showed the high efficiency on mycelial fungi of different genus. The "Nobak-enzyme" should also be noted which compared to "Nobak" has showed high antimicrobial effect to a wider range of microorganisms. "Betastab" showed high efficacy in slime-forming bacteria, including the *Leuconostoc* genus, at the same time, at these values it is not effective on Micromycetes. Disinfectant "Kamoran" is active on different groups of microorganisms, including Micromycetes and slime-forming bacteria.

Conclusions. The most of the researched means have stable fungicidal and fungistatic effect against a broad spectrum of Micromycetes, these agents are also effective in inhibiting the development of slime-forming bacteria.

Introduction

Improving technological properties and increased resistance of sugar beet to various diseases during growing season and storage is an urgent problem of sugar-beet industry, including complex issues of selection of resistant varieties of beets, compliance with modern agricultural technologies of growing, harvesting and transportation regulations, warehousing and storage technology, the use of fungicidal agents for processing roots that are placed in the heap, and so on. The practice of storing beets indicates that rotting of roots in a heap sometimes is the main cause of loss in beet mass and sucrose, as well as a sharp decline in the quality of raw materials [1, 2, 3, 4, 5, 6, 7].

Ensuring the quality of sugar beet during storage is an important task, because during processing of sugar beets affected by gray rot or mucous bacteriosis, the technological parameters of juices and products are being significantly deteriorated, and there are associated negative consequences - namely, gas formation in the diffusion machine, foaming during saturation, significant difficulties in filtering juices, slow massecuite boiling [1, 8, 9, 10]. As a result of the above-mentioned technological problems sugar plant capacity is reduced, sucrose losses are increased due to decomposition to some organic acids, including through the course of microbiological processes, which leads to a decrease in overall sugar yield and deterioration of its quality.

Having a rotten mass in addition to direct loss of sucrose, leads to a deterioration of a number of technological parameters during beets processing. The results of our research show that in the case of significant microbiological processes, beets become unsuitable for processing, which is also consistent with the findings of other researchers [2, 11, 12, 13, 14].

The emergence of microbiological processes during storage of beet in heaps is caused by long-term storage of root crops in the field after excavation; poor conditions of gray field, entering into heap of the beet with reduced resistance to microbiological lesions (mechanically damaged, immature, affected with microbiological diseases during the growing season, sleepy, frozen), accumulation of large amounts of top within some places of heap, fragments of roots and weeds, which rot in the first place, which promotes gray rot spreading to other root vegetables, etc [6, 12, 15, 16].

Thus, to achieve high economic performance and the production of white sugar, according to DSTU (National Standards of Ukraine), one should pay great attention to ensuring adequate technological quality of sugar beets which enter the processing, including the microbiological contamination of roots. Accordingly, our research objectives was to investigate the effectiveness of a new generation of disinfectants on inhibiting the activity of microorganisms which are active agents for gray rot of sugar beet.

Materials and methods

We found that the contaminating microflora of sugar beet includes a number of Micromycetes of *Fusarium*, *Botrytis*, *Mucor*, *Penicillium*, *Aspergillus*, *Trichotecium*, *Verticillium* genus [17]. In addition, under adverse conditions of roots storage in the heap, active lesions of sugar beet with slimy bacteriosis is possible due to bacteria of the *Leuconostoc* genus, and due to the combined action of ammonifying bacteria *Bacillus subtilis* and *B. megatherium* and others. The research of the effectiveness of these disinfectants was performed on pure museum or isolated cultures of microorganisms from the heaps of Nabutivsky sugar plant.

As for the objects of research, we selected pure cultures of bacteria of the slime-forming bacterias of *Leuconostoc* genus and mycelial fungi of the following genus: *Botrytis*, *Rhizopus*, *Mucor*, *Fusarium*, *Aspergillus*, *Penicillium*, *Geotrichum*, *Gliocladium*, *Torula*.

The research applied the use of roots of selection German hybrid "Oryx", which were grown in a research farm. Indicators of technological quality of the roots amounted to an average of: sucrose content in beet - 16.2 ... 16.4%, purity of beet juice 85,9 ... 86,3%, juice ratio - 93.0 ... 93.4%, root mass 640 ... 750g.

According to modern requirements [2] applicable to disinfectants, the chemicals used as an active substance should be characterized by a wide spectrum of biocidal action and maintain its activity for a long time, should not make a negative impact on the quality of products, as well as belong to class III-IV of moderately hazardous substances under the parameters of acute toxicity. Considering the above factors, the research applied selection of the following disinfectants: based on dichloroisocyanuric acid sodium salt - "Sanitarin", "Javel-Kleyd"; on polyhexamethyleneguanidine (PHMG) - "Biodez", "Hembar"; on cyrocide - "Nobak", "Nobak-enzyme"; monenzine sodium - "Kamoran", natural hydroxy acids - "Betastab."

Selection of active agents. Method of selection of active agents is the study of destructed tissue on the verge of healthy one. To do this, the roots were cut under sterile conditions through the rotted portion, then a small amount of tissue on the verge of healthy and rotten pieces of the root was selected using scalpel and put under sterile conditions into a test tube of Czapek molten medium, beetroot agar, MIA (meat infusion agar). After being stirred, the contents of the tubes were poured into Petri dishes.

According to the methodology, after allocation of mycelial fungi with lesions located on the surface of the root, a part of the external mycelium was selected with thin fried microbiological needle and placed into a test tube with the appropriate nutrient medium. After being stirred, the medium with particles of mycelium and spores was poured into sterile Petri dishes. The cultivation of mycelial fungi in both methods was carried out in thermostats at temperatures of 27 °C and within duration of up to 7 days. From germinated colonies the cultures were inoculated into test tubes with nutrient medium. Pure cultures of fungi were plated on nutrient dense medium for learning morphological characteristics of isolated cultures of microorganisms.

Determination of the activity degree of selected agents. The activity of certain fungi species on gray rot development of sugar beet was determined by means of the following method [18]. For the experiment there were selected unaffected roots of sugar beet of approximately the same size. Roots were preliminary disinfected with a solution of potassium permanganate of pink colour. To make an insert of pure culture of a certain type of Micromycetes there were formed three swath scars on top of each root using a sterile scalpel and the same amount of spore material was inserted into them. For averaging the results of the experiment each type of microorganism had six infected roots. Control experiments were conducted accordingly on the six roots with scars without making spore material.

Within the research there were used both the pure cultures of microorganisms and bacterial cultures and their associative group, isolated with rotten roots.

Infected according to the above method roots were placed in a moist chamber (in desiccators or in sterile plastic bags), where they were kept within 25 ... 45 days at a certain temperature. We used two temperature ranges: 0 ... 5, and 15 ... 20 °C. After the expiration of the retention period the phytopathological survey of roots was conducted. Initially, all the roots were examined externally, to determine the nature of mycelium growth and external picture of destruction, then roots were cut across the scar and the degree of beet tissue rotting was determined.

Determination of the effectiveness of disinfectants activity. To determine the sensitivity of microorganisms to antiseptic preparations, the "holes in the thick agar" method was used. Cultivation of microorganisms was performed on the following nutrient medium:

a - MIA(meat infusion agar) + saccharose and beetroot agar with inclusion of pure culture of *Leuconostoc mesenteroides*;

b - Czapek medium with inclusion of pure cultures of Micromycetes - *Rhizopus nigricans*, *Mucor mucedo*, *Aspergillus niger*, *Penicillium*, *Botrytis cinerea* Pers, *Fusarium culmorum*, *Gliocladium roseum*.

Nutrient medium with corresponding culture of microorganisms were poured into sterile Petri dishes. After solidification of nutrient medium the holes were made within each 1.8 ... 2.2 cm from the edge of the dish, using a sterile drill. The appropriate disinfectant solutions of various concentrations were inserted into the holes.

Conclusions about the effectiveness of disinfectants at a certain solution concentration were made according to the availability of areas of stunted growth of microorganisms. No areas of stunted growth indicates that the studied culture is insensitive to the action of the product at the specified concentration. With the zone diameter of 15 mm we believe that microorganisms have a small degree of sensitivity to the corresponding concentration of the product, with the zone diameter of 15 to 25 mm the average degree of sensitivity is indicated. Availability of the zone with diameter greater than 25 mm indicates a high degree of sensitivity of microorganisms to the concentration of the antimicrobial agent.

Results and discussion

Determination of gray rot causative agents activity. Since the species composition of the microflora of sugar beet is represented by more than 100 types of gray rot causative agents, activity of which depends on a combination of physiological and morphological properties, as well as environmental conditions, it is important to analyze the microflora in sugar beet heaps in order to detect the most active causative agents of gray rot.

Within the research conducted on Nabutivsky sugar plant it was found that the roots selected from the heap were affected by associative group of mycelial fungi, which leads to their rapid rotting. In particular, besides the types of mycelial fungi that were found in the analysis of beets included into the heap, infected roots after storage revealed micromyceta of *Botrytis cinerea*, *Mucor mucedo*, *Rhizopus nigricans*, genera *Penicillium*, *Aspergillus*, *Trichotecium*, *Verticillium*, *Gliocladium*, *Fusarium*, *Trichoderma*, *Torula* and bacteria *Bacillus subtilis*, *Leuconostoc mesenteroides*, *L. Dextranicum* species.

Gray rot development is a complex process due to a number of factors, and is a consequence of life of a wide range of microorganisms, and the degree of root damage is largely dependent on the activity of the gray rot causative agent. So the study of activity of the most active representatives of mycelial fungi on the intensity of gray rot is of scientific and practical interest because usually most of the bacteria have no ability to penetrate the intact surface of plant organisms and are secondary infection after Micromycetes affect [17, 18].

As for an object of research, there were used pure cultures of microorganisms *Botrytis cinerea*, *Mucor racemosus*, *Rhizopus nigricans*, *Fusarium angustum*, *Penicillium rugulosum*, *Fusarium oxysporum*, *Geotrichum candidum*, *Torula beticola*, *Fusarium sulmorum*.

Table 1 and 2 show the results of research at different terms and temperatures of roots storage, previously affected by a certain type of gray rot causative agent.

Comparative analysis of Tables 1 and 2 shows the fact that among the selected Micromycetes cultures there take place gray rot causative agents, capable to destroy the root tissue and less active species, which can destroy the root tissue in much less active manner.

Table 1
Analysis of the activity of gray rot causative agent within sugar beet storage for 25 days at a temperature of 15-20 °C

Type of microorganism	Content of rotten tissue, %	
	after 10 days	after 25 days
<i>Botrytis cinerea</i>	20	49,3
<i>Mucor racemosus</i> + <i>Rhizopus nigricans</i>	26	58,2
<i>Fusarium angustum</i>	14	30,4
<i>Penicillium rugulosum</i>	10	17,5
<i>Fusarium oxysporum</i>	4,5	9
<i>Geotrichum candidum</i>	0,9	1,3
<i>Torula beticola</i>	1,7	3

Thus, the fungus *Botrytis cinerea* Pers is a very active gray rot causative agent, which is consistent with the results of other researchers [1, 17, 18]. Increasing of storage temperature by 15 ... 20 °C promotes the development of Mucorales and the most common types of *Mucor mucedo* and *Rhizopus nigricans*, which in a short time can turn the beet into unprocessable product. According to [12, 17], at the temperature conditions above 15 ... 20 °C these fungi far outweigh *Botrytis cinerea* Pers by degree of tissue destroying activity.

Table 2
The activity of gray rot causative agent within sugar beet storage for 45 days at a temperature of 0-5 °C

Type of microorganism	Content of rotten tissue, %	
	after 25 days	after 45 days
<i>Botrytis cinerea</i>	6,9	16,4
<i>Mucor mucedo</i> , <i>Rhizopus nigricans</i>	4,1	9,5
<i>Fusarium angustum</i>	1,1	2,64
<i>Penicillium rugulosum</i>	0,3	0,75
<i>Fusarium oxysporum</i>	0,5	0,9
<i>Torula beticola</i>	-	-
<i>Geotrichum candidum</i>	-	-

The sugar beet samples infected with *Geotrichum candidum* and *Torula beticola*, during storage at a temperature of 0 ... 5 °C for 45 days revealed the presence of external mycelium, but there was almost no development of gray rot causative agent.

Determination of the effectiveness of disinfectants activity. Since the active gray rot causative agents include filamentous fungi, a research was conducted to determine the effectiveness of antimicrobial action of the above disinfectants on Micromycetes species: *Rhizopus nigricans*, *Mucor mucedo*, *Botrytis cinerea*, *Fuzarium culmorum*, *Gliocladium roseum*, *Aspergillus niger*, *Penicillium rugulosum*. Moreover, given the extremely high difficulty of processing of sugar beet affected by mucous bacteriosis, the research applied the use of such culture as *Leuconostoc mesenteroides* species. Results of the research on the effectiveness of the above-mentioned disinfectants for certain types of microorganisms are given in Table 3.

Table 3
Results of the research on the effectiveness of antimicrobial action of some disinfectants on pure cultures of microorganisms by "holes in the thick agar" method

Disinfectants expenditure, g	The diameter of the activity zone of antimicrobial agents on microorganisms, mm							
	<i>Rhizopus nigricans</i>	<i>Mucor mucedo</i>	<i>Penicillium rugulosum</i>	<i>Botrytis cinerea Pens</i>	<i>Fizarium culmorum</i>	<i>Gliocladium roseum</i>	<i>Aspergillus niger</i>	<i>Leuconostoc mesenteroide</i>
Sanitarin								
0,0002	27	38	32	14	39	38	10	14
0,0004	38	No growth	40	24	No growth	No growth	14	20
0,0006	No growth			36	No growth	No growth	19	28
0,0008	No growth						25	32
Javel-kleyd								
0,0002	24	35	28	12	37	32	Solid growth	12
0,0004	32	40	34	22	No growth	40	8	20
0,0006	38	No growth	38	32	No growth	No growth	16	26
0,0008	No growth						22	30
Biodez								
0,0005	11	12	8	12	19	24	Solid growth	12
0,001	25	22	16	24	26	30	7	16
0,002	29	28	30	30	32	38	13	23
0,003	37	38	35	36	37	No growth	22	28
Hembar								
0,0005	14	14	10	15	20	25	4	13
0,001	26	24	17	26	28	30	8	18
0,002	32	30	32	33	34	39	14	24
0,003	No growth	40	38	40	No growth	No growth	23	29
Nobak								
0,00025	Solid growth							19
0,0005	Depressed growth the areaof the cup					–	Solid growth	24
Nobak-enzyme								
0,00025	28	26	22	22	23	–	20	22
0,0005	No growth					–	32	34
Betastab								
0,0025	Solid growth							32
0,005	Solid growth							38
Kamoran								
0,001	20	15	8	Depressed growth	25	–	12	24
0,002	23	16	14	16	24	–	14	36
0,004	28	22	16	16	28	–	17	40

Analysis of research results (Table 3) demonstrates the high efficiency of "Sanitarin", "Javel-Kleyd", "Biodez" and "Hembar" on mycelial fungi of different genus. The "Nobak-enzyme" should also be noted which compared to "Nobak" has showed high antimicrobial effect to a wider range of microorganisms.

As for the "Betastab", which is an environmentally safe product, derived from hydroxy acids of hops, it shows high efficacy in slime-forming bacteria, including the *Leuconostoc* genus, at the same time, at these values it is not effective on *Micromycetes*. Disinfectant "Kamoran" is active on different groups of microorganisms, including *Micromycetes* and slime-forming bacteria.

Fig. 1-4 graphically illustrates the results of research in order to identify the most effective disinfectants.

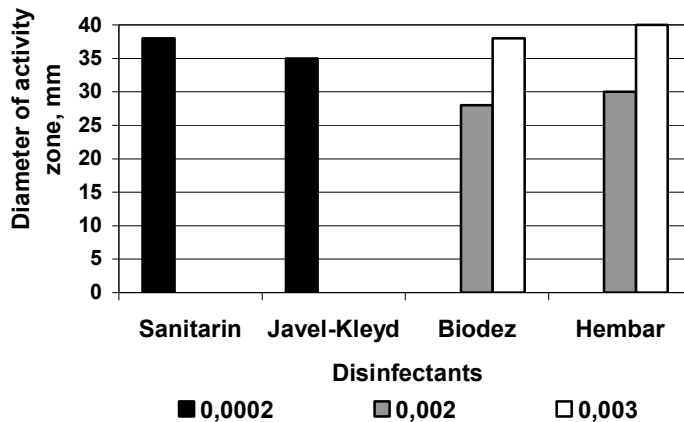

Figure. 1. The diameter of the zone of stunted growth of *Micromycetes* of *Mucor mucedo* species using disinfectants "Sanitarin", "Javel-Kleyd" at expenditures of 0,0002 g, "Biodez", "Hembar" – 0,002 and 0,003g

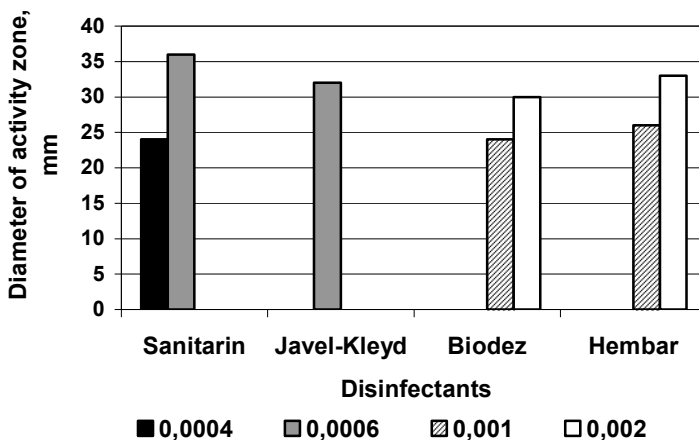

Figure. 2. The diameter of the zone of stunted growth of *Micromycetes* of *Botrytis cinerea* Pers species using disinfectants "Sanitarin", "Javel-Kleyd" at expenditures of 0,0004 g and 0,0006, "Biodez", "Hembar" – 0,001 and 0,002g

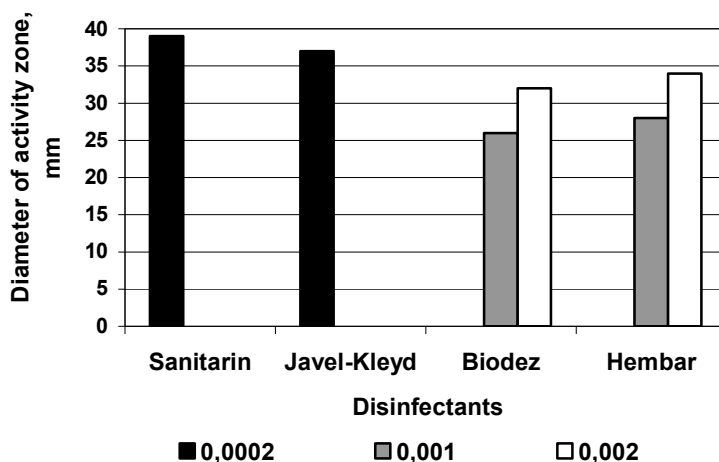

Figure. 3. The diameter of the zone of stunted growth of *Micromycetes of Fuzarium culmorum* species using disinfectants "Sanitarin", "Javel-Kleyd" at expenditures of 0,0002 g, "Biodez", "Hembar" – 0,001 and 0,002g

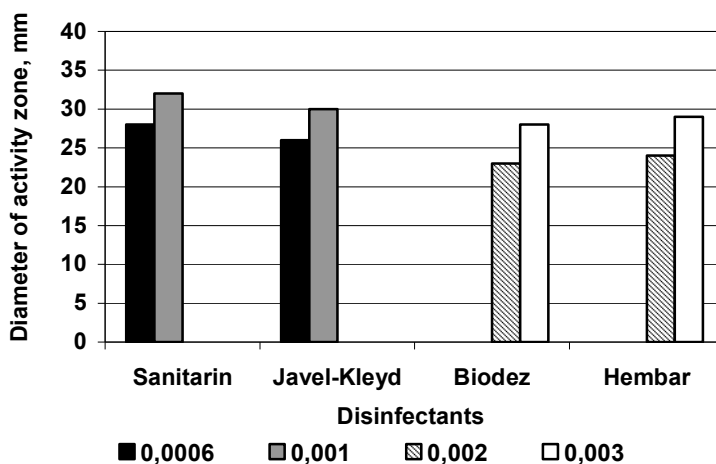

Figure. 4. The diameter of the zone of stunted growth of slime-forming microorganism culture of *Leuconostoc mesenteroides* species using disinfectants "Sanitarin", "Javel-Kleyd" at expenditures of 0,0006 and 0,0001 g, "Biodez", "Hembar" – 0,002 and 0,003g

Analysis of experimental research results on *Mucor mucedo* species (Fig. 1) has shown the high efficiency of "Sanitarin" and "Javel-Kleyd" at expenditures of 0,0002 g, as well as "Biodez", "Hembar" at expenditures of 0,002 and 0,003 g.

These products have slightly lower efficiency on *Botrytis sinerea* Pers species (Fig. 2). However, according to the results of research shown in Table 2, with increasing expenditures of the product based on dichloroisocyanuric acid sodium to 0.001 g the complete environment sterility is being achieved.

One of the most active gray rot causative agents are the Fuzarium genus. The results of the above products on Micromycetes of Fuzarium culmorum genus are presented in Fig. 3 and indicate the high efficiency of their actions at the following expenditures: "Sanitarin", "Javel-Kleyd" – 0,0002 g, "Biodez", "Hembar" – 0,002 g

The high efficiency of the presented products on slime-forming bacteria (Table 3, Fig. 4) should be noted. Thus, at the following disinfectant expenditures: "Sanitarin" 0,0004... 0,0006 g, the zone of stunting growth of slime-forming bacteria *Leuconostoc mesenteroides* is 20 ... 28 mm, which demonstrates the high efficiency of the product. The products based on PHMG are also effective on slime-forming bacteria. At the following disinfectant expenditures: "Hembar" and "Biodez" 0,002...0,003 g, the zone of stunting growth is 23...29 mm.

According to the analysis of experimental studies, we can conclude that products "Sanitarin", "Javel-Kleyd", "Hembar", "Biodez", "Nobak-enzyme", "Kamoran" have stable fungicidal and fungistatic effect against a broad spectrum of Micromycetes. In addition, the marked products are effective in inhibiting the development of slime-forming bacteria.

Given the results of the research, there is a proved need of the further study on the effectiveness of products based on chlorine ("Sanitarin", "Javel-Kleyd") and based on PHMG ("Hembar", "Biodez") for processing of sugar beet before entering into heap storage.

In order to establish the range of necessary expenditures for further processing of roots there was conducted an additional research to determine the effectiveness of their action on certain types of bacteria and yeast that characterize contaminating microflora of sugar beet.

The following bacteria were selected as objects of research: *Bacillus subtilis*, *B. megatherium* (gram positive spore-forming) ammonifying bacteria *Pseudomonas aeruginosa*, yeast *Sacharomyces cerevisia*, *Rhodotorula glutinis*, *Endomyces lactis*. Cultivation of microorganisms was performed on the following nutrient mediums:

a - MIA (meat infusion agar) and beetroot agar with inclusion of pure cultures of microorganisms of *Bacillus subtilis*, *B. megatherium*;

b - wort-agar with inclusion of pure cultures of microorganisms *Sacharomyces cerevisia*, *Rhodotorula glutinis*, *Endomyces lactis*.

Analysis of the research results (Table 4) shows the high efficiency of selected products on bacterial microflora of sugar beet production. The nature of the toxic action of chlorine-based chemicals is associated with oxidative processes in the cytoplasm of microbial cells, leading to its death [2]. Thus, in the case of using disinfectant "Sanitarin" in the range of active ingredient expenditure of 0,0002...0,0004 g there was observed the loss of vegetative forms of spore-forming mesophilic bacteria *B. subtilis*, *B. megatherium*, and the yeast *Rhodotorula glutinis*, *Endomyces lactis*.

Thus, according to the results of experimental research, there should be noted the high efficiency of selected products - "Sanitarin", "Javel-Kleyd", "Hembar", "Biodez" on a wide range of microorganisms.

As the products proposed for the research purpose are two groups of active substances, such as dichloroisocyanuric acid sodium and PHMG, the approximate values of reasonable expenditures for 100g of disinfectant working solution (Table 5) have been determined for their subsequent use for processing of sugar beet.

Table 4
Results of the research on the effectiveness of antimicrobial action of some disinfectants on pure cultures of microorganisms by "holes in the thick agar" method

Disinfectants expenditure, g	<i>B. subtilis</i>	<i>B. megatherium</i>	<i>Pseudomonas</i>	<i>Sacharomyces cerevisia</i>	<i>Rhodotorula glutinis</i>	<i>Endomyces lactis</i>
Sanitarin						
0,0002	25	24	28	17	32	34
0,0004	33	32	40	22	No growth	No growth
Javel-Kleyd						
0,0002	20	20	25	15	28	26
0,0004	32	32	36	19	35	33
0,0006	No growth	No growth	No growth	26	No growth	No growth
Biodez						
0,001	18	18	34	20	22	—
0,002	26	26	38	28	30	32
0,004	30	32	No growth	33	35	36
Hembar						
0,002	22	30	36	36	40	34
0,004	29	36	42	39	b.p	38

Table 5
Expenditures of disinfectants to inhibit activity of certain microorganisms

Culture of microorganism	"Sanitarin" product expenditure		"Biodez" product expenditure	
	g	In 100 g of the working solution	g	In 100 g of the working solution
<i>Rhizopus nigricans</i>	0,0002	0,02	0,001	0,1
<i>Mucor mucedo</i>	0,0001	0,01	0,002	0,2
<i>Penicillium rugulosum</i>	0,0002	0,02	0,002	0,2
<i>Botrytis cinerea Pers</i>	0,0004	0,04	0,002	0,2
<i>Fuzarium culmorum</i>	0,0001	0,01	0,001	0,1
<i>Gliocladium roseum</i>	0,00005	0,005	0,001	0,1
<i>Aspergillus niger</i>	0,0008	0,08	0,004	0,4
<i>Leuc. mesenteroides</i>	0,0006	0,06	0,0025	0,25
<i>B. subtilis</i>	0,0002	0,02	0,002	0,2
<i>B. megatherium</i>	0,0002	0,02	0,002	0,2

Conclusions

Thus, the research results have shown that the products "Sanitarin", "Javel-Kleyd", "Hembar", "Biodez", "Nobak-enzyme", "Kamoran" have stable fungicidal and fungistatic effect against a broad spectrum of Micromycetes which are gray rot causative agents and lead to poor technological quality of sugar beet. In addition, these agents are also effective in inhibiting the development of slime-forming bacteria.

According to results of the experimental research, we can conclude on the feasibility of the aforementioned means for sugar beet processing for the purpose of disinfection and prevention of gray rot. Whilst, the range of working solutions concentrations for root processing is as follows: for products based on active chlorine "Sanitarin", "Javel-Kleyd" - 0.02 ... 0.006%, based on PHMG - 0,1 ... 0,2%.

References

1. Chernyavska L.I., Zotova Yu.O., Leonteva O.V. (2002), Pro vtraty tsykozy vnaslidok mikrobiolohichnoho rozkladannya u tsukrovomu vyrobnytstvi, *Tsukor Ukainy*, 3, pp. 8-11.
2. Husyatynska N.A. (2006) Pytannya mikrobiolohichnoho kontrolyu ta vyboru antyseptyka pry ekstrahuvanni tsukrozy, *Tsukor Ukainy*, 6, pp. 12-15.
3. Walker, H. G., Rorem E. S., and McCready R. M. (1960), Compositional changes in diffusion juices from stored sugar beets, *Journal of the American Society of Sugar Beet Technologists*, 11, pp. 206-214.
4. Bugbee W. M., Cole D. F., and Nielsen G. E. (1975), Microflora and invert sugar in juice from healthy tissue of stored sugarbeet, *Applied Microbiology*, 29, pp. 780-781.
5. Wyse R. E. (1978), Effect of harvest injury on respiration and sucrose loss in sugarbeet roots during storage, *Journal of the American Society of Sugar Beet Technologists*, 20, pp. 193-202.
6. Cole D. F. (1977), Effect of cultivar and mechanical damage on respiration and storability of sugarbeet roots, *Journal of the American Society of Sugar Beet Technologists*, 19, pp. 240-245.
7. Tallgren A. H., Airaksinen U., Weissenberg R., Ojamo H., Kuusisto J., Leisola M. (1999), Exopolysaccharide-producing bacteria from sugar beets, *Applied and environmental microbiology*, 65(2), pp. 862-864.
8. Hein W., Rosner G., Emerstorfer F. (2008), Measures to prevent operational disturbances caused by dextran, *Sugar Industry*, 133(3), pp. 135-143.
9. Abdel-Rahman E. A., Schick R., Kurz T. (2007), Influence of dextran on sucrose crystallization, *Zuckerindustrie*, 132(6), pp. 453-460.
10. Rauh J. S. Cuddihy J. A., Falgout R. N. (1999), Analyzing dextran in the sugar industry: A review of dextran in the factory and a new analytical technique, *30th Biennial Meeting American Society of Sugar Beet Technologists at Orlando*, pp 29-40.
11. Helemskii M.Z., Pelts M. L., Sapozhnikova I. R. (1977), *Biokhimiya v sveklosakharnom proizvodstve*, Pishchevaya promyshlennost', Moscow.
12. Husyatynska N.A. (2009) *Mikrobiolohiya vyrobnytstv tsukrystykh rehovyn*, NUKhT, Kyiv.

13. Bruijn J.M. (2000), Processing of frost-damaged beets at CSM and use of dextranase, *Sugar Industry*, 125, pp. 898-902.
14. Cole D. F., W. M. Bugbee (1976), Changes in resident bacteria, pH, sucrose, and invert sugar levels in sugarbeet roots during storage, *Applied Microbiology*, 31, pp. 754-757.
15. Martini S.S., Narum J.A., Chambers K.H. (2001), Sugarbeet biochemical quality changes during pile storage. Part I. Sugars, *Journal of Sugar Beet Research*, 38 (1), pp. 35-53.
16. Kenter C., Hoffmann C. (2006), Changes in the quality of frost-damaged sugarbeet during storage as affected by temperature and variety, *Zuckerindustrie*, 13(2), pp. 85-91.
17. Bilai V.I. (1972), *Metody eksperymental'noy mikolohii*, Naukova dumka, Kyiv.
18. Bilai V.I. (1980), *Osnovy obshchyey mikolohiyi*, Vyshcha shkola, Kyiv.

Two-stage whey treatment by nanofiltration and reverse osmosis

Ivanna Kyrychuk¹, Valerii Myronchuk¹,
Yurii Zmiievskii¹, Serhii Holiachuk²

1 – National university of food technologies, Kyiv, Ukraine

2 – Lutsk national technical university, Lutsk, Ukraine

Abstract

Keywords:

Whey
Dairy
Nanofiltration
Reverse osmosis
Permeate

Article history:

Received 21.09.2015

Received in revised
form 14.11.2015

Accepted 24.12.2015

Corresponding author:

Ivanna Kyrychuk
E-mail:
ivanka_ki@mail.ru

Introduction. Treatment of whey, which is a by-product of cheese manufacturing process, is of great interest for dairy industry due to its high content of valuable and nutritional compounds. Although the development of complex whey treatment by membrane processes and use of its derivative products is still current.

Materials and methods. The raw whey and permeate after nanofiltration of whey were used for the study. The experiments were carried out in the pressure-driven laboratory setup of dead-end type using nanofiltration OPMN-P and reverse osmosis NanoRO membranes.

Results and Discussion. Considering high lactose content in whey and results obtained during lactose solutions filtration using OPMN-P membrane, it was proved that whey should be concentrated by nanofiltration to total solids of 20-22%. During whey concentration it was observed two stages of permeate flux decrease: rapid decrease of flux at the beginning of the process and further gradual flux decrease. The first is caused by membrane fouling and the latter is attributed to concentration polarization, formation and growth of the cake layer.

From the analysis of the obtained permeate flux-pressure and retention-pressure curves for reverse osmosis membrane NanoRO it was found that the rational value of pressure for the concentration of nanofiltration whey permeate is 3.0 MPa. At this pressure, permeate flux decreased twice with increase of solution concentration from 6 to 40 g/L, while average salt and lactose retention was 96.0% and 97.5% respectively. Based on the obtained results, the scheme of two-stage whey treatment was developed.

Conclusions. The obtained results of the study on two-stage whey treatment by nanofiltration and reverse osmosis can be used in the technology of complex whey processing in the dairy plant. It allows using all the whey components, obtaining the purified water for reuse and partially eliminating problem of environmental pollution by dairy plants.

Introduction

Whey is a by-product of cheese production which is rich in valuable components. Up to 1960's it was considered to be a waste of cheese manufacture, until the beginning of application of membrane processes in the dairy industry. Whey contains lactose (4.0-5.0%), proteins (0.6-1.0%), minerals (0.5-0.9 %), e.g., calcium, magnesium, phosphorus, vitamins, and milkfat in small concentrations [1-3]. It cannot be discharged to the environment or released into wastewaters because of its high content of organic compounds, high volume (often 90% of the mass of milk used) and its extremely high biological and chemical oxygen demand.

Nowadays, whey treatment by membrane processes is of great interest for researchers as via their using it is possible to recover useful products and to alleviate the pollution problem. The advance of whey treatment is caused by three main factors: an increase in costs of its release, the emergence of new technologies in extraction of whey protein and scientific researches, due to which valuable nutritional and biological properties of this product was found.

Among the membrane processes nanofiltration is the most suitable process for pre-concentration and partial demineralization of whey at the same time [4-6]. Due to high permeability of nanofiltration membranes for monovalent salts (such as NaCl, KCl) it is possible to remove them from whey. Monovalent ions (sodium, potassium and chloride) are undesirable components of food products due to their salty taste and negative health impacts [7, 8]. Moreover, such pre-concentration by nanofiltration is desirable before further whey treatment by electrodialysis for deep demineralization [9]. It can be explained by increasing whey conductivity and reducing its volume that results in lowering of load on electrodialysis equipment and increasing its efficiency [10]. However, nanofiltration membranes have low permeability for organic compounds with molecular weight less than 300 Da. That's why nanofiltration permeate may contain some lactose (up to 0.3%) that mainly depends on the nanofiltration membranes properties [11-14].

Whey permeate, which volume is approximately 65% of treated whey, is not usually used and is discharged to the waste. Considering the current demands to the composition and concentration of wastewaters its chemical oxygen demand must not exceed 500 mg O₂/dm³. Although, according to the literature data, chemical oxygen demand of nanofiltration whey permeate can reach up to 3000 mg O₂/dm³ [5, 15], mainly because of the lactose. Therefore, it must be pretreated before be released. The most appropriate method for its purification is reverse osmosis since reverse osmosis membranes allow concentrating and removing all the solutes presented in the feed and obtaining water for reuse.

The aim of this work was to study two-stage whey treatment by nanofiltration and reverse osmosis for the development of the whey processing technology. The choice of NF in the first stage was based on higher water flux at lower pressure. Reverse osmosis was chosen for the second stage due to high lactose and minerals rejection.

Materials and methods

The raw whey was used for the experiments. Its composition is presented in the Table 1. “Edible” lactose was used for preparation of model solutions of lactose.

Table 1

Composition of whey

Parameter	Fat	Protein	Lactose	Mineral salts	Dry matter
Concentration, %	0.35	1.0	3.5	0.7	6.0

A pressure-driven laboratory setup of dead-end type (Fig. 1) with membrane effective area of $1.38 \cdot 10^{-3} \text{ m}^2$ was used for the study of membrane separation of whey and its nanofiltration permeate. It consists of gas cylinder (not shown), membrane cell and magnetic stirrer 4. The membrane cell include two covers 1, 2 and metal cylinder 10. The porous support 6 and membrane 5 were placed in its bottom part and pressed by metal cylinder 10. Stir bar 3 impelled by magnetic stirrer 4 was put over the membrane 5. The special hole was made in the bottom cover 2 of the membrane cell for collecting permeate through the tube 11. With open fittings 7 and 8, a feed solution was introduced through one of them into the working chamber. Pressure gauge 9 was attached to fitting 8 for monitoring pressure in the middle of the unit and fitting 7 was connected to a pressure regulator mounted on the inert gas cylinder (not shown). The working pressure in the cell was created by opening the valves on the gas cylinder and the pressure regulator 12. The temperature of solutions during the experiments was in the limits $20 \pm 2^\circ\text{C}$. The temperature inside the membrane cell was measured controlled by thermal couple 13.

Nanofiltration membrane OPMN-P (ZAO STC “Vladipor”, Russian Federation) was used for whey concentration. Reverse osmosis membrane NanoRO (ZAO “RM Nanotech”, Russian Federation) was used for separation of nanofiltration whey permeate. Before separation, each membrane was soaked in deionized water for at least 12 h. Then they were compacted at pressure of 2.0 MPa for nanofiltration membrane and 4.0 MPa for reverse osmosis membrane by filtering distilled water through them until a steady flux was established.

The chemical composition of feed, retentate and permeate was determined by standard methods. Dry matter content was measured by a refractometer URL-1. Lactose concentration was determined by iodometric method. The mineral salts content was measured by a conductivity meter (HANNA Instruments DIST 1). Ion content of Ca^{2+} , Mg^{2+} was determined by atomic absorption (Pye Unicam 8800 UV/VIS, Philips). K^+ , Na^+ ion content was measured by flame photometer (PFM-U4.2, Analitpribor).

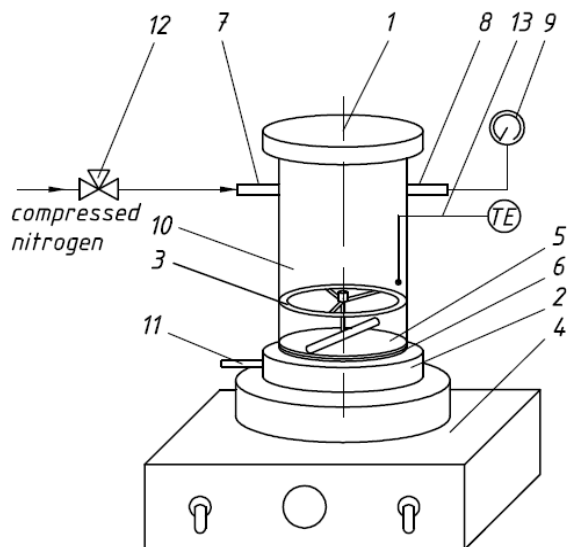

Fig. 1. Schematic diagram of the dead-end laboratory setup:

1, 2 – covers; 3 – stir bar; 4 – magnetic stirrer; 5 – membrane; 6 – porous support; 7, 8 – fittings; 9 – pressure gauge; 10 – metal cylinder; 11 – tube for permeate outlet; 12 – pressure regulator; 13 – thermal couple.

Permeate flux J ($L/(m^2 \cdot h^{-1})$) is the volume of permeate V (L) collected per unit membrane area S (m^2) per unit time t (s):

$$J = \frac{3600 \cdot V}{S \cdot t}. \quad (1)$$

The membrane retention R of any feed component was calculated as:

$$R = \left(1 - \frac{C_P}{C_R}\right) \cdot 100\%, \quad (2)$$

where C_P and C_R are the permeate and the retentate concentrations respectively.

Volume reduction ratio (VRR) vs. time was calculated as:

$$VRR = \frac{V_f(t)}{V_R(t)} = \frac{V_f(t)}{V_f(t) - V_P(t)}, \quad (3)$$

where $V_f(t)$, $V_R(t)$, $V_P(t)$ is the feed, retentate and permeate volume at time t , respectively.

Results and discussion

Analyzing the composition of whey (Table 1) [1, 2] it can be seen that lactose is up to 70% of its total solids. It is very important to concentrate all the lactose while whey processing because of its high chemical oxygen demand. That's why lactose rejection of nanofiltration membrane OPMN-P must be high. Therefore the separation characteristics of OPMN-P membrane were previously studied during filtration of lactose solutions.

Lactose filtration was carried out at pressure of 2.0 MPa. The obtained results are presented in Fig. 2. It can be seen that increase of lactose concentration from 5 to 18% leads to permeate flux decrease approximately by 10 times while lactose retention is very high and remains almost constant within 98%. The decrease in permeate flux is caused by concentration polarization and increase in osmotic pressure of the solution near the membrane surface. The osmotic pressure of lactose solution at concentration of 5% and 18% is 0.4 and 1.28 MPa respectively. Besides, the initial lactose crystallization may occur at high lactose concentration. Saturation of aqueous solution with lactose happens at concentration of 19.2 g /100 g H₂O at temperature of 20 °C [16]. Thus whey should be concentrated to dry matter content of 20-22%. High retention of OPMN-P membrane is probably caused by formation of dynamic membrane on membrane surface that additionally prevents lactose penetration through nanofiltration membrane into permeate. This phenomenon was discussed in the previous paper during reverse osmosis of lactose solutions [17].

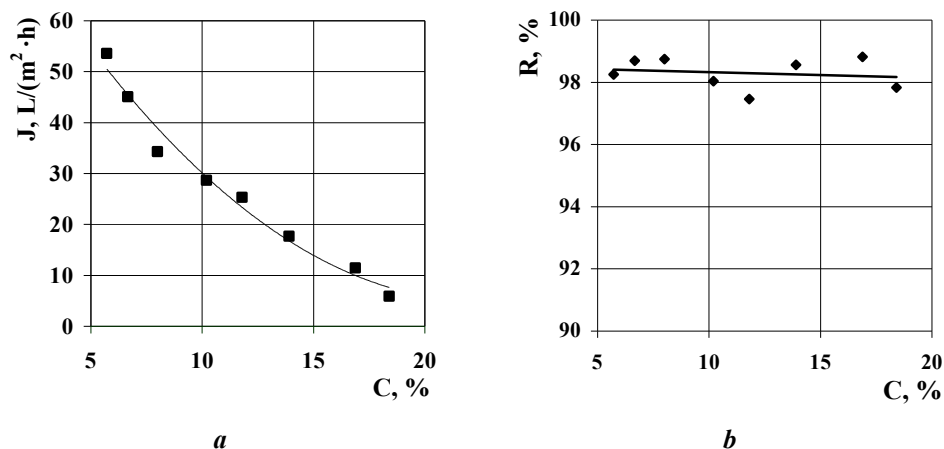

Fig. 2. Dependence of permeate flux J (a) and retention R (b) of OPMN-P membrane on concentration C of lactose solution ($\Delta P=2.0$ MPa, $t=20$ °C)

Whey concentration by nanofiltration was performed at 2.0 MPa that corresponds to high permeate flux and retention as was established in paper [12]. Appliance of higher pressure can cause severe membrane fouling and pore blocking [18]. Lower pressure is insufficient because of the low permeate flux and large membrane area needed for separation.

In Fig. 3 permeate flux is plotted vs. dry matter content during the concentration of whey. It can be observed that flux decreases with concentration mainly due to the increase in the osmotic pressure. The curve at the Fig. 3 can be divided into two parts: the rapid

permeate flux decrease at the beginning of the filtration and further gradual flux decrease. At the first stage, flux reduced almost twice, when the concentration of 8% was reached. The reason of this can be fouling of the membrane by whey components caused by adsorption of proteins on membrane surface [19]. Due to large molecular size of proteins, i.e. α -lactalbumin (3.0 nm), β -lactalbumin (4.0 nm), caseins (25-130 nm), its low mobility and small pore size of nanofiltration membrane (in the range of 0.1-1.0 nm) they deposit on membrane surface and form a dynamic membrane. At the second stage, the further decrease of permeate flux is attributed to concentration polarization, formation and growth of the cake layer [11, 19]. A cake layer is formed mainly of salts (calcium and phosphate ions) and partially of lactose. This layer creates an additional resistance to permeate flow.

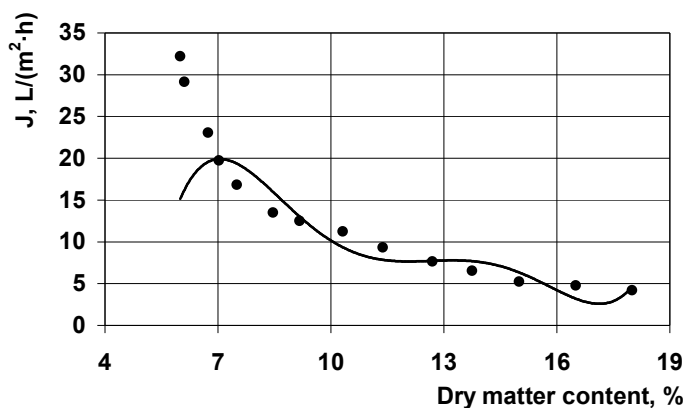

Fig. 3. Relationship of the permeate flux as a function of the dry matter content for OPMN-P membrane during whey concentration ($\Delta P=2.0$ MPa, $t=20$ °C)

The whey concentration was carried out until dry matter content reached 18-19%. At this point the permeate flux was less than 5 L/(m²·h) (Fig. 3). Retention of OPMN-P membrane was high for macromolecular substances (fat and protein). Lactose retention was in the range of 93-96% during whey concentration, and minerals retention was 56-62%. The composition of obtained permeate is shown in Table 2. As it can be seen, nanofiltration whey permeate consists of lactose (50% of total solids) and minerals (50%) presented by multivalent ions Ca^{2+} , Mg^{2+} and monovalent ions Na^+ , K^+ , Cl^- . In the complex processing technology for whey this permeate should be concentrated by reverse osmosis.

Table 2

Composition of nanofiltration whey permeate

Parameter	Total solids	Lactose	Minerals	Ca^{2+}	Mg^{2+}	Na^+	K^+	Cl^-
Value, g/L	6,0±0,1	3,0±0,1	2,9±0,1	0,015	0,009	0,264	1,248	1,364

The dependence of the permeate flux and retention for NanoRO membrane on pressure is shown in the Fig. 4 during filtration of whey permeate. It can be observed almost proportional rise of permeate flux J to the increase of the pressure ΔP to 4 MPa (Fig. 4 curve 1). Retention R for dry substances (Fig. 4 curve 2) increases with pressure up to a transmembrane pressure of 3.0 MPa. It increases slowly from 3.0 to 4.0 MPa, and obviously it will remain constant with further pressure rise. Based on this, pressure of 3.0 MPa was chosen to minimize energy consumption and to perform concentration of nanofiltration whey permeate by reverse osmosis.

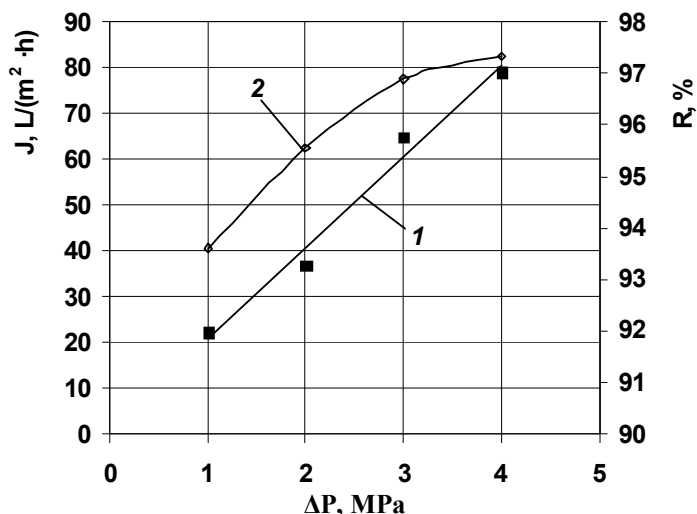

Fig. 4. Experimental data on separation of nanofiltration whey permeate for reverse osmosis membrane NanoRO:

- 1 – relationship of the permeate flux J as a function of the pressure ΔP ;
- 2 – relationship of retention R as a function of the pressure ΔP .

During concentration of nanofiltration whey permeate, flux decreased continuously with increasing VRR, i.e. feed concentration factor (Fig. 4 a). It reduced in 15 L/(m²·h) when VRR 1.5 was reached. At concentration factor higher than 1.5, the flux decreased gradually. This fact can be explained as a consequence of the concentration polarization layer formation on the membrane surface and membrane pore blocking by solution components. The pore blocking increases the membrane resistance while the retained particles on membrane creates an additional layer of resistance to the permeate flow. It also leads to the raise of osmotic pressure of the solution. At the end of the filtration, the concentration of nanofiltration whey permeate was 40 g/L including 26.2 g/L of lactose and 13.8 g/L of minerals.

Retention for lactose and minerals decreased gradually with VRR increase (Fig. 4 b). It can be explained as follows: due to formation of concentration polarization layer on membrane surface the filtration through the membrane occurs from the layers with the enhanced concentration. Thus the permeate concentration increases and retention decreases. The average salt retention was 96.0% and lactose retention was 97.5%. As the result, permeate contained 0.21 g/L of lactose and 0.12 g/L of mineral salts.

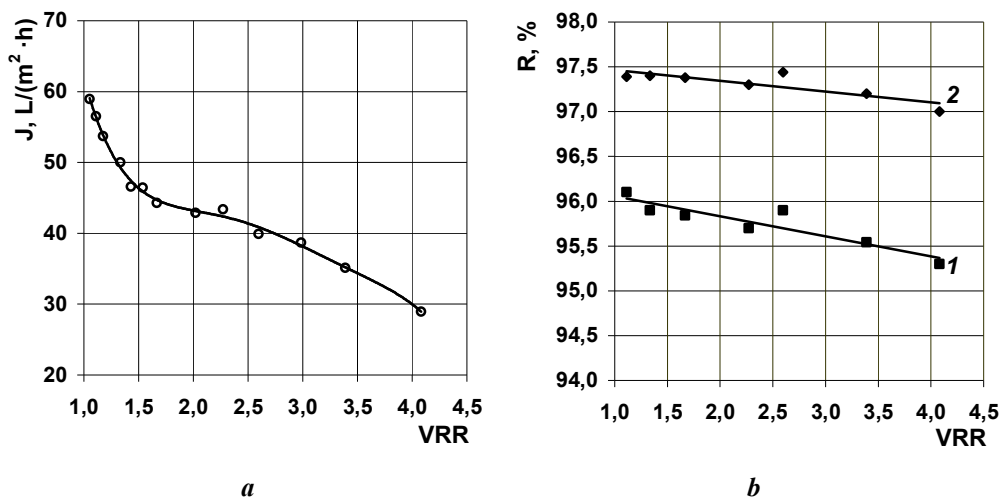

Fig. 4. Permeate flux J (a) and retention R (b) of NanoRO membrane during the concentration of nanofiltration whey permeate ($\Delta P=3.0$ MPa):
1 – minerals; 2 – lactose.

The scheme of two-stage whey treatment was developed based on the results of the study (Fig. 5). It includes nanofiltration at the first stage and reverse osmosis at the second. The obtained whey retentate after nanofiltration can be further concentrated up to 50% total solids by evaporation or demineralized by electrodialysis. The retentate after reverse osmosis can be used in non-lactose milk production to recover the mineral salt content [RU Patent No. 2305196, 2007]. Reverse osmosis permeate with low lactose and salt content can be discharged or used for cleaning, pre-rinsing, for washing floors and the outside of plant and vehicles. Such a two-stage membrane treatment allows all the whey components to be completely used and up to 90% of purified water on the amount of treated permeate after nanofiltration of whey to be received that can be reused in the dairy plant.

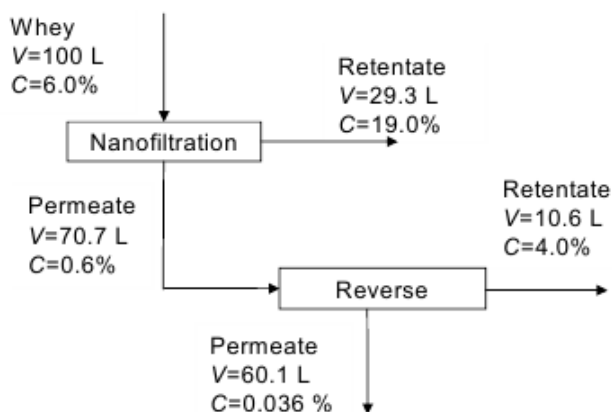

Fig. 5. Material flows on the process flow diagram of two-stage whey treatment by nanofiltration and reverse osmosis:
 V – volume of the solution; C – concentration of total solids.

Conclusions

Based on the results of the study it can be concluded that whey should be concentrated to total solids of 20-22% by nanofiltration according to the results of lactose solutions separation by nanofiltration. It was found that nanofiltration whey permeate contains 50% of organic compounds (lactose) and 50% of inorganic components. Due to its high chemical oxygen demand it should be previously treated before be discharged. The rational pressure for its concentration by reverse osmosis is 3.0 MPa. The benefit of using NF+RO cascade treatment of whey is full use of its components and the recovery of water suitable for reuse in the dairy plant.

References

1. Myronchuk V. H., Zmiievskiy Yu. H. (2013), *Membranni protsesy v tekhnologii kompleksnoi pererobky molochnoi syrovatky*, NUKhT, Kyiv.
2. Akpinar-Bayazit A., Ozcan T., Yilmaz-Ersan L. (2009), Membrane processes in production of functional whey components, *Mljekarstvo*, 59 (4), pp. 282-288.
3. Suárez E., Lobo A., Álvarez S., Riera F A., Álvarez R. (2006), Partial demineralization of whey and milk ultrafiltration permeate by nanofiltration at pilot-plant scale, *Desalination*, 198, pp. 274–281.
4. Bidhendi G. N., Nasrabadi T. (2006), Use of nanofiltration for concentration and demineralization in the dairy industry, *Pakistan Journal of Biological Sciences*, 9(5), pp. 991-994.
5. Yorgun M. S., Balcioglu I. A., Saygin O. (2008), Performance comparison of ultrafiltration, nanofiltration and reverse osmosis on whey treatment, *Desalination*, 229, pp. 204–216.
6. Turan M. (2004), Influence of filtration conditions on the performance of nanofiltration and reverse osmosis membranes in dairy wastewater treatment, *Desalination*, 170, pp. 83-90.
7. Rice G., Barber A., O'Connor A., Stevens G., Kentish S. (2009), Fouling of NF membranes by dairy ultrafiltration permeates, *Journal of Membrane Science*, 330, pp. 117–126.
8. Rice G., Barber A. R., O'Connor A. J., Stevens G. W., Kentish S. E. (2011), Rejection of dairy salts by a nanofiltration membrane, *Separation and Purification Technology*, 79, pp. 92–102.
9. Simova H., Kysela V., Cernin A. (2010), Demineralization of natural sweet whey by electrodialysis at pilot-plant scale, *Desalination and Water Treatment*, 14, pp. 170-173.
10. Varivoda A. A. (2014), Molochnaya syvorotka membrannoy obrabotki v tekhnologii plavlenykh syrov, *Mezhdunarodnyy nauchno-issledovatel'skiy zhurnal*, #2 (21), pp. 80-84.
11. Cuartas-Uribe B., Alcaina-Miranda M. I., Soriano-Costa E., Bes-Pia A. (2007), Comparison of the behavior of two nanofiltration membranes for sweet whey demineralization, *Journal of Dairy Science*, 90, pp. 1094–1101.
12. Zmiievskiy Yu. H., Kyrychuk I. I., Myronchuk V. H. (2013), Porivnialnyi analiz protsesiv nanofiltratsii ta zvorotnoho osmosu pry rozdilenni molochnoi syrovatky, *Naukovi pratsi Odeskoi natsionalnoi akademii kharchovykh tekhnologii*, 2(43), pp. 137-141.

13. Gong Y.-W., Zhang H.-X., Cheng X.-N. (2012), Treatment of dairy wastewater by two-stage membrane operation with ultrafiltration and nanofiltration, *Water Science & Technology*, 65.5, pp. 915-919.
14. Luo J., Ding L., Qi B., Jaffrin M. Y., Wan Y. (2011), A two-stage ultrafiltration and nanofiltration process for recycling dairy wastewater, *Bioresource Technology*, 102, pp. 7437–7442.
15. Balannec B., Vourch M., Rabiller-Baudry M., Chaufer B. (2005), Comparative study of different nanofiltration and reverse osmosis membranes for dairy effluent treatment by dead-end filtration, *Separation and Purification Technology*, 42, pp. 195–200.
16. Caric M., Akkerman J. C., Milanovic S., Kentish S. E., Tamime A. Y. (2009), Technology of Evaporators, Membrane Processing and Dryers, in: *Dairy Powders and Concentrated Products*, Blackwell Publishing Ltd, pp. 99-148.
17. Zmieviskii, Yu. G., Kirichuk I. I., Mironchuk V. G. (2014), Membrane treatment of wastewater obtained after the whey processing, *Journal of Water Chemistry and Technology*, 36(6), pp. 309-316.
18. Myronchuk V. G., Grushevskaya I. O., Kucheruk D. D., Zmieviskii Yu. G. (2013), Experimental study of the effect of high pressure on the of Whey nanofiltration processu an OPMNP membrane, *Petroleum Chemistry*, 53(7), pp. 439–443.
19. Kyrychuk I. I., Myronchuk V. H., Zmieviskyi Yu. H. (2013), Vyznachennia mekhanizmu zabrudnennia nanofiltratsiinykh membran pry rozdilenni molochnoi syrovatky, *Visnyk Kharkivskoho natsionalnoho tekhnichnoho universytetu silskoho hospodarstva imeni Petra Vasylenka «Suchasni napriamky tekhnolohii ta mekhanizatsii protsesiv pererobnykh ta kharchovykh vyrobnytstv»*, 140, pp. 147-152.

Temperatures distribution in the «larger sugar crystal–larger crystal sucrose solution–less crystal sugar sucrose solution–smaller sugar crystal–massecuite» cells system depending on the boiling sugar massecuite time

Taras Pogoriliyy

National university of food technologies, Kyiv, Ukraine

Abstract

Keywords:

Sugar
Sucrose
Temperature
Solution
Crystal
Massecuite

Article history:

Received 07.10.2015
Received in revised
form 04.12.2015
Accepted 24.12.2015

Corresponding author:

Taras Pogoriliyy
E-mail:
taras2212@gmail.com

Introduction. The process of obtaining crystalline sucrose is the most energy intensive in sugar production. For its control in this paper realized one of the following steps to create a mathematical model of the sucrose crystallization process.

Materials and methods. For solving the simultaneous 7 unsteady heat conduction problems in each area with constant and with variable thermophysical coefficients applied numerical methods (controlling volume method).

Results and discussion. Temperature distribution in each considered system cells area found from the non-stationary parabolic type differential equations in partial derivatives systems solution with mixed boundary conditions (the first kind - to the left edge of the first region "sucrose solution", and the other kind - for the right field last "massecuite") for two cases relative time boiling sugar massecuite τ/τ_c ($\tau/\tau_c = 0,15$ та $\tau/\tau_c = 1,0$).

It was found for each value τ/τ_c two types of solutions: 1 - temperature distribution in the system cells depending on the contact time with a heating pipe; 2 - temperature distribution in the system cells at the heating tubes outlet depending on the distance from the heating tube inner surface. In each of these cases were considered two different cases of non-stationary heat conduction problems: 1 - with constant and 2 - with variable thermophysical characteristics of each region separately. All cell temperature calculated based on variable thermal coefficients smaller in magnitude than the temperature calculated on the basis on constant thermal coefficients. Result of calculations showed that the maximum temperature difference obtained for non-stationary heat conduction problem with variables (compared with constant) thermophysical coefficients is between -0.67% at $\tau/\tau_c = 0,15$. Result of calculations showed that the maximum temperature difference obtained for non-stationary heat conduction problem with variables (compared with constant) thermophysical coefficients is between -0.32% at $\tau/\tau_c = 1,0$. This refers to the area that corresponds to the right border of sucrose solution smaller crystal.

Conclusions. Temperature distribution in the system cells found: a) within the heating tubes in each separate area system cells - depending on the time of contact $\tau_c(\tau/\tau_c)$; b) in each control volume central point areas at the heating tubes outlet - depending on the distance from the inner heating tube surface x .

Introduction

The process of obtaining crystalline sucrose is the most energy intensive in sugar production.

Current issues sucrose crystallization process and related processes that directly affect the process were engaged Tetiana Vasylenko and Sergii Vasylenko [1], Hugot E. [2, 6], Jenkins G.H. [3], Jiahui Chen [4], Baikow V.E. [5], Lauret P. [7], Alewijn W.F. [8], Semlali Aouragh Hassani [9] and Thomas R. Gillett [10].

Based on the literature review can conclude the following: to describe the crystallization of sucrose is extremely difficult and at present there is no single approach to this issue. Therefore, in this paper the author realized one of the following steps to create as the most complete mathematical model of the sucrose crystallization process.

This model should fully describe the heat and mass transfer process, which takes place between the multiphase system components such as sugar massecuite.

To describe these processes with all the technological factors that affect the sucrose crystallization, almost extremely difficult. Therefore, when creating a crystallization process mathematical model, which is idealized nature, a simplifications number adopted. In this case, the sugar massecuite presented as a cellular model [11]. Considered that each sugar crystal cell is surrounded by a corresponding between crystal sucrose solution cell over time boiling sugar massecuite. Hydrodynamic interactions occur only between cells. Heat and mass transfer processes occurring inside cells and between them. Simulation of unsteady heat and mass transfer processes carried out in several stages.

The first step is to find the temperature distribution in all cell systems. It is this and devoted to this work.

The second phase is necessary to find the value in each cell concentration solution of sucrose, sucrose value transferred between the cells and the amount of crystalline sugar that will crystallize (or dissolve) in a cell crystal sugar. It is understandable that this problem of unsteady diffusion mass transfer between cells, which consists of massecuite, is based completely on getting unsteady temperature field distribution system cells.

Because of the limited scope of this work was considered one of the following steps to create a mathematical model of the process of crystallization, which is related to finding solutions of non-stationary heat conductivity problem for the considered cell system. In this work, a continuation of [12] demonstrate the modeling process of unsteady heat transfer simultaneously two sugar crystals that are surrounded by the corresponding cells sucrose solution and simultaneously interact with massecuite.

Based on unsteady heat conduction problem solution is determined by temperature distribution in each component of cells that are inside the heating tube. Accepted the initial time $\tau_{c,0} = 0$, when the whole cells system adjudged (included) to the bottom of a vertically oriented heating tube. Final $\tau_{c,end}$ is the one time when the whole system comes out simultaneously with heating tubes in its upper part. It is understandable that $\tau_{k,1}$ value will depend on the relative time of boiling sugar massecuite, i.e., $\tau_{c,end} = \tau_{c,end}(\tau/\tau_c)$.

Note also that the crystal's, sucrose solution's and massecuite's cell thermal characteristics calculated based on the value of $\tau_{c,0}$, will depend on the relative time of boiling sugar massecuite τ/τ_c . Therefore, in relation to the value $\tau_{c,0}$ also use the account $\tau_{c,0} = \tau_{c,0}(\tau/\tau_c)$, though this value in this paper is assumed by zero.

Materials and methods

Similar to [12], assume that cell crystal sugar idealized version considered as rectangular parallelepipeds (prisms) with the corresponding proportion of the parties [13]. The cell sucrose solution thickness surrounding the appropriate size (more or less) cell sugar crystal, for each of these individual cases has the constant value across the lateral sugar crystal surface [14]. Sugar crystal cell contact each other through the appropriate sucrose solution cell and that densely adjoin one against another. The whole system of cells "larger sugar crystal–sucrose solution larger crystal- smaller crystal–sucrose solution smaller crystal" and massecuite by volume case schematically shown in Fig. 1.

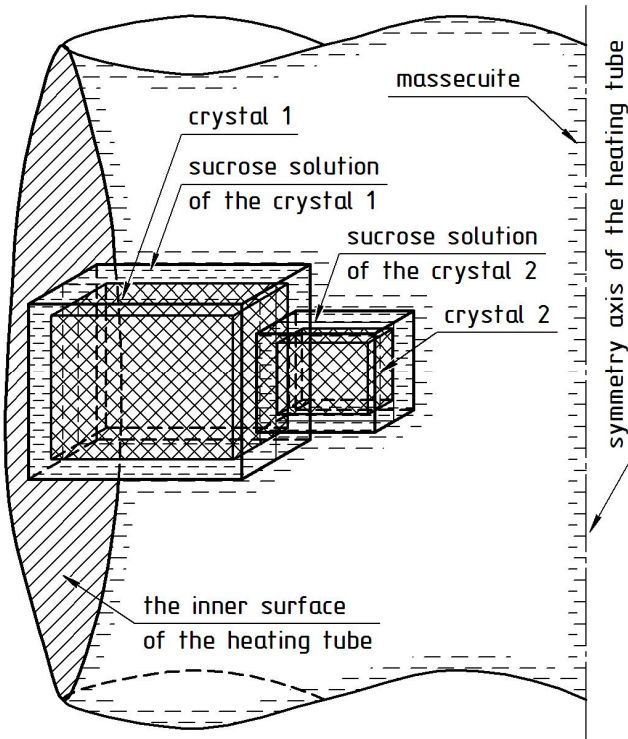

Fig. 1. Schematic location of the two sugar crystals with corresponding sucrose solution cells and massecuite inside the heating pipes by volume form

Due to by great complexity to find a solution of non-stationary heat conductivity problem for a system of cells in three-dimensional coordinate on the case (Fig. 1), the cells of the system applied method of transition from the volume equivalent to one-dimensional model of the coordinate. Thus, the volume model of the system massecuite and cells (Fig. 1) for unsteady heat conduction problem was ultimately presented as a 7 one-dimensional regions (Fig. 2) simultaneously in pairs come into contact with each other:

1. Left area larger crystal sucrose solution;
2. Larger crystal sugar;
3. Rights area larger crystal sucrose solution;

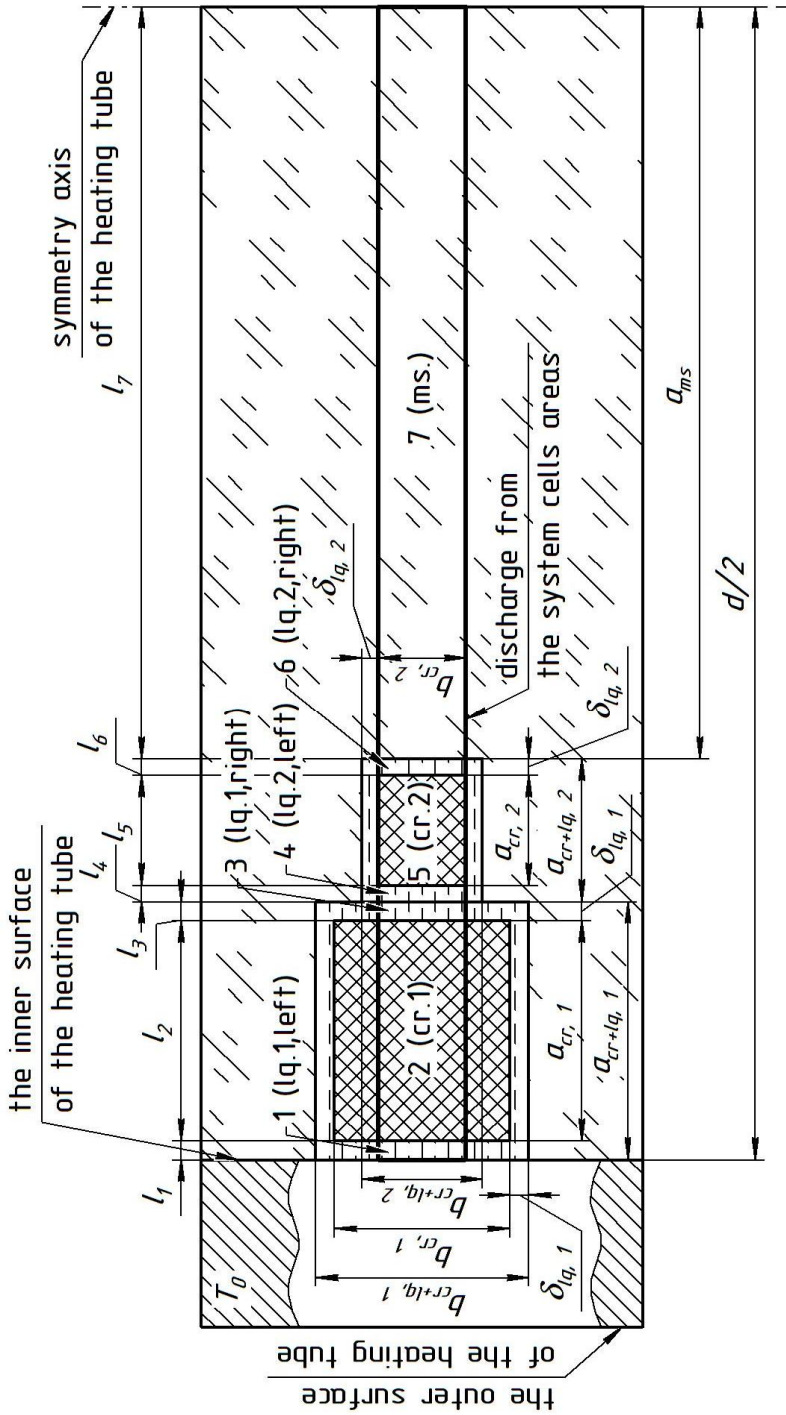

Fig. 2. Discharge from the volumetric system cells and massecuite 7 one-dimensional areas: "left side larger crystal sucrose solution cell—larger crystal cell—right side larger crystal sucrose solution cell—left side smaller crystal sucrose solution cell—smaller crystal cell—right side smaller crystal sucrose solution cell—massecuite", taking participate in the heat process.

4. Sucrose solution left area smaller crystal;
5. Smaller crystal sugar;
6. Rights area smaller crystal sucrose solution
7. Masseccuite.

Note that in Fig. 2 shows a one-dimensional area as two-dimensional region with the same height for all, equal to the average side $b_{cr+li,2}$ smaller crystal.

Problem is considered for the following two cases:

I - with constant and

II - with variable

thermophysical characteristics.

In the case of (I), when considering the nonstationary heat conduction problem with simultaneously in all areas constant thermophysical characteristics, methods of calculation as follows. We consider that at the initial moment $\tau_c = \tau_{c,0}(\tau/\tau_c)$ system cells located in the lower entry point in the heating pipe. According to the current value of the boiling sugar masseccuite relative time τ/τ_c at the initial moment $\tau_c = \tau_{c,0}(\tau/\tau_c)$ for each area separately records all technological factors. For cell sucrose solution technological factors are the following values: dry substances $DS(\tau/\tau_c)$ and purity $P(\tau/\tau_c)$. For cell masseccuite is an additional value mass content crystals $CR(\tau/\tau_c)$. Note that each fixed value relative boiling sugar masseccuite time τ/τ_c values of all technological factors remain constant during the entire calculation process to determine the temperature. This means that during the contact time $\tau_{k,0}(\tau/\tau_{ii}) \leq \tau_k \leq \tau_{k,end}(\tau/\tau_{ii})$ of system cells from the heating tube inner surface.

For each time considered the value boiling sugar masseccuite relative time τ/τ_c initial temperature for all areas simultaneously taken constant and equal to T_0 , i.e. $T_{0,i} = T_{0,i}(\tau/\tau_{ii}) = \text{const}$, ($i=1, \dots, 7$).

Further, at predetermined meaning τ/τ_c based on fixed technological factors and initial temperature $T_{0,i} = \text{const}$, ($i=1, \dots, 7$), the corresponding values thermal characteristics are calculated in each separate area: density $\rho_i(DS_i(\tau/\tau_c), P_i(\tau/\tau_c), CR_i(\tau/\tau_c), T_{0,i})$, ($i=1, \dots, 7$), the thermal conductivity $\lambda_i(DS_i(\tau/\tau_c), P_i(\tau/\tau_c), CR_i(\tau/\tau_c), T_{0,i})$, ($i=1, \dots, 7$), and heat capacity coefficients $c_i(DS_i(\tau/\tau_c), P_i(\tau/\tau_c), CR_i(\tau/\tau_c), T_{0,i})$, ($i=1, \dots, 7$).

It is these thermal conductivity values λ_i , density ρ_i and heat capacity c_i ($i=1, \dots, 7$), in each separate area fixed and remain constant over the system cells contact time $\tau_{k,0}(\tau/\tau_{ii}) \leq \tau_k \leq \tau_{k,end}(\tau/\tau_{ii})$ from the heating tube inner surface.

Thus, for the first case the constant thermal characteristics for each area separately (Fig. 2) need to find a system solution (1) simultaneously for the seven non-stationary differential equations systems parabolic type in partial derivatives (heat conductivity equation) for the corresponding seven one-dimensional regions that pairs in contact with each other, with mixed boundary conditions (2) - (5) and initial conditions (6):

$$\frac{\partial T_i}{\partial \tau} = a_i \frac{\partial^2 T_i}{\partial x^2}, \quad (i = \overline{1, 7}), \quad (1)$$

$$T_1(0, \tau) = T_0 = 100, \quad (2)$$

$$-\lambda_i \frac{\partial T_i}{\partial x} \Big|_{x=l_i} = -\lambda_{i+1} \frac{\partial T_{i+1}}{\partial x} \Big|_{x=l_i}, \quad (i = \overline{1, 6}), \quad (3)$$

$$T_i \Big|_{x=l_i} = T_{i+1} \Big|_{x=l_i}, \quad (i = \overline{1, 6}), \quad (4)$$

$$\left. \frac{\partial T_7}{\partial x} \right|_{x=l_7} = 0, \quad (5)$$

$$T_i(x, 0) = T_{i,0} = 75, (i = \overline{1,7}). \quad (6)$$

In the case of (II) when considering unsteady heat conduction problems with variables simultaneously in all areas of thermophysical characteristics, methods of calculation is different.

First, as in the previous case (I) with constant thermophysical characteristics according to the current value of the boiling sugar massecuite relative time τ/τ_c at the initial moment $\tau_c = \tau_{c,0}(\tau/\tau_c)$ for each area separately records all technological factors: dry substances $DS(\tau/\tau_c)$, purity $P(\tau/\tau_c)$ and value mass content crystals $CR(\tau/\tau_c)$.

Just as in the case of (I), each fixed value boiling sugar massecuite relative time τ/τ_c values of all process parameters remain constant during the whole time of the temperature determine calculation: $\tau_{c,0}(\tau/\tau_c) \leq \tau_c \leq \tau_{c,end}(\tau/\tau_c)$.

As in the cases (I) for each time considered the value boiling sugar massecuite relative time τ/τ_c initial temperature for all areas simultaneously taken constant and equal to T_0 , i.e. $T_{0,i} = T_{0,i}(\tau/\tau_c) = \text{const}, (i = \overline{1, \dots, 7})$.

At predetermined meaning τ/τ_c based on fixed technological factors and initial temperature $T_{0,i} = \text{const}, (i = \overline{1, \dots, 7})$, the corresponding values thermal characteristics are calculated in each separate area: density $\rho_i(DS_i(\tau/\tau_c), P_i(\tau/\tau_c), CR_i(\tau/\tau_c), T_{0,i}), (i = \overline{1, \dots, 7})$, the thermal conductivity $\lambda_i(DS_i(\tau/\tau_c), P_i(\tau/\tau_c), CR_i(\tau/\tau_c), T_{0,i}), (i = \overline{1, \dots, 7})$, and heat capacity coefficients $c_i(DS_i(\tau/\tau_c), P_i(\tau/\tau_c), CR_i(\tau/\tau_c), T_{0,i}), (i = \overline{1, \dots, 7})$.

The first step in calculating time $\tau_{c,1} = 1 \cdot \Delta\tau_c + \tau_{c,0}(\tau/\tau_c)$ in each region on the basis of the thermal characteristics initial values is calculated the current temperature $T_i(x_i, \tau_{c,1}), (i = \overline{1, \dots, 7})$, separately for each control volume in all system cells areas.

Further, the second and each subsequent j -th calculating time step $\tau_{c,j} = j \cdot \Delta\tau_c + \tau_{c,0}(\tau/\tau_c), (j = \overline{2, 3, 4, \dots})$, the calculations algorithm to determine the temperature distribution in areas with variable thermophysical characteristics consists the following two stages:

1 - according to the previous $(j-1)$ -th calculation time step $\tau_{c,j-1} = (j-1) \cdot \Delta\tau_c + \tau_{c,0}(\tau/\tau_c), (j = \overline{2, 3, 4, \dots})$, temperature distribution $T_i(x_i, \tau_{c,j-1}), (i = \overline{1, \dots, 7}; j = \overline{2, 3, 4, \dots})$, found in all areas under fixed all technological factors values compute the thermal characteristics value of each region separately:

$$\begin{aligned} & \rho_i(DS_i(\tau/\tau_c), P_i(\tau/\tau_c), CR_i(\tau/\tau_c), T_i(x_i, \tau_{c,j-1})), \\ & \lambda_i(DS_i(\tau/\tau_c), P_i(\tau/\tau_c), CR_i(\tau/\tau_c), T_i(x_i, \tau_{c,j-1})), \\ & c_i(DS_i(\tau/\tau_c), P_i(\tau/\tau_c), CR_i(\tau/\tau_c), T_i(x_i, \tau_{c,j-1})), \\ & i = \overline{1, \dots, 7}; j = \overline{2, 3, 4, \dots}; \end{aligned}$$

2 - on basis of received values in the preceding paragraph, thermal characteristics of the j -th time step $\tau_{c,j} = j \cdot \Delta\tau_c + \tau_{c,0}(\tau/\tau_c), (j = \overline{2, 3, 4, \dots})$, in each area calculated current temperature values $T_i(x_i, \tau_{c,j}), (i = \overline{1, \dots, 7}; j = \overline{2, 3, 4, \dots})$, separately for each control volume in all system cells areas.

The first and second paragraphs calculation algorithm to conduct until the whole system cells located inside the heating tubes, that is, to the time $\tau_{c,end}(\tau/\tau_c)$.

Thus, in this second case, all the thermal characteristics for each separate region for each j -th time step calculation will take into account technological characteristics and current temperature $T_i(x_i, \tau_{c,j}), (i = \overline{1, \dots, 7}; j = \overline{1, 2, 3, \dots})$, in these areas.

Thus, for the second case the variable thermal characteristics for each area separately (Fig. 2), need to find the system solution (1*) simultaneously for the seven non-stationary differential equations systems parabolic type in partial derivatives (heat conductivity equation) for the corresponding seven one-dimensional regions that pairs in contact with each other, with mixed boundary conditions (2*) - (5*) and initial conditions (6*):

$$\rho_i(DS_i, P_i, CR_i, T_i) c_i(DS_i, P_i, CR_i, T_i) \frac{\partial T_i}{\partial \tau} = \frac{\partial}{\partial x} \left(\lambda_i(DS_i, P_i, CR_i, T_i) \frac{\partial T_i}{\partial x} \right), (i = \overline{1, 7}), \quad (1^*)$$

$$T_1(0, \tau) = T_0 = 100, \quad (2^*)$$

$$-\lambda_i(DS_i, P_i, CR_i, T_i) \frac{\partial T_i}{\partial x} \Big|_{x=l_i} = -\lambda_{i+1}(DS_{i+1}, P_{i+1}, CR_{i+1}, T_{i+1}) \frac{\partial T_{i+1}}{\partial x} \Big|_{x=l_i}, (i = \overline{1, 6}), \quad (3^*)$$

$$T_i \Big|_{x=l_i} = T_{i+1} \Big|_{x=l_i}, (i = \overline{1, 6}), \quad (4^*)$$

$$\frac{\partial T_7}{\partial x} \Big|_{x=l_7} = 0, \quad (5^*)$$

$$T_i(x, 0) = T_{i,0} = 75, (i = \overline{1, 7}). \quad (6^*)$$

Conditions (4) and (4*) - the so-called conditions "crosslinking".

The initial temperature system cells assumed the same for all regions simultaneously and equally 75°C. The temperature of the heating tube's inner wall assumed constant over the tube entire height and equal to 100 °C. It was this temperature has been taken as a first region's left boundary condition (Fig. 2).

All other boundary conditions (3) - (4) and (3*) - (4*) - expressing an ideal heat exchange law between the neighboring cells of the system.

Boundary conditions (5) and (5*) derived from the physical sense, because the problem in three-dimensional case considered as axisymmetrical (the last seven region right end in Fig. 2 coincides with the heating tubes symmetry axis).

Solve unsteady differential equations system (1) with constant thermophysical characteristics with appropriate boundary conditions (2) - (5) and corresponding initial condition (6) an analytical method [15] is difficult.

Solve unsteady differential equations system (1*) with variable thermophysical characteristics with appropriate boundary conditions (2*) - (5*) and corresponding initial condition (6*) an analytical method [15] is virtually impossible. That is why in this case were applied numerical methods using well-known controlling volume methods [16, 17].

Discretization in time was $\Delta\tau_c = 0,001$ s. Grid splitting is assumed to irregular when coordinate sampling discretization conducting. Each region separately (Fig. 2) smashed on the corresponding control volumes number: $n_1 = n_3 = n_4 = n_6 = 10$, $n_2 = n_5 = 20$, $n_7 = 100$.

The cells values are accepted the following sizes: $a_{cr,1} = 5,0 \cdot 10^{-4}$ m, $\delta_{lq,1} = 4,29 \cdot 10^{-5}$ m, $a_{cr,2} = 2,5 \cdot 10^{-4}$ m, $\delta_{lq,2} = 3,73 \cdot 10^{-5}$ m, $a_{ms} = 4,83896 \cdot 10^{-2}$ m.

Based on the calculations, the end contact time of the cell system with the heating tubes wall for boiling relative time $\tau/\tau_c = 0,15$ is $\tau_{c,end} = 3,95$ sec, and with $\tau/\tau_c = 1,0$ is $\tau_{c,end} = 67,93$ sec.

Results and discussion

The calculations conducted for the following values of the relative boiling sugar massecuite time $\tau/\tau_c = 0,15; 0,2; 0,3; 0,4; 0,5; 0,6; 0,7; 0,8; 0,9; 1,0$ for the aforementioned non-stationary heat conduction problems (1) - (6) and (1*) - (6*).

Because of limited volume in this paper are given only two cases relative boiling sugar massecuite time τ/τ_c : at the winding crystals time ($\tau/\tau_c = 0,15$) and complete the boiling sugar massecuite time ($\tau/\tau_c = 1,0$). In each of these cases the numerical calculations results obtained as the solution of equations system (1) - (6) with constant thermophysical characteristics and as the solution of equations system (1*) - (6*) with variable thermophysical characteristics were are presented in the following two cases.

1) The first case is considered the coordinate average temperatures distribution in each one-dimensional region (Fig. 2) depending on the contact time τ_c , ($0 \leq \tau_c \leq \tau_{c,1}(\tau/\tau_c)$) of all system cells with the heating tube inner surface for sustainable (hereafter denoted through index «cnst») and variables (denoted by the index «var») thermal characteristics of this system cells components.

2) The second case are given the final coordinate x distribution (x is a distance from the inner heating tube surface to its symmetry axis) temperatures in one-dimensional areas (Fig. 2) corresponding to the outlet system cells from the heating tubes.

The graphics is also presented for the sustainable (index «cnst») and variable (index «var») thermal characteristics case at $\tau/\tau_c = 0,15$ and $\tau/\tau_c = 1,0$.

The first case calculations temperature distribution results in the regions when $\tau/\tau_c = 0,15$ is shown in Fig. 3, when $\tau/\tau_c = 1,0$ is shown in Fig. 4.

The final calculations results in time $\tau_{c,end}$ will present in a table 1 for the temperatures comparison. As mentioned, the calculated contact time is $\tau_{c,end} = 3,95$ sec at boiling sugar massecuite relative time $\tau/\tau_c = 0,15$.

Table 1
The average values temperature distribution in the system cells areas at the heating tubes outlet (with a relative massecuite boiling time $\tau/\tau_c = 0,15$ contact time is $\tau_{c,end} = 3,95$ sec)

$\tau_{c,end} = 3,95$ sec ($\tau/\tau_c = 0,15$)	T ₁	T ₂	T ₃	T ₄	T ₅	T ₆	T ₇
T _{cnst}	99,54691	94,80251	90,24084	89,49273	87,33393	85,29493	75,9377
T _{var}	99,52878	94,45600	89,67761	88,93455	86,75772	84,72311	75,87787
$T_{i,var} / T_{i,cnst}$	0,99982	0,99634	0,99376	0,99376	0,99340	0,99330	0,99921
$T_{i,cnst} / T_{i,var}$	1,00018	1,00367	1,00628	1,00628	1,00664	1,00675	1,00079
$\frac{T_{i,var} - T_{i,cnst}}{T_{i,cnst}} 100\%$	-0,0182	-0,3655	-0,6241	-0,6237	-0,6598	-0,6704	-0,0788
$\frac{T_{i,cnst} - T_{i,var}}{T_{i,var}} 100\%$	0,0182	0,3668	0,6281	0,6276	0,6642	0,6749	0,0789

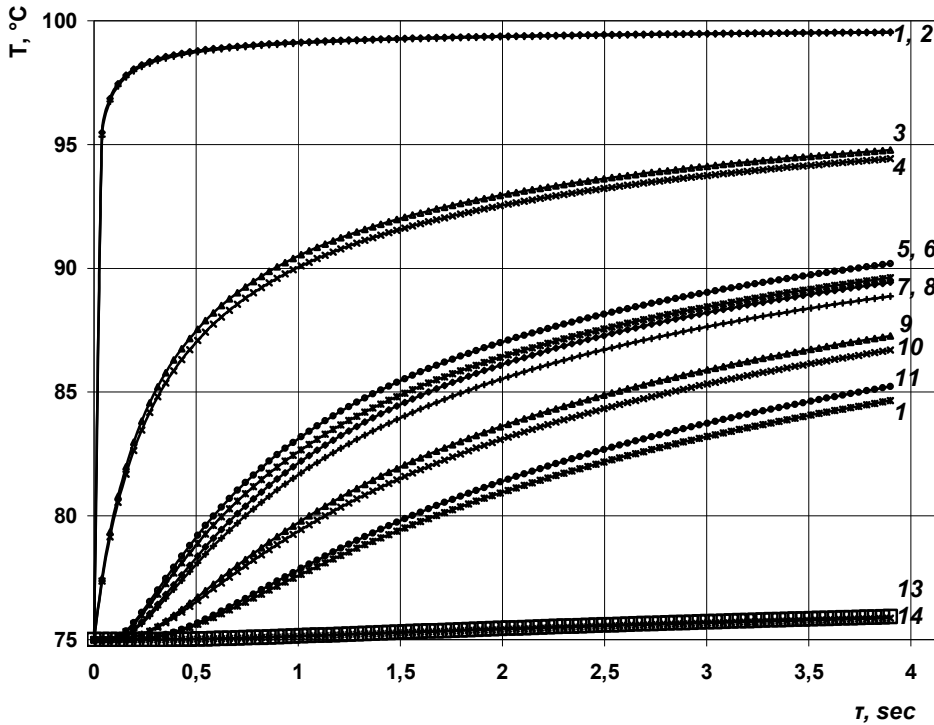

Fig. 3. The areas temperatures distribution (the average values in the area along the coordinate) depending on the contact system cells time with the inner heating tubes surface (relative time massecuite boiling $\tau/\tau_c = 0,15$):

- Region 1 (left side of the larger crystal sucrose solution cell):
 - 1 – $T_{1, \text{cnst}}$ (all region 1 thermal characteristics are constant);
 - 2 – $T_{1, \text{var}}$ (all region 1 thermal characteristics are variable);
- Region 2 (larger sugar crystal):
 - 3 – $T_{2, \text{cnst}}$ (all region 2 thermal characteristics are constant);
 - 4 – $T_{2, \text{var}}$ (all region 2 thermal characteristics are variable);
- Region 3 (sucrose solution larger sugar crystal, right side of the cell):
 - 5 – $T_{3, \text{cnst}}$ (all region 3 thermal characteristics are constant);
 - 6 – $T_{3, \text{var}}$ (all region 3 thermal characteristics are variable);
- Region 4 (sucrose solution smaller sugar crystals, the left side of the cell):
 - 7 – $T_{4, \text{cnst}}$ (all region 4 thermal characteristics are constant);
 - 8 – $T_{4, \text{var}}$ (all region 4 thermal characteristics are variable);
- Region 5 (smaller sugar crystal):
 - 9 – $T_{5, \text{cnst}}$ (all region 5 thermal characteristics are constant);
 - 10 – $T_{5, \text{var}}$ (all region 5 thermal characteristics are variable);
- Region 6 (sucrose solution smaller sugar crystal, right side of the cell):
 - 11 – $T_{6, \text{cnst}}$ (all region 6 thermal characteristics are constant);
 - 12 – $T_{6, \text{var}}$ (all region 6 thermal characteristics are variable);
- Region 7 (massecuite):
 - 13 – $T_{7, \text{cnst}}$ (all region 7 thermal characteristics are constant);
 - 14 – $T_{7, \text{var}}$ (all region 7 thermal characteristics are variable).

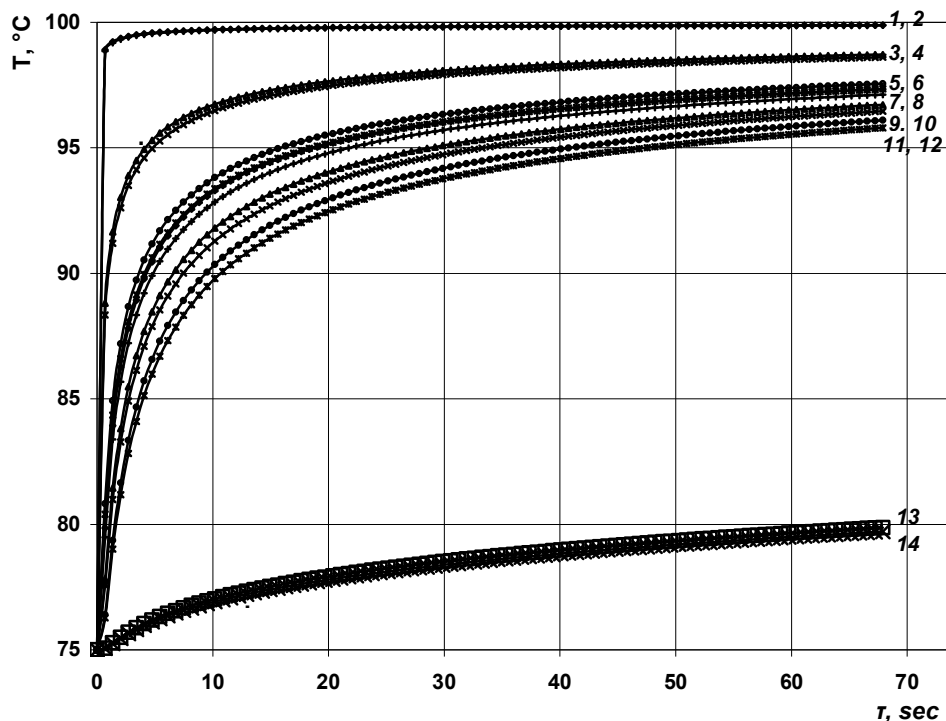

Fig. 4. The areas temperatures distribution (the average values in the area along the coordinate) depending on the contact system cells time with the inner heating tubes surface (relative time massecuite boiling $\tau/\tau_c = 1,0$).
 * Designations the same as in Fig. 3.

The calculations results of relative temperature change in each area in the Table. 1 also shows. The constant coefficients calculations result for the relative temperatures change case is represented by $T_{i,var} / T_{i,cnst}$. The variable coefficients calculations result for the relative temperatures change case is represented by $T_{i,cnst} / T_{i,var}$. The calculations results of relative temperature growth in each area in the Table. 1 also shows.

In the case of relative temperatures growth the calculations result with constant coefficients represented by $((T_{i,var} - T_{i,cnst}) / T_{i,cnst}) \cdot 100\%$. In the case of relative temperatures growth the calculations result with variable coefficients represented by $((T_{i,cnst} - T_{i,var}) / T_{i,var}) \cdot 100\%$. Note the last two cases, the result is represented as a percentage (%).

As seen from these last data take account variable (compared with constant) thermal characteristics results in a lower values for each temperature region.

The greatest difference between the temperatures about -0.67% is obtained in the sixth region corresponding to the right side of the sucrose solution smaller crystal cell.

Further, the calculated contact time is $\tau_{c,end} = 67,93$ sec at boiling sugar massecuite relative time $\tau/\tau_c = 1,0$. Thus, we get the following temperature distribution final data at time $\tau_{k,end} = 67,93$ s, which are presented in Table 2.

Table 2

The average values temperature distribution in the system cells areas at the heating tubes outlet (with a relative massecuite boiling time $\tau/\tau_c = 1,0$ contact time is $\tau_{c,end} = 67,93$ sec)

$\tau_{c,end} = 67,93$ sec ($\tau/\tau_c = 1,0$)	T ₁	T ₂	T ₃	T ₄	T ₅	T ₆	T ₇
T _{cnst}	99,88552	98,71697	97,55134	97,33923	96,71924	96,10151	79,87282
T _{var}	99,87960	98,60743	97,34421	97,12354	96,45859	95,79789	79,71489
T _{i,var} / T _{i,cnst}	0,99994	0,99889	0,99788	0,99778	0,99731	0,99684	0,99802
T _{i,cnst} / T _{i,var}	1,00006	1,00111	1,00213	1,00222	1,00270	1,00317	1,00198
$\frac{T_{i,var} - T_{i,cnst}}{T_{i,cnst}} 100\%$	-0,0059	-0,1110	-0,2123	-0,2216	-0,2695	-0,3159	-0,1977
$\frac{T_{i,cnst} - T_{i,var}}{T_{i,var}} 100\%$	0,0059	0,1111	0,2128	0,2221	0,2702	0,3169	0,1981

The calculations results of relative temperature growth in each area in the Table. 2 also shows. The constant coefficients calculations result for the relative temperatures change case is represented by $T_{i,var} / T_{i,cnst}$. The variable coefficients calculations result for the relative temperatures change case is represented by $T_{i,cnst} / T_{i,var}$. The greatest difference between the temperatures about -0.32% is obtained in the sixth region corresponding to the right side of the sucrose solution smaller crystal cell.

It is understandable that calculating an approximate temperature distribution for practical purposes is sufficient to use a non-stationary heat conduction problem solution for the thermal characteristics constant coefficients case in each individual area. This greatly facilitates the creation of such a algorithm calculations program and reduces the calculation time. However, in the future it will be necessary to find the concentrations distribution on each individual sucrose solution cell. Therefore it would be to carry out calculations to determine the temperature distribution in the system cells, taking into account variable thermal characteristics. This is according to the author more consistent with the real physical mass sucrose crystallization process.

Next, consider the calculations results for the second case, the temperature distribution depending on the distance x from the heating tube inner surface to its symmetry axis.

The above case temperature distribution with a massecuite boiling relative time $\tau/\tau_c = 0,15$ is shown in Fig. 5, while $\tau/\tau_c = 1,0$ – is shown in Fig. 6.

As seen from Fig. 5 and Fig. 6, the thickness of the overheated liquid different.

When $\tau/\tau_c=0,15$ temperature system cells at a small distance from the wall heating significantly decreases (Fig. 5), and at a distance of $x=4,842 \cdot 10^{-3}$ m temperature is only 75,00002 °C.

This applies in the case of permanent, and in the case of variable thermal characteristics.

When $\tau/\tau_c=1,0$ temperature system cell with distance from wall heating also significantly decreases, but at a greater distance from the previous case (Fig. 6), and at a distance of $x=2,2311 \cdot 10^{-2}$ m temperature is only 75.00001 °C. This concerns the case of constant thermal characteristics.

In the case of variable thermal characteristics temperature is also 75,00001 °C, but at a distance $x = 2,1672 \cdot 10^{-2}$ m.

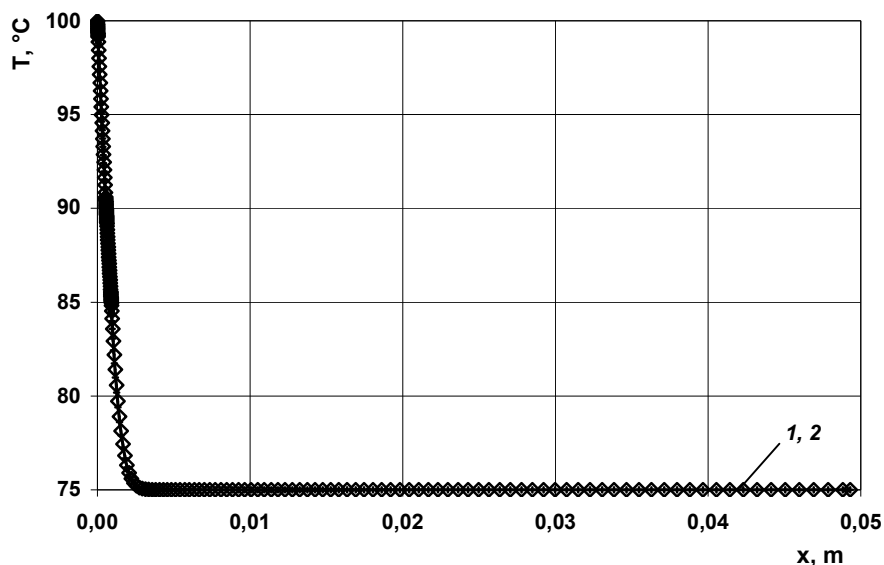

Fig. 5. The temperature distribution depending on the distance x from the heating tube inner surface to its symmetry axis (massecuite boiling relative time $\tau/\tau_c = 0,15$):

- 1 - $T_{x,cnst}$ (all thermal characteristics in all 7 regions is constant);
- 2 - $T_{x,var}$ (all thermal characteristics in all 7 regions is variable).

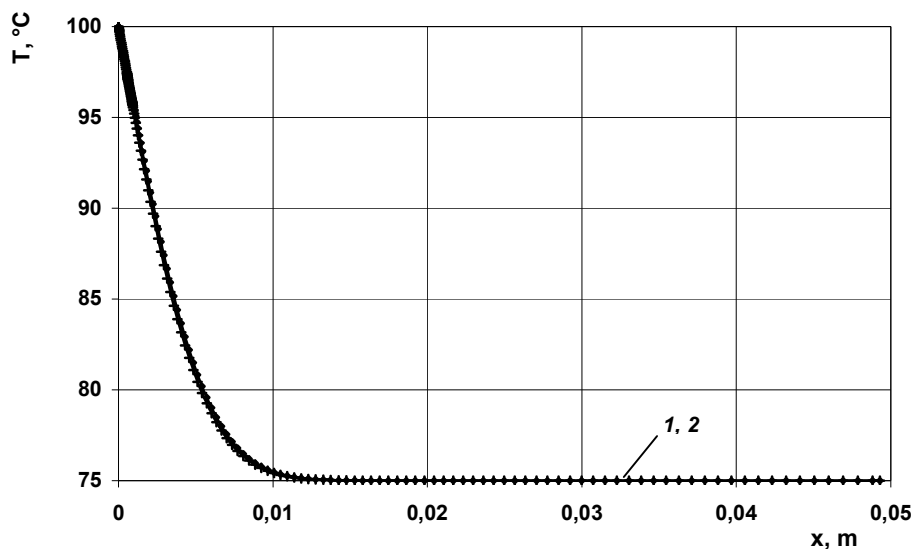

Fig. 6. The temperature distribution depending on the distance x from the heating tube inner surface to its symmetry axis

(massecuite boiling relative time $\tau/\tau_c = 1,0$):

- 1 - $T_{x,cnst}$ (all thermal characteristics in all 7 regions is constant);
- 2 - $T_{x,var}$ (all thermal characteristics in all 7 regions is variable).

Conclusions

The temperature distribution in the one-dimensional areas system are obtained.

Each of them is represents a certain cell (part of the cell) volume model cell " greater sugar crystal–sucrose solution greater crystal- smaller sugar crystal–sucrose solution smaller crystal" and massecuite that surrounds these cells.

Considered two cases of temperature distribution:

1) depending on the contact time $\tau_c(\tau/\tau_c)$ the whole system cells from the tube heating wall inner surface;

2) depending on the x distance from the heating tube inner surface to its symmetry axis.

In both cases, the calculations carried out $\tau/\tau_c = 0,15; 0,2; 0,3; 0,4; 0,5; 0,6; 0,7; 0,8; 0,9; 1,0$. This paper presents the results only for two cases relative boiling time: $\tau/\tau_c = 0,15$ and $\tau/\tau_c = 1,0$.

In each of these cases were considered constant or variable thermal characteristics for each area simultaneously.

The temperature distribution with lower values in all areas get taking into account variable thermal characteristics. The biggest differences in the system cells temperatures distribution at constant and variable thermal characteristics are less than 1%.

The results obtained the temperature distribution required in the future to solve the nonstationary diffusion mass transfer problem in system cells consisting of two sugar crystals, each of which is surrounded by a corresponding sucrose solution amount.

References

1. Tetiana Vasylenko, Sergii Vasylenko, Jeanna Sidneva, Vitalii Shutiuk (2014), Best available technology - innovative methodological framework efficiency of sugar production, *Ukrainian Food Journal*, 3(1), pp. 122-133.
2. Hugot E. (2014), *Handbook of Cane Sugar Engineering*, Elsevier Science.
3. Jenkins G.H. (2013), *Introduction to Cane Sugar Technology*, Elsevier Pub.
4. Jiahui Chen, Christine Nowakowski, Dan Green, Richard W. Hartel (2015), State behavior and crystal growth kinetics of sucrose and corn syrup mixtures, *Journal of Food Engineering*, 161, pp. 1-7.
5. Baikow V.E. (2013), *Manufacture and Refining of Raw Cane Sugar*, Elsevier.
6. Hugot E. (2014), 32 - Sugar Boiling, *Handbook of Cane Sugar Engineering*, Elsevier, pp. 459-528.
7. Lauret P., Boyer H., Gatina J.C. (2000), Hybrid modelling of a sugar boiling process, *Control Engineering Practice*, 8(3), pp. 299-310.
8. Alewijn W.F., Pieter Honig (2013), Chapter 9. Technology of sugar crystallization, *Crystallization*, Elsevier, pp. 318-370.
9. Semlali Aouragh Hassani, Saidi K., Bounahmidi T. (2001), Steady state modeling and simulation of an industrial sugar continuous crystallizer, *Computers & Chemical Engineering*, 25(9–10), pp. 1351-1370.
10. Thomas R. Gillett (2013), Chapter 6 - Control Methods And Equipment In Sugar Crystallization, *Crystallization*, Elsevier, pp. 224-249.
11. Kulinchenko V., Mironchuk V. (2012), *Promyshlennaya kristallizatsiya sakharistikh veshchestv*, NUPT, Kyiv.

12. Pogoriliy T. (2015) The distribution of temperatures in the sucrose solution–sugar crystal–sucrose solution–massecuite cells depending on the boiling sugar massecuite time, *Ukrainian Journal of Food Science*, 3(1), pp. 139–148.
13. Pogoriliy T. (2014), Obienna heometrychna model krystaliv tsukru v systemi komirok: krystaly tsukru-mizhkrystalni rozchyny sakharozy-parova bulbashka, *Naukovi pratsi NUKHT*, 20(5), pp. 141–151.
14. Pogoriliy T. (2014), Obienna heometrychna model mizhkrystalnoho rozchynu sakharozy v systemi komirok krystaly tsukru-mizhkrystalni rozchyny sakharozy-parova bulbashka, *Naukovi pratsi NUKHT*, 21(2), pp. 139–150.
15. Pogoriliy T., Mironchuk V. (2012), Mathematical modeling of recrystallization based on analytical solutions of non-stationary heat conduction problems in two-dimensional case for rectangular areas with heterogeneous (continuous and discontinuous on one side) boundary conditions and inhomogeneous initial conditions, *Abstracts and posts XIV Minsk International Forum on heat and Mass Transfer, 10-13 September, Vol. 1, Part 2, Minsk Institute of Heat and Mass Transfer them. A. Lykov NASB*, pp 761-764.
16. Eymard R. Gallouët, T. R. Herbin R. (2000), *The finite volume method Handbook of Numerical Analysis*, VII, pp. 713–1020.
17. LeVeque, Randall (2002), *Finite Volume Methods for Hyperbolic Problems*, Cambridge University Press.

Influence of cobalt stearate on destabilization of high-pressure polyethylene

Anastasiia Klieshchova, Arcadiy Pietuhov

National technical university of Ukraine "Kyiv Polytechnic Institute", Kyiv, Ukraine

Abstract

Keywords:

Self-destructive
Film
Polyethylene
Stearate
Cobalt
Timer

Article history:

Received 10.11.2015
Received in revised
form 12.12.2015
Accepted 24.12.2015

Corresponding author:

Anastasiia
Klieshchova
E-mail:
anastasiyakl@ukr.net

Introduction. The main purpose of research is to provide a timer-based polymer composition of high pressure polyethylene and cobalt stearate, which starts self-destruction through a certain period of time and can be used in the production of mini-packets for packing food products in supermarkets and further reduce environmental pollution.

Materials and methods. To determine the technological parameters processing of the compositions were performed thermomechanical and differential thermal analysis of cobalt stearate. To assess the destabilizing impact of cobalt stearate in the mixture held in the timer determination shrinkage conditional strength and elongation, getting dry residue by dissolving in xylene and water absorption. Infrared spectroscopy was used to assess the destabilizing effect on the molecular level.

Results and discussion. In determining the properties of cobalt stearate the thermomechanical curve confirmed by the plateau crossing from the pseudo-crystalline to the amorphous state. Analysis was conducted with next parameters: starting temperature measuring 16.8° C, weighed material - 24.1 mg, the sensitivity of apparatus - 20mg, rising of temperature 10 ° / min, weight loss after full cooling oven 85.5 %, the decomposition start temperature - 200°.

The optimal concentration is area of 3% in which the shrinkage of film sample was 46%, the value of the conventional longitudinal strength decreases after 3 months of exposure, corresponding to the climate zone of central Ukraine. After dissolving samples in xylene percentage of lost mass was 99.74%, which is a comparative characteristic for assess the depth of degradation chains. In determining of water absorption, the maximum exposure available for next investigation is 8 hours, at which water absorption is 21.4%. Infrared spectroscopy with increasing irradiation time gives the highest rate of ketone groups formation (in the range 1710-1725 cm^{-1}), alcoholic groups (1150 cm^{-1}) and a significant increase in the amount of water adsorption (3360 cm^{-1}) at a concentration of cobalt stearate within 3%, which also demonstrates depth of chains degradation on molecular level.

Conclusion. The timer-based polymer composition based on high-pressure polyethylene and cobalt stearate is designed with maximum efficiency in the area of 3%, proved its effectiveness and efficiency.

Introduction

The disposal of trash is a problem confronting our society [1]. Our available landfills are becoming exhausted. While polymers compose only about 8% by weight (20% by volume) of landfills [2], there is much focus on polymer accumulation because of their high visibility [3]. Recycling is one of the most important actions currently available to reduce these impacts and represents one of the most dynamic areas in the plastics industry today [4]. But recycling requires additional financial investments, moreover, to gather footage for a film packaging recycling extremely difficult. The article considers specifically film packaging materials for packing food and nonfood products, the most common of them - mini-packages for supermarkets. Therefore, the main goal is to create efficient polymer compositions based on high-pressure polyethylene and cobalt stearate, which is influenced by environmental factors (UV radiation, temperature, humidity) would break down after a specified period of time and not be a threat for environment.

Materials and methods

To determine the technological parameters processing of the compositions were performed thermomechanical and differential thermal analysis of cobalt stearate. To assess the destabilizing impact of cobalt stearate in the mixture held in the timer determination shrinkage conditional strength and elongation, getting dry residue by dissolving in xylene and water absorption. Infrared spectroscopy was used to assess the destabilizing effect on the molecular level.

Compositions. Compositions, used for getting samples are presented below (Table 1).

Table 1

Compositions used for samples

Component	Concentration C, %					
	1	2	3	4	5	6
LDPE 15803-020	100	99,9	99,5	99	97	95
Cobalt stearate	0	0,1	0,5	1	3	5

Getting of film samples. The hopper is filled by prepared composition comprising of high pressure polyethylene stamps 15803-020 and cobalt stearate. Preparation of the composition of dry components was conducted immediately before loading into the extruder to avoid excessive moisture environment and stratification. Samples were got by hot-melt extrusion [6], [7].

Firstly, preparation of composition was planed by method of dressing polyethylene granules and powdering them by cobalt stearate [11]. But after research, it became clear that because of relatively low compared to the polyethylene melting point of cobalt stearate serves as dressing himself, that is an additional component that would carry out the same function, such as paraffin or stearin simply not needed [8]. In addition, the additional component would increase the content of low molecular weight fraction, ie, reduced density to melt.

By varying the concentration of cobalt stearate received film with different its containing, ranging from 0 to 5% in polymer matrix.

Formation of the film is due to air supply, cooling intensity and speed of pulling rolls receiver.

Main specifications of installation:

The diameter of the worm, mm - 90

Rim Diameter, mm - 220

Dorn diameter, mm - 75

The size of the gap forming, mm - 1

The extent and degree of stretching blow are important parameters of the formation process, since their change can be obtained isotropic and anisotropic film, improve physical and mechanical properties of the film.

Table 2
Technological parameters of the process of obtaining blown film based on LDPE compositions

Compositions Parameters	Values				
	1	2	3	4	5
Temperature, °C:					
Loading zone	60				
First worm zone	120				
Second worm zone	160				
Circular zone	180				
Head	180				
Rotational speed of worm n, turn/min	15				
Tension on anchor, V	220				
Current strength worm drive, A	19	15	17	17	18
Productivity G, kg/h	7,78				
Admission speed film V, m/min	2,8				
The width of sleeve, mm (with an allowance,%)	235 ± 2	280 ± 2	235 ± 5	230 ± 5	230 ± 5
Blow degree, %	179	194	191	191	191

Periods of exposure. Based on data from NASA, the average intensity of irradiation latitude in which the Ukraine is 3,2 kW / day.

Average radiation intensity is:

$$3,2 \cdot 1000 \cdot 365 = 1168000W / year$$

Just as in the lab are available two lamps, 400W and 1000W intensity calculation is provided for both of them.

Lamp intensity 400W, imitates UV-radiation in the environment for 121,67 hours.

To simulate the exposure duration of month it will need 10h:

$$\frac{121,67 \cdot 30}{365} = 10h$$

Therefore, selected for the study intervals 1,2,3,4,5 months of this lamp imitates 10, 20, 30, 40 and 50 hours of exposure.

Based on the fact that the lamp of 1000W intensity is 2,5 times stronger, it was decided to use it. This lamp simulates intervals 1,2,3,4,5 months at 4, 8,12, 16 and 20 hours exposure equivalent climate zone of central Ukraine. Thus, the characteristics of the film used to package introduced mandatory property - degradation term.

Results and discussion

The impact of cobalt stearate on destruction of polyethylene macro – chains. The feasibility of using it except prevalence (widely used in rubber, tire production) and economic accessibility as a catalyst for action photoaging.

Under the influence of UV-rays and provide additional energy, the least strong link ~Co - O~ rushes and formed active macro-radical chain begins to break down polyethylene.

In this process is a photochemical degradation (photolysis) caused by light and caused cobalt stearate [9]. During photolysis, takes place not only breaking apart chemical bonds but also stitching, double bonds and formation of free radicals. The process is characterized by the quantum yield gaps chain (number of breaks per absorbed quantum of light), which for various polymers is in the range of 10^{-4} - 10^{-1} . Because of the high concentration of free radicals in relatively small areas, the destruction is accompanied stitching macromolecules, sometimes above the prevailing destruction.

The first stage is formation of macro-radical. In the case of cobalt stearate, stearin anion pulls over the electron density and thereby develops the double bond thus formed macro-radical.

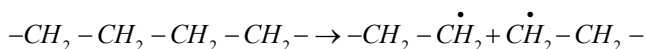

Further, the same processes as in the thermal destruction can proceed in the polymer. Since breaking the chain already held, begins its further growth:

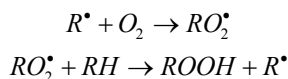

In addition, the influence of RO^\bullet -radical can also be described by the following mechanism:

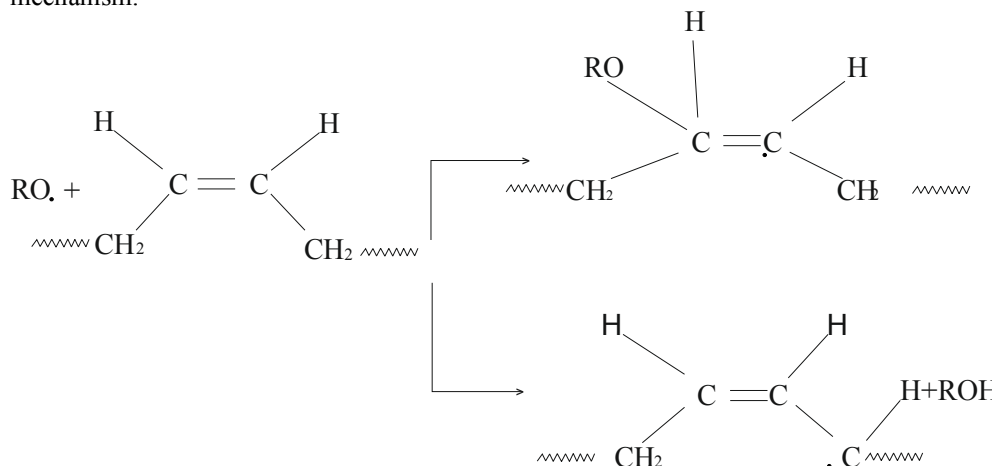

In parallel form macromolecular compounds. RO^\bullet -radicals can further decompose scheme that is below.

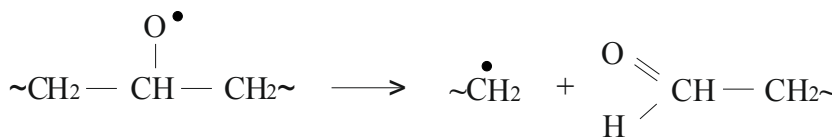

Aldehyde group, continue being oxidized:

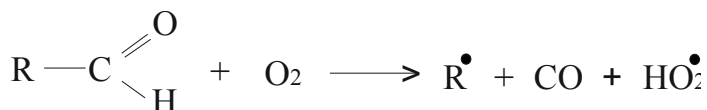

The thermo-mechanical and differential thermal analysis of samples. In determining the properties of cobalt stearate by differential thermal method the thermomechanical curve confirmed by the plateau crossing from the pseudo-crystalline to the amorphous state. In view of the state of solid cobalt stearate it suggests about the crystal structure as well as broken, when force is applied, having a straight edge chipping and shine. Upon reaching a plateau, it is clearly evident that the material is amorphous. By analysis which was conducted with next parameters: starting temperature measuring 16.8° C, weighed material - 24.1 mg, the sensitivity of apparatus - 20mg, rising of temperature 10 ° / min, weight loss after full cooling oven 85.5 %. The curve shows exo-effect of sample with increasing temperature. Up to 200° C temperature observed slow "soft" growth of curve corresponding to undermine the falling mass. This trend is explained by the foaming material through the device because of the high sensitivity captures the seeming increase in mass of the sample. At 200° C the beginning there plateau, which at the value of 250° C passes in a fairly sharp rise in the curve is falling value of the mass. This temperature clearly shows that sample starts to burn and decompose. In the range of 300° C-500° C is thermal expansion of the material. The highest peak accounted on 450° C, which corresponds to the point in which the process takes place with the greatest activity. Waves on the curve in the temperature range 550° C-950° C can be explained in two points. The first is high sensitivity equipment that captures noises. The second is the possibility of moving to another sample verifiable modification.

Determination of shrinkage. Higher concentrations of cobalt stearate reduces the shrinkage. This phenomenon can be explained by increased yield strength, as evidenced by the fall amperage anchored motor. Since the viscosity dropped, then the molecules forming the sleeve easier slipped relative to each other and to a lesser degree there was swing the sectors degree of orientation is reduced as the confirmed results of the study on shrinkage. Growth values the importance shrinkage 5% * explains the presence of quite large particles of cobalt stearate, visible to the naked eye, which are centers of concentration of stress.

Determination of relative strength and elongation. Research carried out in each group concentrations of cobalt stearate and over time during irradiation. The starting point was to compare the strength characteristics for each value of the concentration of cobalt stearate to radiation. The lowest values observed at concentrations of 0.5% and is accompanied by a sharp drop in viscosity.

That is, changing the viscosity and thermal characteristics. At constant cooling conditions, the drop of viscosity caused displacement crystallization line. Since the distance

to the line of crystallization decreased, it resulted in underdevelopment crystallite structure, which led to a lower value of relative strength compared to other models.

In each of the exposure period is compared between samples with different concentrations of cobalt stearate. A comparison of the graphs shows that the most destructive action endowed is area of concentration 3%. This concentration is optimal. Optimum results from the fact that up to 3% cobalt stearate in the composition is escalating destructive properties.

As said before, the samples obtained by the same parameters with the concentration of 5% are not accepted for investigation, because so much of cobalt stearate gives a high volume of bubbles. This model does not reflect the real picture of strength characteristics.

Instead, the samples with the same concentration of cobalt stearate, but produced at lower turns were used. With increasing exposure time, sample with concentration of cobalt stearate 5% yield samples at 3%, because firstly, for such a large number of accumulated radicals, as in samples with a concentration of 5%, beginning the process of crosslinking, and secondly, visible to the naked eye stearate cobalt particles in the thick film perform function of reinforcing the principle of reinforcing particles.

Determination dry residue dissolving in xylene. Film samples with concentrations of cobalt stearate 0.1, 0.5, 1, 3, and 5% were obtained following dependence.

The graph in Figure 1 clearly shows that over time, the strongest fall observed in the weight value once the concentration of cobalt stearate 3%, due to the most intense destruction of macro-chains for the concentration.

There is a complete dissolution of the sample with the concentration of cobalt stearate 3%, indicating the deepest in this number of samples degradation of the polymer chains.

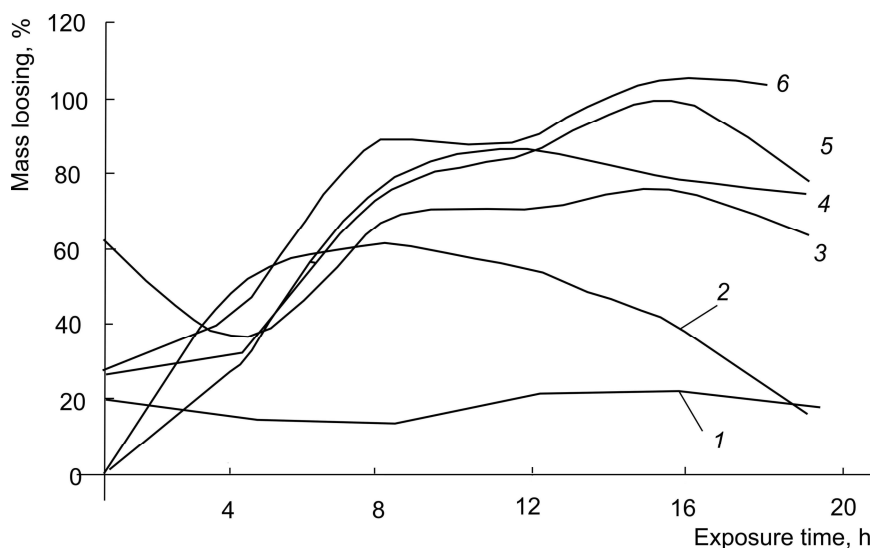

Fig. 1. Dependence of weight loss in dissolving in xylene for pure PE and cobalt stearate contented. Concentrations are 1 – 0%, 2 – 0,1%, 3 – 0,5%, 4 – 1%, 5 – 3% and 6 – 5%.

Determination of water absorption. For comparison, in each row exposure time, studied a sample of pure PE films.

Speaking about the most effective concentration of cobalt stearate 3%, the graph presented in Figure 2 shows that in times of irradiation 8-16 hours, water absorption is reduced, as well as in most of the samples which could be explained by the phenomenon of crosslinking, which also initialized UV-radiation [12],[13]. This analysis allowed to determine not only the amount of water absorbed, indicating the degree of degradation of the polymer chains, but also clearly see the influence of moisture in the environment to your samples. Since moisture is an additional natural factor and affect sent to landfill mini package with UV radiation, no harm will see qualitative changes in the samples [10].

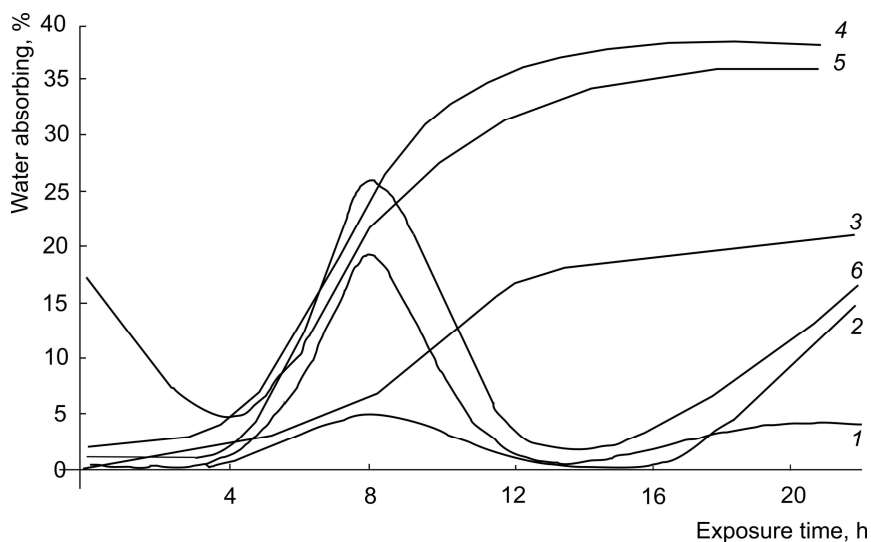

Fig. 2. The dependence of water absorption of the exposure time for pure PE and cobalt stearate contented. Concentrations are 1 – 0%, 2- 0,1%, 3 – 0,5%, 4 – 1%, 5 – 3% and 6 – 5%.

After the moisturising, some samples were not possible to weigh because of the fact that they are almost completely dispersed or dissolved. The most effective concentration is 3%.

Infrared spectroscopy. Figure 3 shows the infrared spectrum of the film of pure PE. It is characterized by peaks in the range of 2930 cm^{-1} to 2840 cm^{-1} , corresponding to oscillations of group CH_2 (assym) and heart failure, as well as peaks in 1460 cm^{-1} (δCH_2), 1365 cm^{-1} (δCH_2) and 710 cm^{-1} (γCH_2).

Significant changes in the internal structure of samples with a concentration of 3% cobalt stearate can be seen already after 4 hours of irradiation under UV. There was a big peak in the area of $1710\text{--}1725\text{ cm}^{-1}$, indicating the formation of ketone groups. Ketone groups show that the dissolved polymer chain really started to attach oxygen. In addition, the area of 1150 cm^{-1} peak seen characterizing the alcohol group C-O, which also shows the lipid chains with torn ligaments. As a result of shorter chains, increased water sorption content in the sample.

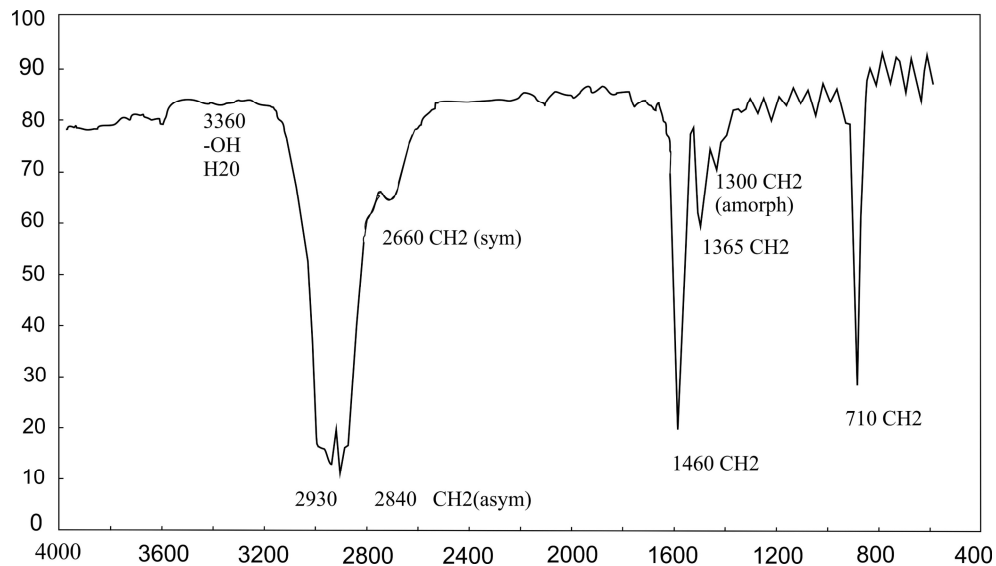

Fig. 3. Infrared spectrum of pure PE films

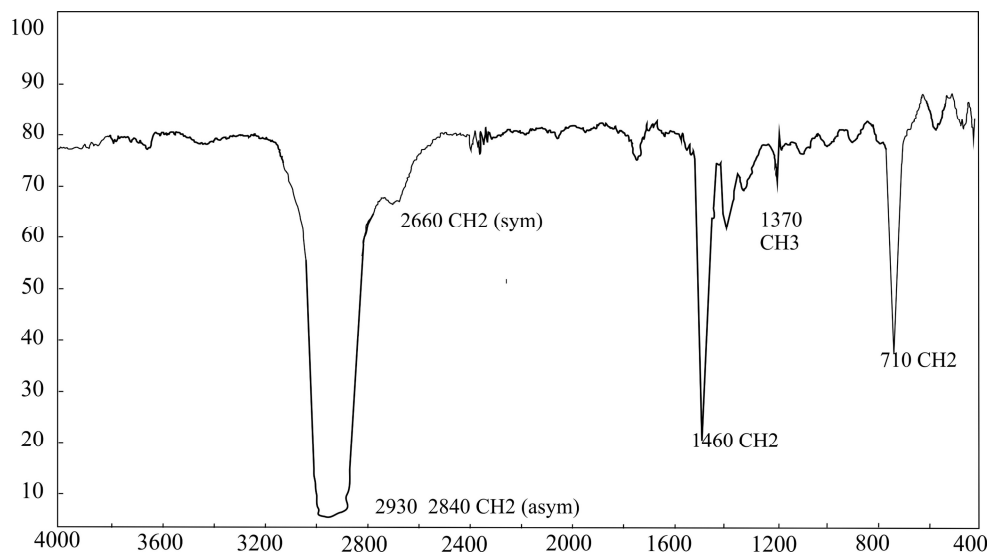

Fig. 4. The infrared spectrum of the film containing 0.1% cobalt stearate without irradiation

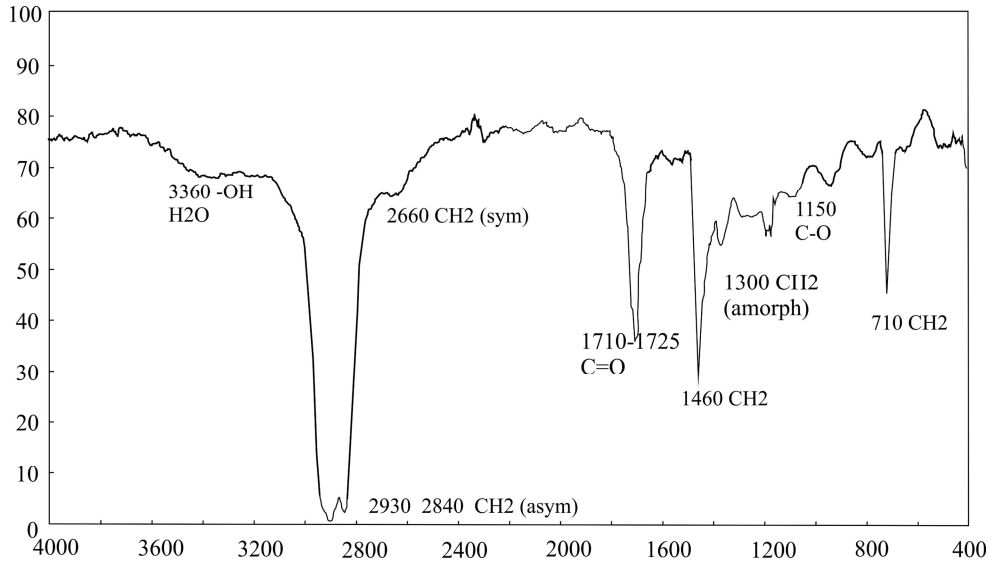

Fig. 5. The infrared spectrum of the film containing 3% cobalt stearate after 4 hours of exposure

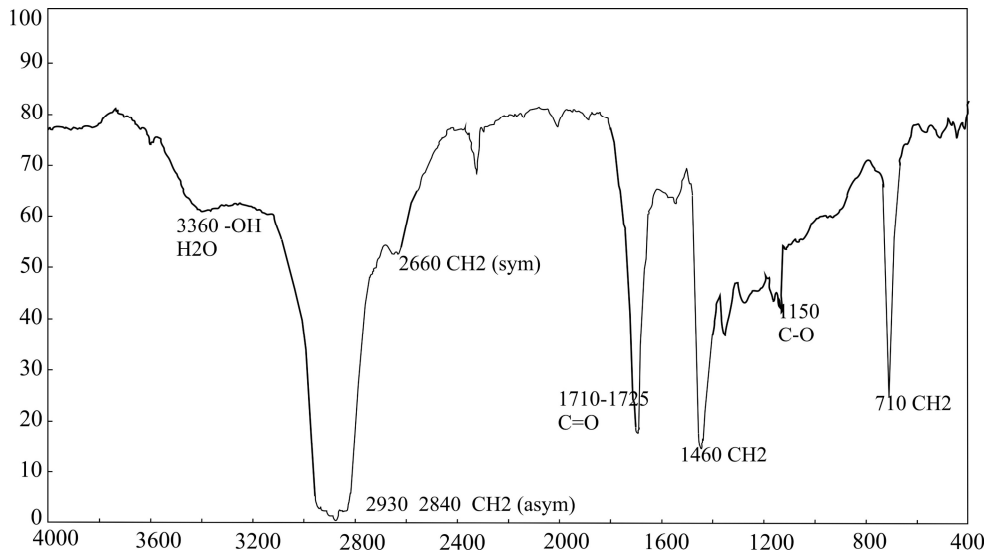

Fig. 6. infrared film containing 3% cobalt stearate after 8 hours irradiation

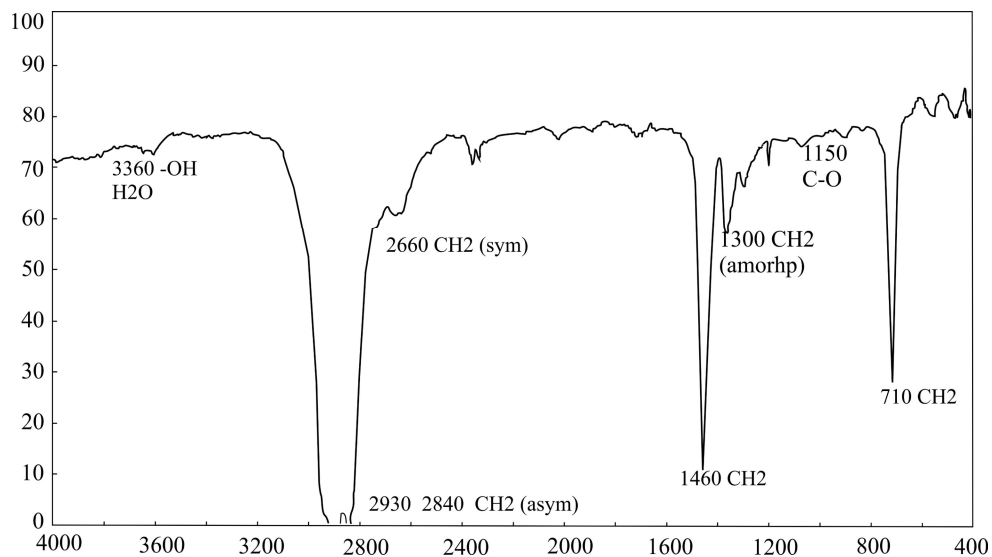

Fig. 7. The infrared spectrum of pure PE films after irradiation for 8 hours

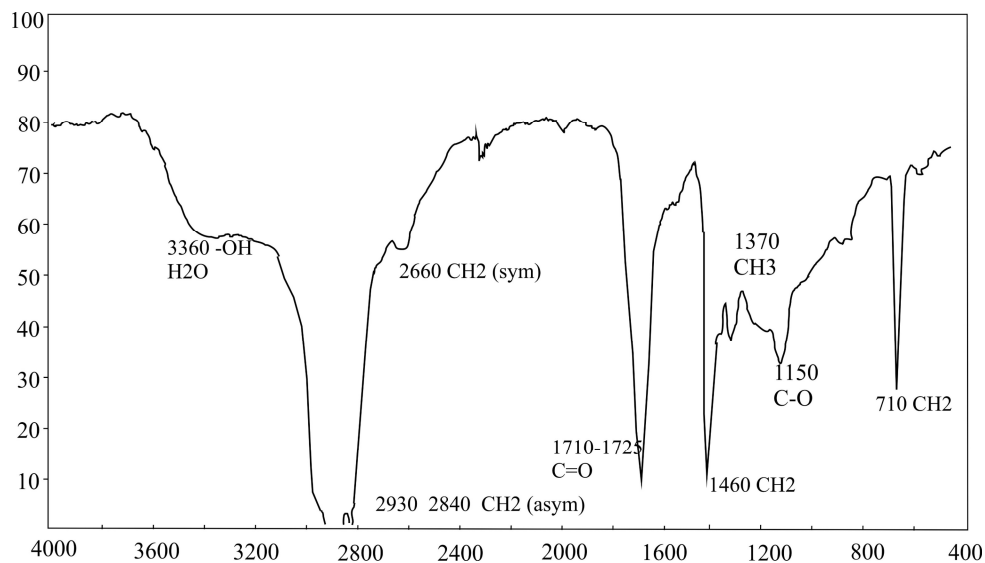

Fig. 8. infrared film containing 3% cobalt stearate after 12 hours of exposure

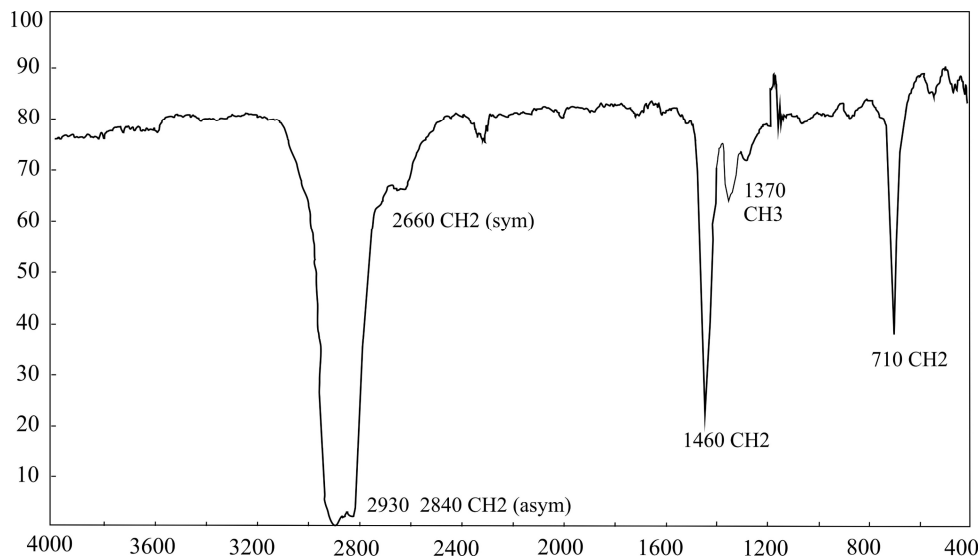

Fig. 9. The infrared spectrum of pure PE films after 12 hours of exposure

Comparing film samples without filling stearate cobalt and filled with cobalt stearate with concentration of 3% after exposure for 12 hours, conclusions can be done. Over time, deeper 1710-1725 cm^{-1} peak in the area, indicating that the increase in ketone C = O groups and deepening oxidizing of chains. In addition, the peak in 1150 cm^{-1} zone was deepened in, that of alcohol, which is oxidized one end of the chain, accumulate over time.

Data of Infrared spectroscopy clearly show that cobalt stearate percentage in area of 3% actually works as destabilizing additive that promotes oxidation and degradation of polymer marco-chains.

Conclusion

The timer-based composition based LDPE and cobalt stearate at maximum efficiency in the neighborhood of 3% concentration is developed, proved its effectiveness and efficiency. In this part of the composition there is a profound degradation of the polymer chains that proved complex of analyzes, which simulated use of the product for the purpose of the film, and after that - the impact of environmental factors.

References

1. Anonymous (1990), *Modern Plastics*, Special Suppl, April.
2. Exxon Chemical (1991), *Plastics and the Solid Waste Issue*, Exxon Chemical Co.
3. Richard S. Stein (1992), *Polymer recycling: Opportunities and limitations, Colloquium Paper*, 89, pp. 835-838.

4. Jefferson Hopewell, Robert Dvorak, Edward Kosior (2009), *Plastics recycling: challenges and opportunities*, Philos Trans R Soc Lond B Biol Sci.
5. Information sources include polymer manufacturers' data; "Effects of Radiation on Polymers & Elastomers," NASA/Jet Propulsion Laboratories, 1988; Skeins and Williams, "Ionizing Radiation Effect on Selected Biomedical Polymers"; Kiang, "Effect of Gamma Irradiation on Elastomeric Closures," Technical report 16, PDA, 1992; Ley, "The Effects of Irradiation on Packaging Materials," 1976.
6. Jörg Breitenbach (2002), Melt extrusion: from process to drug delivery technology. *European Journal of Pharmaceutics and Biopharmaceutics*, 54, pp. 107-117.
7. John R. Wagner Jr., Eldridge M. Mount III, Harold F. Giles Jr. (2014), 1 – Extrusion Process. *Extrusion (Second Edition)*, pp. 3–11.
8. Adela Kalivoda, Matthias Fischbach, Peter Kleinebudde (2012), Application of mixtures of polymeric carriers for dissolution enhancement of fenofibrate using hot-melt extrusion, *International Journal of Pharmaceutics*, 429(1–2), pp. 58–68.
9. Chao Zhang, Natalie Waksanski, Vincent M. Wheeler, Ernian Pan, Ross E. Larsen (2015), The effect of photodegradation on effective properties of polymeric thin films: A micromechanical homogenization approach, *International Journal of Engineering Science*, 94, pp. 1-22.
10. K.A.M. dos Santos, P.A.Z. Suarez, J.C. Rubim (2005), Photo-degradation of synthetic and natural polyisoprenes at specific UV radiations, *Polymer Degradation and Stability*, 90(1), pp. 34-43.
11. Michael Niaounakis (2015), Chapter 6 – Powdering, *Biopolymers: Processing and Products*, pp. 263-276.
12. Michael Tolinski (2015), 15 – Cross-Linking, *Additives for Polyolefins (Second Edition)*, pp. 159-162.
13. Luigi Costa, Pierangiola Bracco (2015), 26 – Mechanisms of Cross-Linking, Oxidative Degradation, and Stabilization of UHMWPE, *UHMWPE Biomaterials Handbook (Third Edition)*, pp. 467-487.

Buying dietary supplements and over the counter drugs in the Czech Republic

Tomáš Sadílek

University of Economics, Prague, Czech Republic

Abstract

Keywords:

Counter drug
Marketing
Buying
Dietary
Medicine

Article history:

Received 02.11.2015
Received in revised
form 18.12.2015
Accepted 24.12.2015

Corresponding author:

Tomáš Sadílek
E-mail:
tomas.sadilek@vse.cz

Introduction. The aim of this survey was to evaluate the consumers' behaviour of dietary supplements and over the counter drugs on the market in the Czech Republic and to define four main segments of customers. Group of pharmacy customers in the Czech city was interviewed to find out, how often they buy dietary supplements and over the counter drugs.

Materials and methods. Respondents came from a sample aged from 18 to 80 and most of respondents were rather higher educated. A method of research was structured questionnaire. Respondents were asked prior drugstores.

Results and discussion. There is a need for consumers' education on reliable use of herbal medicines and herbal dietary supplements, in order to improve their awareness of the limits of herbal remedies safety and potential risks of their combination with drugs. The most important findings are, in the Czech Republic 86 % of respondents buy dietary supplements and majority of responded consumers (64 %) believe its effect on health. Based on our research, four segments were defined, called as „caring“, „mistrustful“, „natural“ and „trustful“. „Caring“ customers are the most numerous (64 %) and buys the most painkillers, but spend almost the least amount of money (5.29 € per month for over the counter drugs and dietary supplements). „Natural“ customers have share of 14 % in the Czech population. This group buys mostly dietary supplements and other types of drugs. „Trustful“ buyers prefers medicines for flu and colds and for digestion. They have also the second highest payments for over the counter drugs and dietary supplements. „Mistrustful“ customers do not buy any over the counter drugs and dietary supplements.

Conclusion. This research builds on the existing literature on pharmaceutical marketing and gives comprehensive findings about Czech dietary supplements and over the counter drugs market.

Introduction

Dietary supplements are vitamins, minerals, amino acids, specific fatty acids, extracts and other substances with significant biological effect (by Act No. 110/1997 on food as amended by the Act No. 306/2000 Sb. § 2. letter i). These products are available in pharmacies, drugstores, groceries and are available without any prescription. Prior bringing them in the market, National Health Institute has to evaluate their health harmlessness. In contrast with pharmaceuticals, nobody evaluates their effectiveness [1].

Dietary supplements are also products which look very similar to pharmaceuticals, but this is only specific category of foodstuffs. It is concentrated source of vitamins and mineral substances or other substances with nutritional or physiological effect, contained in the foodstuff itself or in the combination of foodstuffs, intended for direct consumption in measured small unit quantities. Another goal of dietary supplements is to supplement the normal diet consumer level and positively affect his or her health.

In the Czech Republic dietary supplements are solved in the following legislative documents. Bill of Ministry of Health No. 225/2008 Sb. defines requirements for dietary supplements and food enrichment (amended by bill No. 352/2009 Sb – changes of recommended dose of some minerals and vitamins), where are listed allowed vitamins and mineral substances, their purity and maximum amounts per daily dose. Bill No. 352/2009 Sb. also presents a list of plants, which are prohibited for production of dietary supplements. Other documents which deal with dietary supplements are Act No. 110/1997 Sb., on food and tobacco products and Ordinance of European Parliament and European Council No. 1924/2006 on nutrition and health claims made on food labelling [2].

Literature review

Customer behaviour reflects the totality of their decisions regarding goods, services, activities and ideas, namely the acquisition, consumption and disposal of goods or services [4]. Customer behaviour is influenced by cultural, social and personal factors. Cultural factors are presented as the largest and broadest group and they include ethnicity, religion, racial group and social class. Social factors comprise family, reference groups, social role and position in society. Personal factors include age, occupation and lifestyle [5].

There are two approaches to the analysis of customers: quantitative and qualitative. Qualitative analysis may be performed by the black box model, which is based on stimulus and response. Advertising can be one of the stimuli. A marketer looks for the reasons why a customer responded. Another qualitative analysis is based on the decision-making process, which includes recognising the problem, searching for information, evaluating alternatives, purchase decision and behaviour after purchase.

Customer behaviour is an ongoing process. This process does not end with purchase and payment. It involves the handling of products, repeat purchases and satisfied or unsatisfied behaviour [6].

Customer behaviour involves many different actors. Each of them has a different role. Each role may be performed by one person or one person can perform many roles. The purchaser and user of a product may not be the same person. Other roles include informant, decider and influencer [6].

Customer behaviour comprises five elements. Each of these elements influences marketing strategies and tactics. In models of customer behaviour, many questions describe behaviour accurately, such as what a customer buys and when and where a customer buys

it. The actors in a decision-making process have many roles: information gatherer, influencer, decider, purchaser and user. The decision-making process takes place at a certain time

Advertising can play an important role in a decision-making process, especially informing and influencing. Advertising informs about new and existing medicaments, and an advertisement may have different forms such as television and radio advertising, advertising on the Internet, in pharmacies or in magazines. This is valid for the medicaments freely available.

These factors may affect the Decision making process. Purchasing decision-making process has several phases. The phases are follows: recognition, information search, alternative evaluation and selection, outlet selection and purchase, and post-purchase processes. There are certain factors that play a role at each phase [7].

Consumer behaviour is influenced by many factors. Customers are influenced by a risk of buying, innovativeness in the adoption of new products, variety in purchase, retail facilities or window displays, and interviews with other persons about purchases [9].

Internal and external factors affect customers. These facts are transferred to decision-making process by affected customers. Individuals develop self-concepts and subsequent lifestyles based on a variety of internal and external influences. These self-concepts and lifestyles produce needs and desires. It affects the decision-making process, as is indicated in [7]. The decision-making process affects internal and external factors in the form of experiences and acquisitions.

The internal factors are determined by customers. Hawkins et al. divide these factors into seven groups – perception, learning, memory, motivation, attitudes, personality, and emotions [7].

The perception is a process by which individuals receive and assign interest to stimuli. Stimuli are gathered through the five senses – sight, hearing, touch, taste and smell. Perception of object results from the interaction of two types of factors: stimulus factors (size, colour) and individual factors (including sensory processes, experience, basic motivations and expirations of individual). Learning is change in the content and structure of long-term memory; it is the result of information processing [8].

Memory can be divided into short-term memory and long-term memory. Each individual has short-term memory (working memory), it is a portion of total memory that is currently activated or in use and long-term memory, and it is that portion of totally memory devoted to permanent information storage [7].

Sort-term memory has a limited capacity to store information and sensations and long-term memory is viewed as an unlimited, permanent storage.

Jamal et al. (2006) describe motivation based on two types of psychosocial needs: personal and social. Motivation is the reason for behaviour, e.g. purchase). The reasons may be personal or social. The personal motives include the needs for role-playing, self-gratification, and diversion, learning about new things, physical activity, and sensory stimulation.

The social motives include the communication with others, group attractions, status and authority, and pleasure in bargaining.

Attitudes are described by Hawkins et al. as an enduring organization of motivational, emotional, perceptual and cognitive processes with respect to some aspect of the environment. The internal factors are also: personality (characteristics of person), and emotions (relatively uncontrolled feeling that affect behaviour) [7].

Hawkins et al. divide external factors into seven groups – culture, subculture, demographic characteristic, social status, reference groups, family, and marketing activities [7].

Culture can be defined as the values, beliefs, preferences and tastes handed down from one generation to the next. Every marketer need to understand their role in consumer decision making.

Marketing strategies have to be varied in each area. This is due to the differences in cultures in different areas [8].

Hawkins et al. define subculture, demographic characteristic, and family as follows. Subculture is a segment of a larger culture whose member shares the distinguishing values and patterns of behaviour. Subculture produces unique market behaviours. Members of subculture are part of the larger culture. Demographic characteristic includes the number, education, age, income, occupation and location of individuals in society. Family has a role in teaching children how to consume and household decision making [7].

Social status and reference groups are defined as follows. Social status – consumers belong to a number of social groups. Differences in group status and roles can affect buying behaviour. Status is the relative position of any individual member in a group [8].

Roles define behaviour that members of a group expect of individuals who hold specific positions within that group. Groups define formal roles and others. Reference groups influence person's behaviour by the value structures and standards. Children are especially vulnerable to the influence of reference groups. They base their buying decisions on outside forces (television, internet, fashion icon, singer, actor and other celebrity, friends). Reference groups have a few members act – opinion leaders. They share their experience and opinions about new products [8].

Marketing activities is concentrated in product strategy, price strategy, place strategy and promotion strategy. Marketing communication has an important role in the decision making process.

It can be realized using advertising, promotion, public relations, direct marketing and personal selling.

Purchasing behaviour of customers can be divided into two categories. Customers ask themselves two types of questions – (1) whether the customers buy products, (2) which products the customer buys (if there are substitutes). Consumers have a difficult situation in deciding because the number of variants available as the market grows. There is the problem of how people choose from among a large number of variants. People make decisions based with the aim of maximizing their total benefit in relation to their budget line.

In 1999, pharmaceutical companies spent 1.8 billion dollars on direct-to-consumer advertising compared with less than 300 million dollars in 1994 [10]. US research on prescription drugs has shown that customers are increasingly exposed to direct-to-consumer advertisements. The results show that doctors are increasingly confronted with patients who ask questions or who make suggestions based on these advertisements [10].

Pharmaceutical marketing influences customers very intensively [16] as well as culture [17]. Another interesting findings about relations between dietary supplements consumption and their sweetness presents [18]. Conclusions about determinants of dietary supplement use depicts [19] and [20].

Analysis of Czech market of drugs and dietary supplements

Drugs and dietary supplements can be described in the following way. Expenditures of health insurance companies on prescription drugs have a growing trend (values are not adjusted for inflation). Expenditure of health insurance companies on prescription drugs since 2008 increased by 10.25% (adjusted for inflation only 1.44%) and the average cost of a prescription medication given to the insured of 8.67%. (Adjusted for inflation, however, we get a negative value for cost reductions of -0.12% for the years 2008 to 2012) [3].

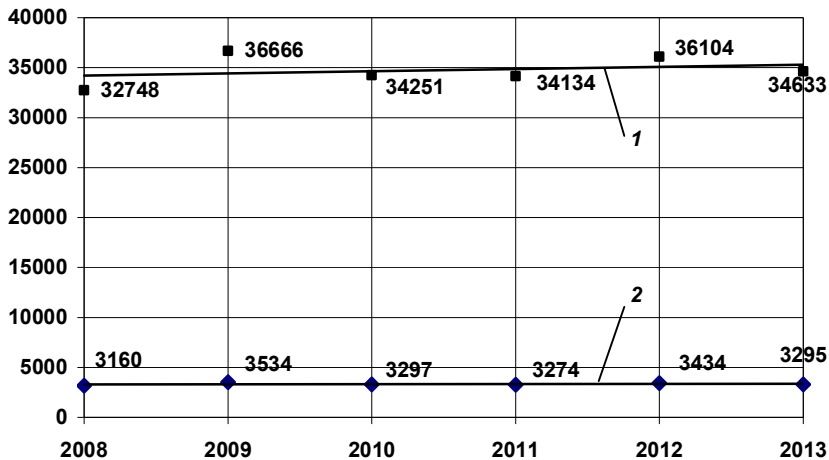

Figure 1. Structure of drugs sales in 2006-2013:

- 1 – Health insurance expenditures for prescription drugs
- 2 – Average costs for prescription drugs per policyholder

Source: own elaboration based on [12], [14]

Development of the volume of distributed drugs. Compared with other European countries shows that the Czech Republic has a lower than average consumption of drugs both in absolute terms and in purchasing power parity, the lower values reached Estonia, Poland and Denmark. Interesting is not finding that the Nordic countries (of the countries plus Norway and Finland the consumption of drugs, despite climatic conditions, rather lower than necessary to Germany, France or Belgium. Remarkable is also the result of Slovakia, which has purchasing power parity consumption higher 44%.

The average price of drugs for the past 11 years has risen by 125%, but adjusted for inflation, we conclude that the average price for drugs from 2001 to 2012 actually fell to 95.9%.

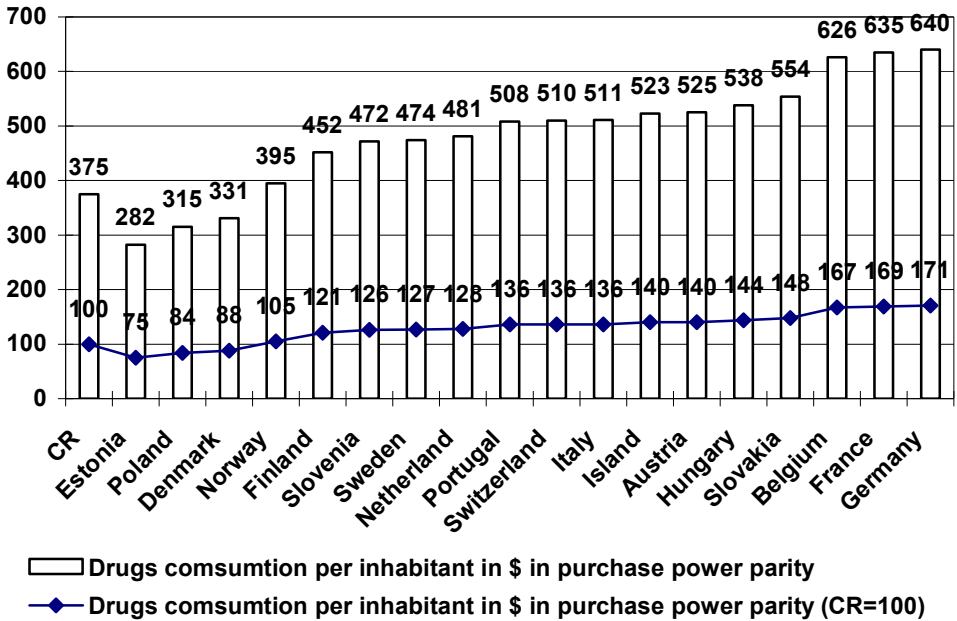

Figure 2. Development of drug consumption per capita in purchasing power parity in 2012
Source: own elaboration based on [3]

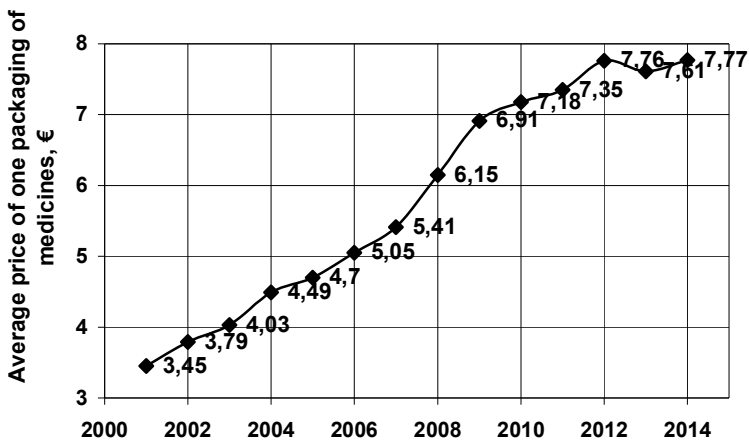

Figure 3. Average prices of one packet of drugs in €
Source: own elaboration based on [15]

Materials and methods

Relations between information about over the counter drugs and dietary supplements and their real consumption are illustrated by research made in February 2013 in Czech city with 12,000 inhabitants, frequently visited by tourists with the sample of pharmacy visitors. Respondents came from a sample aged from 18 to 80 and most of respondents were rather higher educated. A method of research was structured questionnaire. Respondents were asked prior drugstores.

Structured questionnaire with sixteen questions has been used for personal interviewing.

Table 1

Sample structure (n = 125)
Source: own elaboration

Sex	Male	20.0%	Education	Primary school	9.6%
	Female	80.0%		Secondary school	60.8
Age	18 - 25	35.2%		University	29.6%
	26 - 35	12.8%	Social status	Employed	45.6%
	36 - 45	20.0%		Unemployed	6.4%
	46 - 55	20.0%		Entrepreneur	8.0%
	56 - 65	10.4%		Student	32.0%
	66 and more	1.6%		Pensioner	8.0%

The obtained data were analysed with use of factor analysis using Varimax rotation and cluster analysis were created by four mutually heterogeneous segments. Market segmentation is the process of distribution of customers within each market into distinct groups. Whose members share a similar level of interest in the same or a comparable set of needs that can be satisfied certain market supply [11].

Result and discussion

Individual frequency of purchase of medications and dietary supplements, and spending on them can be compared by each segment. These findings are presented in Table 2.

Table 2

Frequency of purchase of over the counter drugs and dietary supplements and expenses for them

Source: own elaboration

	Frequency of buying dietary supplements	Frequency of purchase of medicines for flu and colds	Frequency of buying painkillers	Frequency of buying drugs on the digestion	Frequency of purchase of other drugs	Average monthly expenses for medicines and dietary supplements
Caring 64 %	2.67	2.35	3.34	0.70	0.27	5.29 €
Distrustful 14 %	never	never	never	never	never	0 €
Natural 14 %	3.26	1.88	0.99	0.18	0.53	7.77 €
Trustful 8 %	1.4	3.4	2.4	0.8	never	7.22 €

Caring, who are also the most numerous segment, comprising 64% of respondents prefer natural products and health care is a priority for them. They believe that the use of drugs burdens the body. These customers are not characterized by extreme values in the purchase of over the counter drugs and dietary supplements fall more into the mainstream consumption. The only exceptions are medications to hurt (3.34 / year), which buy even more than three times more often than the natural segment of consumers.

Distrustful of the effects of dietary supplements do not believe supplements just pull the money and pharmaceutical products are harmful, according to them, which also reflects the fact that none of the monitored products not purchased. This segment as the table showed purchase no drug or dietary supplement.

For the segment of **natural**, health care is a priority, but despite a positive relationship with the natural healing products are essential medications is always in stock. This characteristic is also in their purchasing behaviour, which can confirm the high frequency of purchase of dietary supplements (3.26 / year) on one side and lowest frequencies buying drugs for flu and colds (1.88 / year), painkillers (0, 99 / year), and drugs for digestion (0.18 / year). Based on the presented data, we can say that a healthy lifestyle has a positive effect on the morbidity of consumers and therefore to purchase drugs.

Trustful believe that pharmaceutical products use is not harmful, and this intention should be reflected in their purchasing behaviour. This group of customers buys carries out the highest number of sales in the category of drugs for flu and colds (3.4 / year) and ingesting drugs (0.8 / year). The table also shows that two maximum values of purchases are done by this group.

Conclusion

Czech market of over the counter drugs and dietary supplements have had since 2008 rising trend in health expenditures for prescription drugs but average costs for prescription drugs per policyholder fell down in 2010, 2011 and in 2013. Comparing the volume of distributed medicines in the Czech Republic with other European Union countries, Czech Republic has under average consumption and only Estonia, Poland and Denmark have lower amount distributed medicines. In total, average prices of one packet of drugs since 2001 till 2014 have doubled.

Based on our research, in the Czech Republic we can define four types of over the counter drugs and dietary supplements buyers. The most numerous (64 %) are customers called „caring“ who buys the most painkillers, but spend almost the least amount of money (5.29 € per month for over the counter drugs and dietary supplements). The second numerous group of customers are „natural“ with them share of 14 % in the Czech population. This group buys mostly dietary supplements and other types of drugs. Group of „trustful“ buyers prefers medicines for flu and colds and for digestion. They have also the second highest payments for over the counter drugs and dietary supplements. The rest of respondents are „mistrustful“ customers, who do not buy any over the counter drugs and dietary supplements.

Acknowledgments. *The research was supported by grant F2/94/2015 “Analysis of quality labels utilization in the Czech food market and efficiency of campaigns supporting them” at Faculty of International Relations, University of Economics, Prague.*

References

1. Vlastníková V., Kubrycht L., Fialová D. (2009), Doplnky sportovní výživy ve stravě sportující mládeží, *Hygiena*, 54, pp. 88-91.
2. Hlúbik J., Hlúbik P. (2012), Doplnky stravy a jejich možnosti využití u některých degenerativních procesů. *Hygiena*, 57, pp. 68-71.
3. (2014), Health at a Glance: Europe 2014, Available at http://ec.europa.eu/health/reports/docs/health_glance_2014_en.pdf
4. Hoyer W.D., Macinnis D.J. (2007), *Consumer Behavior*, Houghton Mifflin, Boston.
5. Kotler P. (2003), *Marketing management*, Grada, Praha.
6. Solomon M. R. (2009), *Consumer behavior: buying, having, and being*, Pearson Prentice Hall, Upper Saddle River.
7. Hawkins D. I., Mothersbaugh D. L., Best R. J. (2007), *Consumer behavior: building marketing strategy*, McGraw-Hill/Irwin, New York.
8. Boone L. E., Kurtz D. L. (2012), *Contemporary Marketing. 15th edition*, South Western Educational Publishing, Mason.
9. Baumgartner H., Steenkamp J. E. M. (1996), Exploratory consumer buying behavior: Conceptualization and measurement, *International Journal of Research in Marketing*, 13(2), pp. 121- 137.
10. Woloshin S., Swartz L.M., Tremmel J., Welch H.G. (2001), Direct-to-consumer advertisements for prescription drugs: what are Americans being sold?, *Lancet*, pp. 1141–1146.

11. McDonald M., Dunbar I. (2012), *Market Segmentation: How to Do It and How to Profit from It*, John Wiley & Sons, Chichester.
12. (2014), *Evaluation of Supplies Distributed Medicals in 2014*, available at: <http://www.sukl.cz/hodnoceni-dodavek-distribuvanych-lecivych-pripravku-za-rok-4>
13. (2015), *Consumer price indices - inflation - time series*, available at: <http://www.iaso.org/iotf>
14. (2015), *Selected Demographic Data in the Czech Republic*, available at: https://www.czso.cz/documents/10180/20551237/32018115_0101.pdf/82ff508d-9727-46cc-bc13-6eed5b9e50a7?version=1.0
15. (2014), Health Insurance Corporations - Costs spent on Health Care by Types of Health Care, available at: www.uzis.cz/system/files/ai_2014_24.pdf
16. Mei-Ling W., Marjorie D. (2015), Do consumers perceive their doctors as influenced by pharmaceutical marketing communications?: A persuasion knowledge perspective, *International Journal of Pharmaceutical and Healthcare Marketing*, 9, pp. 330-348.
17. Williams J.D., Crockett D., Harrison R.L., Thomas K.D. (2012), The role of food culture and marketing activity in health disparities, *Preventive Medicine*, 55, pp. 382-386.
18. Methven L., Rahelu K., Economou N., Kinneavy L., Ladbrooke-Davis L., Kennedy O.B., Mottram D.S, Gosney M.A (2010), The effect of consumption volume on profile and liking of oral nutritional supplements of varied sweetness: Sequential profiling and boredom tests, *Food Quality and Preference*, 21, pp. 948-955.
19. Kofoed C.L.F., Christensen J., Dragsted L., Tjønneland A., Roswall N. (2015), Determinants of dietary supplement use - Healthy individuals use dietary supplements, *British Journal of Nutrition*, 113, pp. 1993-2000.
20. Fittler A., Lankó E., Brachmann B., Botz L. (2013), Behaviour analysis of patients who purchase medicines on the internet: Can hospital pharmacists facilitate online medication safety?, *European Journal of Hospital Pharmacy: Science and Practice*, 20, pp. 8-12.

Innovative trends for the alcohol enterprises of Ukraine

Liudmyla Shevchenko

National University of Food Technologies, Kiev, Ukraine

Abstract

Keywords:

Innovation
Activity
Profit
Technology
Alcohol

Article history:

Received 21.09.2015
Received in revised
form 16.12.2015
Accepted 24.12.2015

Corresponding author:

Liudmyla Shevchenko
E-mail:
milana1801@i.ua

Introduction. The theme of our exploration is devoted to the problem of the developing of Ukrainian enterprises of alcohol industry, which are in a very negative condition nowadays. One of the methods of improving the condition of the alcohol enterprises is the creation the mechanism to increase profitability by implementing innovations.

Materials and methods. To make a research we used methods of analysis. Using the method of statistics analysis, we can see the proportions of innovations in European industry and using method of comparison for further research. To analyze the concept of innovation and the need for innovation in the business, improving the profitability and competitive ability of the company theoretical method was used.

Results. The alcohol industry of Ukraine needs resuscitation and entering new markets for selling of alcohol. For Ukraine, it is necessary to invest in innovative retooling factories and convert part of the plant to produce other products.

For the purpose of successful and competitive development of enterprises of alcohol industry is suggested the mechanism to increase profitability by implementing of innovation activity. The mechanism consists of such constituents such as strategic planning, which included the pre-planning and strategic planning processes. The next constituent is to determine the methods of increasing the profit for enterprises of alcohol industry. To reach this the implementation of innovation in technological process to reduce the production costs of alcohol is necessary. This step makes it possible to reduce the price of alcohol for sale. In addition the enterprises of alcohol industry would have the possibility to enter new markets.

The next step is to create the fund of innovation. The next constituent is to reduce the risk for enterprises of alcohol industry to innovate. For example to use grants covering a percentage of business costs, which can be awarded for defined activities on either a first-come-first-serve or competitive bidding basis. The last step is to achieve the support of the government in providing innovation activity for enterprises of alcohol industry.

Conclusion. A complex approach to the study of innovation activity allowed not only to analyze precisely the materials but to reach specific conclusions, based on the analysis that we need to implement technical innovations, organizational innovations, economic innovations, it is necessary to improve the function of forecasting and planning, social innovations, legal innovations.

Introduction

The innovative development of companies is a part of the innovation economic development and is an important aspect reproduction of industrial relations which consists the updating of the composition and construction of capital assets and improving of their use as in its formative stages, and scientific technical preparation of production.

We can't underestimate the importance of innovation for the development of a modern economy of Ukraine. It is through innovation the economic growth can be achieved in the nearest future. The innovative development as a fundamental factor in economic recovery reflected in fundamental studies of foreign scholars such as R.Akoffa, P.Drukera, F.Portera, B.Santo, B.Tvissa.

There are many works in which the main subject is the problem of innovative development of companies, in which such questions are discussed: the content, factors, trends, strategies and methods of such development, its influence on the development of the state and the regions, some industries and enterprises. The leading The most famous Ukrainian researchers mentioned directions of innovative development companies: VP Aleksandrov, IV Alekseev, AI Amosha., SS Pharmacist, VM Heets, VM Goncharov, MI vale, VI Landik, MN Lepa, O. Savchuk, MG Chumatchenko, IB Shvets.

Perhaps the best known is the concept of creative destruction. Joseph Schumpeter was a renowned economist who first coined the term. He argued that innovative thinkers develop new products and technologies that over time make obsolete a product or process that had once dominated its market. The innovation often starts at the low end of the market (for example, with lower priced goods or components of higher end products) and slowly works up to the higher end, taking market share from the big players as processes and products improve. Schumpeter's relationships with the ideas of other economists were quite complex in his most important contributions to economic analysis – the theory of business cycles and development. Following neither Walras nor Keynes, Schumpeter starts in *The Theory of Economic Development* with a treatise of circular flow which, excluding any innovations and innovative activities, leads to a stationary state. The stationary state is, according to Schumpeter, described by Walrasian equilibrium [1].

Schumpeter was the most influential thinker to argue that long cycles are caused by innovation, and are an incident of it. His treatise on business cycles developed were based on Kondratiev's ideas which attributed the causes very differently. Schumpeter's treatise brought Kondratiev's ideas to the attention of English-speaking economists.

We often think of innovation today in terms of technology. While it's true that technological innovations in the recent past have been groundbreaking, innovation can come in many forms. It can be a creative new teaching method to enhance student engagement. It can be a unique incentive program to reward high performing employees. Or it can be a process, such as lean methodology, a model which streamlines workflows and eliminates waste to keep costs low while maintaining quality. Innovation can be incremental, such a slight variation on an existing product formulation (like adding a new color or fragrance), or a groundbreaking product that revolutionizes an industry. Innovation can respond to a clearly defined problem, or create a complete paradigm shift when the problem itself is undefined or the path to a solution is unclear.

The advantages of innovation are not limited to new product development. The models of innovation are just about as numerous as the objectives they are intended to serve. Innovation can improve almost every aspect of a product or service life cycle, from business model innovation to pricing strategies, marketing and service delivery. Think of how discount airlines, such as Southwest, transformed the airline industry with innovative

transformed e-commerce with its innovative distribution channels, making a huge array of products available nationwide virtually overnight [12].

Innovation is not always a new product. Sometimes innovation makes an existing product or service better. Small entrepreneurial businesses often develop new products that are components of products that larger, more established firms manufacture and sell under an established brand name. Cutting edge component parts or pioneering research and development were provided by smaller firms with innovative ideas. Some small firms have built their entire business models around developing and producing products that help larger, well-known companies be more efficient or effective, and ultimately more competitive.

During difficult economic periods, innovation is touted as a source of value creation in part because firms that implement innovations countercyclical are often more prepared to rebound when times get better.

However, the problems of innovation potential at the micro level which is represented companies are not resolved yet. The innovative development means for companies to ensure the production of certain goods and services to specific market segments. Implementation of such tasks require companies providing all kinds of resources and achieve the best way to use them.

Materials and methods

To make a research we used methods of analysis and synthesis, inductive method, axiomatic method, deductive method, theoretical analysis and graphic methods.

Using the method of statistics analysis, we found the proportions of innovations in European industry.

Using the methodology of complex analysis of economic activities, we investigated the enterprises of alcohol industry.

Using methods of grouping and organizing study status and the laws of development of the objects (distilleries), and determine the influence of factors on the performance of businesses and the counting of unused reserves and promising to improve production efficiency.

To analyze the concept of innovation and the need for innovation in the business, improving the profitability and competitive ability the company theoretical method is using.

Results and discussions

The innovative development of Ukraine can provide the basis for sustainable economic growth, which contributes to approximation of the living standards of Ukraine to the level of developed countries. So its role and place of the innovative development determined in the provision of strategic objectives and interests.

The development of innovation potential in macro-and microeconomic levels are becoming more relevant for Ukraine that is mainly due to the understanding of the positive role of innovation to overcome with difficult economic situation.

It is very important to develop the appropriate mechanism to increase the profitability of the enterprises of alcohol industry by implementation of innovative activity.

According to our opinion the mechanism for the enterprises of alcohol industry should include:

1. The creation a team of strategic managers;

2. The creation of strategy of development (strategic planning);
3. The methods of increasing of profit;
4. The creation of innovation fund;
5. The methods to reduce the risk for businesses to innovate;
6. The support of the government.

At first we need to discover the innovative potential of the enterprises of alcohol industry.

The innovative potential is a comprehensive description of the capacity of enterprises to innovation activities. This concept is conceptual reflection of the phenomenon of innovation. Recently, it was included among the terms of economics as an economic category, but in the modern economic literature, including Ukrainian, there is no unambiguous definition of it. In research works the term is used at solving other scientific and cognitive tasks. In many studies the authors focus their efforts on the study of individual innovative capacity, that's why there are a lot of specific definitions in the literature.

Analysis of the economic aspects of the concept of "innovation potential" reveals wide range of approaches to its study. Consider some of them:

1. "Innovation potential - is one of three components of innovation space, which includes a "personal and business leaders skills, professional and economic training, professional achievements (author's certificate inventions, etc.), logistical and financial support";
2. "Innovative potential - a set of different resources, including physical, financial, intellectual, informational and other resources needed to implement innovation";
3. "Innovation potential has unused hidden capabilities accumulated resources that could be used to achieve purposes of economic entities";
4. "Innovative potential of the region is a special category, which includes not only innovative resources and mechanisms for their use in organizational and economic system, but also the activity of innovation processes in regional economy"[1].

Innovation activities are all scientific, technological, organizational, financial and commercial steps which actually lead to the implementation of innovations. Some innovation activities are themselves innovative, others are not new activities but are necessary for the implementation of innovations. Innovation activities also include process of researching and development that is not directly related to the development of a specific innovation.

A common feature of an innovation is that it must have been implemented. A new or improved product is implemented when it is introduced on the market. New processes, marketing methods or organizational methods are implemented when they are brought into actual use in the firm's operations.

Innovation activities vary greatly in their nature from firm to firm. Some firms engage in well-defined innovation projects, such as the development and introduction of a new product, whereas others primarily make continuous improvements to their products, processes and operations. Both types of firms can be innovative: an innovation can consist of the implementation of a single significant change, or of a series of smaller incremental changes that together constitute a significant change.

To make your business profitable you need to create a strategic development plan. Strategic management goes beyond the development of a strategic plan, which included the pre-planning and strategic planning processes. Strategic management is the deployment and implementation of the strategic plan and measurement and evaluation of the results. Deployment involves completing the plan and communicating it to all employees. Implementation involves resourcing the plan, putting it into action, and managing those

actions. Measurement and evaluation consists not only of tracking implementation actions, but, more importantly, assessing how the organization is changing as a result of those actions and using that information to update the plan [11].

To be the most successful, leaders need to be facilitators, coaches, consultants, and consensus-builders. Transformational leadership is described by Bernard Bass as, superior leadership performance that occurs when leaders broaden and elevate the interests of their employees, when they generate awareness and acceptance of the purposes and mission of the group, and when they stir their employees to look beyond their own self interest for the good of the group. Acquiring transformational leadership traits requires hard work and dedication, willingness to take some risks, and internalizing the organizations vision and guiding principles.

Indicators for assessing the outputs and outcomes of business innovation measures should permit an analysis of the quantitative impacts on business innovation activities and results and the verifiable changes in co-operation patterns within other actors in the innovation system. They should also facilitate a qualitative assessment of the extent to which the intervention has improved in-house capacities of firms to continue to invest effectively in innovation and to extend or strengthen knowledge acquisition and exchange [15].

Illustrative evaluation questions and indicators that may be used to focus an evaluation are set out below (Table 1).

Strategic planning is an organizational management activity that is used to set priorities, focus energy and resources, strengthen operations, ensure that employees and other stakeholders are working toward common goals, establish agreement around intended outcomes/results, and assess and adjust the organization's direction in response to a changing environment. It is a disciplined effort that produces fundamental decisions and actions that shape and guide what an organization is, who it serves, what it does, and why it does it, with a focus on the future. Effective strategic planning articulates not only where an organization is going and the actions needed to make progress, but also how it will know if it is successful.

Alcohol industry is one of the most profitable industries in Ukraine. Alcohol is used in distillery and liquor industry, in perfumes and cosmetics and confectionery industry, in vitamin production, medicine and engineering. Baking and fodder yeast, liquid carbon dioxide, feed vitamins are produced in alcohol plants.

Table 1

Indicative evaluation questions & illustrative indicators for funding for business innovation

Indicative evaluation questions	Examples of possible indicators
<ul style="list-style-type: none"> - To what extent is the measure focused on firms or sectors of the regional economy facing specific difficulties to innovate or with a specific potential? - Is the measure reaching firms with a latent potential to innovate? 	<ul style="list-style-type: none"> - % of firms assisted which previously reported negligible R&D or innovation expenditure - Renewal rate (% of previously non-assisted enterprises supported)
<ul style="list-style-type: none"> - Is the public funding being disbursed using the least possible (human and financial) resources by the implementing agency? - Are the application, selection and funding procedures managed so as to minimise the cost to beneficiaries? 	<ul style="list-style-type: none"> - Managerial efficiency (e.g. management cost per euro disbursed compared to benchmark programme). - Stakeholders assessment of programme management (qualitative) Satisfaction of beneficiaries with programme procedures (survey/interview returns)
<ul style="list-style-type: none"> - Has the funding provided generated additional innovation activity in the beneficiary firms? - Have the projects outcomes improved competitiveness of the beneficiary firms? 	<ul style="list-style-type: none"> - Trend in R&D intensity (R&D expenditure as a share of turnover) compared to baseline (preintervention) - Trend in performance indicators such as sales from new products/services; growth in productivity, etc.
<ul style="list-style-type: none"> - Has the funding induced learning and/or built capacity in beneficiary firms enabling them to maintain their innovation intensity? - Have new co-operation linkages been developed between beneficiary firms (and/or with other innovation system actors: financial intermediaries, etc.)? 	<ul style="list-style-type: none"> - Post-project change in innovation expenditure, retention or additional hiring of qualified personnel to manage innovation; - Identification of new co-operation patterns (survey or monitoring data).

Alcohol industry in Ukraine requires the implementation of significant reforms in alcohol production. The main enterprise of alcohol industry in Ukraine is the State Enterprise of alcohol and liquor industry "Ukrspirt" (SE "Ukrspirt"). It was formed in 2010. It was formed by attaching of the 41 plants. SE "Ukrspirt" was created to control the volume of production and sale of alcohol in Ukraine.

The State Enterprise of alcohol and liquor industry "Ukrspirt" (SE "Ukrspirt") is the only authorized producer (a monopolist) of ethyl alcohol in Ukraine, which is mainly used for the production of alcoholic beverages.

The main products are:

1. Ethyl alcohol that is made by grain;
2. Ethyl alcohol technical;
3. Vodka;
4. Bioethanol;

5. Technical products and household chemicals;
6. Fraction of ethanol;
7. Fusel oil;
8. Concentrate of Esther – fusel;
9. Carbon dioxide;
10. Concentrates of kvass wort;
11. Brewer’s malt.

Alcohol industry in Ukraine is at 25 percent of its capacity for the production of ethyl alcohol, but fully satisfies the internal needs of the state in ethyl alcohol.

Permanent decline in production and sale of alcohol is shown in Table 2.

Unfortunately, during the last eight years management of a company did not spend money not only for renewal of fixed assets, but also of maintenance of equipment at the vast majority alcohol factories.

But State Enterprise ”Ukrspirt” has some problems and innovation activities can help to resolve this problems. The main problem of alcohol factories in Ukraine is old equipment that needs to be upgraded.

Also we need to notice a service innovation. Service innovation is defined as the introduction of novel ideas that focus on services that provide new ways of delivering a benefit, new service concepts, or new service business models through continuous operational improvement, technology, investment in employee performance, or management of the customer experience.

Table 2
Production and realization of SE ”Ukrspirt” (2011-2013)

Index	2011, thousand decaliters		2012, thousand decaliters		2013, thousand decaliters	
	production	realization	production	realization	production	realization
Alcohol:	15 620,39	15 233,09	13 516,79	14 227,94	14 616,42	12 311,17
ethyl alcohol	14 510,50	14 115,41	12 253,21	13 003,82	12 856,79	10 628,10
technical alcohol	1 109,89	1 117,68	1 263,58	1 224,12	1 759,63	1 683,07
Component of motor fuel alternative	1 208,86	1 215,83	2 107,23	2 153,06	5 061,89	4 938,50
Production	945,20	867,00	622,93	713,34	402,89	435,88
Bioethanol	793,72	767,40	1 240,65	1 321,43	4 393,26	4 389,09
Total	18 568,17	18 083,32	17 487,60	18 415,77	24 474,46	22 074,64

The nature of services may explain the limited research that has explored innovation and its implementation. Labor intensity, high variability of delivery, coproduction with the consumer, intangibility, and the perish ability or time sensitivity of services makes innovation in services substantially different in type and in adoption processes from the innovations in traditional manufacturing settings.

Given that focus on customers, and the critical role of the social system in the implementation of change, it is likely that the success of implementing service innovations relies on appropriate processes and administrative structures. Service innovation rests on

both creating something new, and on coproducing it. One clear feature of service innovation is that it is characterized as having a greater organizational dimension than innovations in manufacturing contexts. Indeed some researchers have argued that a firm's long-term success may rely more on an overall firm-level innovation orientation that produces the capabilities that spawn innovations and less on specific innovations.

A strong climate for the implementation of service innovations that takes into account how the innovation fits the company's value proposition and stresses employee motivation has also been given some conceptual and empirical attention.

Once an innovation has been selected, postadoption processes constitute the internal diffusion strategies directed toward members of a social system. Postadoption implementation approaches involve the ways in which information about the new idea are shared with those employees who must execute on the innovation. Even though this execution stage is most often identified with innovation failure, it receives the least attention from innovation researchers.

In the implementation process, the nature of the information exchange relationship determines the conditions under which an employee receives knowledge or has experience using the new idea. Several different information-exchange strategies can be used, including those focused on individuals, typically, individual counseling by managers or change agents, and those at the group level, such as staff meetings, cross-functional teams, and focus groups.

Most EU countries have a number of measures to support science and industry collaboration that fall into two broad types. The first type supports one-off, smaller scale projects, whereby researchers from a firm and research institute work together, with a clear division of labour, to achieve a scientific, technological or innovation objective. Such interventions (e.g. innovation vouchers) often focus on resolving a specific technological problem, or developing a prototype for a new product.

At the other end of the spectrum, a second type of measure supports research institutes and firms to engage in longer-term strategic collaboration. These interactions can range from looser networking on a key enabling technology for the regional economy to the establishing and joint governance of a formal legal entity with firms and research institutes as shareholders.

Direct financial support to enterprises to undertake product development, enhancing product design, prototyping, process innovation, technology acquisition, organisational change, improvements to product marketing, etc. is possibly the most prevalent innovation measure in industrialised countries. In the EU, State Aid rules limit the scope of subsidies to business R&D projects or equity financing, in early-stage financing of innovative firms, provided from Government funds. Whilst the forms of support vary, all aim to reduce the risk for businesses to innovate:

- grants covering a percentage of business R&D costs, which can be awarded for defined activities on either a first-come-first-serve or competitive bidding basis;
- soft loans provided either directly by a government agency or through commercial banks or other financial intermediaries. In some cases, such loans may be reimbursable only under specific conditions (e.g. in the event that a product development project is successful and the company generates new sales);
- government loan guarantees intended to facilitate the granting of business loans by commercial banks or other financial intermediaries reducing the need for businesses to provide collateral when applying for a loan.

- government support to seed capital, business angel networks and early stage venture capital funds, which may take one of several forms: creation of a fund-of-funds, co-investment, etc.

The classic argument for Government support to business innovation activity is the existence of a ‘market failure’: a company that invests in innovation is unable to capture the full returns as it cannot stop other firms from copying or further developing the technology. This leads to a socially non-optimal level of investment in R&D as well as non-technological forms of innovation. Public funding of innovation projects aims to assist firms to do materially more development work than would be the case otherwise, producing more innovation.

Evaluations of business innovation measures seek to elucidate the impact of one or more funding measures on the innovation activity of the target enterprises. Often funding measures are launched as a ‘suite’ of support with, at least on paper, an inter-linkage between say a small ‘innovation voucher’.

Conclusion

We have to implement novelties and innovations: technical innovations - new products, technology, construction, equipment, organizational innovations - new methods and forms of all types of activities of SE “Ukrspirt” and their institutional department, economic innovations – improving methods of economic management, it is necessary to improve the function of forecasting and planning on SE “Ukrspirt”, it is necessary to improve the methods of financing, pricing methods, methods of motivation and remuneration, social innovations - different forms of activation of human capital, including new forms of professional training, encouraging his creativity, promotion of his work, creating comfortable living and working conditions; legal innovations - we need new and transformed various laws and legal documents (laws) that define and regulate all activities of enterprises and organizations or certain groups or individuals.

References

1. Arora Ashish, Fosfuri Andrea, Gambardella Alfonso (2012), *Markets for Technology: The Economics of Innovation and Corporate Strategy*, MIT Press, Cambridge.
2. Barnett J., Vasileiou K., Fayika D., Brooks L., Young Y. (2013), «Understanding Innovators» Experiences of Barriers and Facilitators in Implementation and Diffusion of Healthcare Service Innovations: a Qualitative Study, *Health Services Research*, 11 (1), p. 342.
3. Brooks H., Pilgrim D., Rogers A. (2014), Innovation in Mental Health Services: What Are the Key Components of Success?, *Implementation Science*, 6 (1), p. 120.
4. Chen C.J., Huang J.W. (2012), Strategic human resource practices and innovation performance – the mediating role of knowledge management capacity. *Journal of Business Research*, 62(1), pp. 104–114.
5. Costa K. (2011), *Innovation for the Public Good: Financing Tools for Social Innovation. Three Financing Principles to Guide Social Innovation*, Center for American Progress.

6. Djellal F., Gallouj F. (2014), Social Innovation and Service Innovation, *Power point presentation at the Challenge Social Innovation Conference, Vienna, 19-21 September 2014*.
7. Herrera L., Muñoz-Doyague M.F., Nieto M. (2010), Mobility of public researchers, scientific knowledge transfer and the firm's innovation process, *Journal of Business Research*, 63, pp. 510–518.
8. Hurmelinna-Laukkanen P., Ritala P. (2014), Protection for profit from collaborative service innovation, *Journal of Service Management*, 21(1), pp. 6-24.
9. Murray A. (2011). Tapping university innovation, talent, *Business Economic Review*, 55(3), pp. 14–19.
10. Newman J.L. (2012), *Building a CREATIVE high-performance R&D culture*. *Research Technology Management*, New York.
11. Powell Walter W., Kenneth W. Koput, Laurel Smith-Doerr (2013), Interorganizational collaboration and the locus of innovation: Networks of learning in biotechnology, *Administrative Science Quarterly*, 41(1), pp. 116-145.
12. Salge T.O., Vera A. (2012), Benefiting from Public Sector Innovation: The Moderating Role of Customer and Learning Orientation, *Public Administration Review*, 72(4), pp. 550-560.
13. Schilling A., Werr A. (2014), *Managing and organizing for innovation in service firms. A literature review with annotated bibliography*, Vinnova Report.
14. Wamae W. (2010), Enhancing the role of knowledge and innovation for development, *International Journal of Technology, Management and Sustainable Development*, 8(3), pp. 199-220.
15. Available at: http://ec.europa.eu/regional_policy/sources/docgener/evaluation

Анотація

Безпека харчових продуктів

Дослідження токсикологічного і фармакологічного впливу нових купажів на організм біологічних об'єктів

Наталія Пенкіна¹, Лариса Татар¹, Ганна Зайченко², Дмитро Литкін²

1 – Харківський державний університет харчування та торгівлі, Харків, Україна

2 – Національний фармацевтичний університет, Харків, Україна

Вступ. Мета дослідження – токсикологічне вивчення купажу з рослинної сировини, який використовується для виготовлення слабоалкогольних напоїв.

Матеріали і методи. Напій, виготовлений методом натурального бродиння, містить 4,0 % алкоголю та суміш екстрактивних речовин різних рослин із високою антиоксидантною активністю. Вивчали підгостру токсичність купажу та його вплив на прооксидантно-антиоксидантний стан печінки білих мишей порівняно з розчином спирту 4,0 % і пивом 4,0 %.

Результати і обговорення. Після внутрішньошлункового введення купажу в максимальній одноразовій для мишей дозі (36,1 г/кг упродовж 14 днів) ознак інтоксикації у тварин не спостерігалось. Середня маса тварин (24,33 г) не виходила за межі фізіологічної норми та, ймовірно, не відрізнялася ($p > 0,05$) від показників середньої маси тварин групи інтактного контролю (24,33 г).

Масові коефіцієнти печінки (0,1г/10,0г) у тварин інтактного контролю (38,567) і тих, яким вводили купаж (39,467), значно відрізнялися від печінки тварин, яким вводили пиво (42,867) та розчин етилового спирту (45,633), – це початок розвитку компенсаторних проявів, зокрема гіпертрофії органу. Купаж зменшує загальнотоксичний вплив алкоголю на організм тварин і не викликає збільшення коефіцієнта маси печінки.

Біохімічні дослідження гомогенату тканин печінки тварин, яким вводили купаж, показали, що вміст у печінці дієнових кон'югатів (3,633 мкмоль/г), ТБК-реактивів (2,500 мкмоль/г), відновленого глутатіону (2,420 мкмоль/г) і каталази (0,163 мкмоль/хв·г) статистично не відрізнявся від показників у тварин інтактного контролю та перебував у межах фізіологічної норми. У групі тварин, яким вводили пиво, знижувався вміст відновленого глутатіону (2,267 мкмоль/г) та зменшувалася активність каталази (0,153 мкмоль/хв·г). У групі тварин, яким вводили розчин спирту, ймовірна зміна ($p < 0,05$): зростав вміст ТБК-реактивів (3,033 мкмоль/г), знижувався вміст відновленого глутатіону (2,333 мкмоль/г) та пригнічувалася активність каталази (0,157 мкмоль/хв·г).

Висновки. Напої на основі досліджуваного купажу завдяки наявності алкопротекторної дії на печінку можуть бути альтернативою сучасним пивним і слабоалкогольним напоям, які виробляються з використанням спирту етилового.

Ключові слова: *напій, антиоксидант, токсичність, спирт, купаж.*

Харчові технології

Вплив типу злаків і методу сушіння на функціональні властивості та пастоподібність порошку огі

Естер Ладуні¹, Адевуні Оєінка², Самсон Оєінка³, Чарльз Ауор¹
1 – Ібаданський університет, Нігерія

2 - Ілорінський університет, м. Ілорін, Нігерія

3 - Кварський державний університет, м. Малете, Нігерія

Вступ. Огі, також відомий як рідка каша, є ферментованим харчовим продуктом, що готується зі злаків. Мета дослідження полягає у вивченні впливу методів сушіння і типу злаків на функціональні властивості порошку огі.

Матеріали і методи. Кукурудза, просо та сорго (червоний сорт) були одержані з місцевого ринку в Ібадані (Нігерія). Огі готувався традиційними методами. Одержана суспензія сушилася в камері і методом сушіння у спіненому шарі. Пастоподібність та інші функціональні властивості сухого огі були оцінені типовими методами.

Результати і обговорення. Метод сушіння не впливає на рН і здатність до гелеутворення огі, одержаного з кукурудзи, проса та сорго. Однак і метод сушіння, і тип злаку впливають на пастоподібність та інші функціональні властивості сухого порошку огі. Зразки огі, висушеного у спіненому шарі, демонструють значно ($p < 0,05$) нижчий пік в'язкості, ніж зразки, висушені в камері. При зростанні концентрації спінювального агента від 5 до 15 % пік в'язкості висушеного огі іде на спад. Однак огі, висушений у камері, готується швидше (78-79 °C), ніж зразки огі, висушені у спіненому шарі (80- 95 °C), що зумовлено їх температурами пастоутворення. Зразки, одержані методом сушіння у спіненому шарі, в цілому мають вищі значення водопоглинання, ніж зразки, висушені у камері.

Висновки. Порошок огі, висушений у спіненому шарі, продемонстрував кращу здатність до диспергування та поглинання води, піноутворення та в'язкість порівняно зі зразками, висушеними в камері. Вибір конкретного методу сушки для огі залежить лише від бажаного виду застосування.

Ключові слова: огі, кукурудза, просо, сорго, піна, сушіння, функціональність.

Кінетика гідролізу-екстрагування пектинових речовин картопляної сировини

Олена Грабовська¹, Ганна Пастух¹, Оксана Деменюк¹, Володимир Мірошник²,
Тетяна Галатенко¹, Аліна Бабій¹, Аліна Добридюк¹

1 – Національний університет харчових технологій, Київ, Україна

2 – Національний університет біоресурсів і природокористування, Київ, Україна

Вступ. Гідроліз-екстрагування пектинових речовин з рослинної сировини є одним з найскладніших і найважливіших процесів технології отримання пектину, тому дослідження впливу технологічних параметрів на кінетику цього процесу є актуальним.

Матеріали і методи. Предметом дослідження був процес гідролізу-екстрагування пектину з картопляної мезги з використанням хлоридної кислоти. Вихід пектину визначали у відсотках до маси сухих речовин. Кінетичні константи розраховували за рівнянням реакції першого порядку. Обробку експериментальних

даних, вибір рівнянь, розрахунків та уточнення коефіцієнтів цих рівнянь здійснювали з використанням методу найменших квадратів.

Результати. На основі проведених експериментальних досліджень побудовано кінетичні криві процесу гідролізу-екстрагування пектинових речовин з картопляної мезги з урахуванням температури та рН середовища. Найбільший вплив на швидкість реакції гідролізу протопектину має рН середовища. За недостатнього вмісту кислоти як каталізатора процесу навіть за високих температур швидкість реакції не значна. Гідроліз протопектину супроводжується небажаними реакціями, пов'язаними з деструкцією пектину, що ускладнює визначення константи швидкості реакції. Шляхом планування експерименту і статистичного оброблення експериментальних даних визначено оптимальні параметри процесу гідролізу-екстрагування картопляного пектину: температура - 75°C, рН гідролізованої маси - 1,6; тривалість гідролізу - 72 хвилини.

Висновки. Застосування результатів досліджень під час виробництва пектину забезпечить максимальний вихід пектину без порушення його структури.

Ключові слова: *пектин, кінетика, гідроліз, екстрагування, картопля, мезга.*

Якість висушеного солодкого перцю після зберігання

Міхаель Одеволе¹, Зайнаб Айодімеджі¹, Кехінде Алабі²

1 - Ілорінський університет, м. Ілорін, Нігерія

2 - Кварський державний університет, м. Малете, Нігерія

Вступ. Свіжий солодкий перець швидко псується, однак після попередньої обробки і сушіння можна подовжити термін його придатності. Під час зберігання продукти можуть втрачати поживні речовини і піддаватися впливу бактерій.

Матеріали і методи. Досліджувався попередньо оброблений солодкий перець. Показники кольору визначались за Colour reference standard ISO 9002 з використанням АОС тинтометра, Pt-Co (30 кольорів), мікробне навантаження визначено методом Коха з використанням термостата DHG 1923A. Вміст вітамінів А і С визначався згідно з офіційними методиками Асоціації аналітичної хімії (Вашингтон).

Результати і обговорення. З таблиці дисперсійного аналізу видно, що лише вплив кольору як вхідного параметра та його взаємодій був незначимим за $p \leq 5\%$, а всі інші параметри та їх взаємодії істотно впливають на вміст вітамінів А і С. Падіння у відсотках вмісту вітамінів А і С до і після зберігання за різних умов перебігу процесу склали 53,1% і 53,4% відповідно.

Мікробне навантаження становило 6×10^6 КУО/мл, що знаходиться в межах допустимого діапазону (10^7 КУО/мл і 10^8 КУО/мл) для готових до вживання овочів. Було відмічено також краще збереження кольору (темно-жовтий) у попередньо оброблених зразках і висушених необроблених зразках з глибоким коричневим кольором. Т-тест показав істотну відмінність між вмістом вітамінів А і С до і після зберігання. Всі вищезазначені зауваження щодо результатів пояснюються різними факторами (умови довкілля, тип носія даних, характер свіжих зразків у процесі росту та під час збору врожаю, вантажно-розвантажувальні роботи до, під час і після обробки й зберігання, умови обробки проб перед зберіганням, тривалість знаходження зразків у носії тощо). Рівняння регресії були розроблені для вмісту вітамінів А і С, бактеріологічного навантаження і кольору. Лише рівняння вмісту вітаміну А не мають достатньої прогнозувальної сили.

Висновки. В попередньо оброблених сушених зразках солодкого перцю мікробіологічні показники і показники поживних речовин були в нормі після 20 місяців зберігання, до того ж сировина мала краший колір (темно-жовтий). Розроблені рівняння регресії можуть бути використані для прогнозування вмісту вітаміну С, мікробного навантаження і кольору.

Ключові слова: солодкий перець, зберігання, мікробіологія, вітамін, якість.

Біотехнологія, мікробіологія

Визначення і характеристика бактерійних і грибових ізолятів у зразках сирого молока від різних порід корів

Мусліу Олушоло Сунмону, Майкл Майокун Одеволе,
Аліу Оламідє Оєдун, Хафсат Фунмілайо Банколен
Лорінський університет, м. Лорин, Нігерія

Вступ. У дослідженні проаналізовано методи характеристики та визначення бактерійних і грибових ізолятів у зразках сирого молока від різних порід корів.

Матеріали і методи. Для дослідження були зібрані зразки молока від корів білий фулані і джерсійська, а також змішаної породи (білий фулані і джерсійська). Потім зразки були згруповані по чотири і пастеризовані за температури 71 °C протягом 15 секунд, 66 °C протягом 15 хвилин і 61 °C протягом 30 хвилин з використанням пастеризаторів з алюмінію, нержавіючої й оцинкованої сталі.

Результати і обговорення. Зразки сирого молока досліджувалися на наявність бактерійних і грибових ізолятів: *Staphylococcus aureus*, *Bacillus subtilis*, *Euterobacter aerogenes*, *Escheria coli*, *Streptococcus lactis*, *Proteus vulgaris*, *Pseudomonas aeruginosa*, *Serratia marcescens* і *Lactobacillus* - для бактерійних ізолятів і *Aspergillus flavus*, *Aspergillus niger*, *Penicillium citrinum*, *Sacchanomyces Cerevisae*, *Paecilomyces Varioti*, *Penicillium Chrysogenum* — для грибових ізолятів. *Staphylococcus aureus* був виявлений у 78,79 % усіх зразків до і після пастеризації. Найчастіше в зразках сирого молока корів породи білий фулані, джерсійська і змішаної породи, а також в місцевому напої із зброженого молока (ноно) зустрічаються бактерії *S. aureus*. Частота виявлення інших бактерій у зразках молока така: *B. subtilis* (6,06 %), *E. aerogenes* (42,42 %), *E. coli* (3,03 %), *S. lactis* (48,48 %), *P. vulgaris* (18,18 %), *P. aeruginosa* (30,30 %), *S. marcescens* (33,33 %), *L. fermentum* (30,30 %). Відсотковий розподіл грибових ізолятів такий: *A. flavus* (54 %), *A. niger* (18,18 %), *P. citrinum* (21,21 %), *S. cerevisae* (57,58 %), *P. varioti* (15,15 %), *P. chrysogenum* (6,06 %). Найменший вміст бактерій був отриманий після пастеризації зразків за 71°C протягом 15 секунд у пастеризаторі з нержавіючої сталі. Таким чином, найкращий результат досягається під час швидкої пастеризації за високих температур. Для зниження кількості грибових ізолятів слід використовувати пастеризатор з нержавіючої сталі і проводити обробку при 61°C протягом 30 хвилин.

Висновки. В процесі дослідження в зразках сирого молока, отриманих від корів різних порід, було виділено дев'ять бактерійних і шість грибових ізолятів.

Ключові слова: молоко, бактерія, грибок, пастеризація.

Ефективність дії дезінфектантів щодо мікроорганізмів – активних збудників кагатної гнилі під час зберігання цукрових буряків

Наталія Гусятинська¹, Світлана Тетеріна¹, Тетяна Нечипор¹, Ірина Касян²

¹ – Національний університет харчових технологій, Київ, Україна

² – Смілянський технікум харчових технологій НУХТ, Сміла, Україна

Вступ. Основною причиною втрат бурякомаси та сахарози, а також різкого зниження якості сировини та напівпродуктів є загнивання коренеплодів у кагатах внаслідок виникнення мікробіологічних процесів.

Матеріали і методи. Як об'єкти дослідження обрано чисті культури слизоутворювальних бактерій роду *Leuconostoc* і міцеліальних грибів, які є активними збудниками кагатної гнилі цукрових буряків; коренеплоди селекції "Огук"; дезінфікуючі засоби нового покоління.

Результати і обговорення. Визначення активності збудників кагатної гнилі проводили за різних термінів і температури зберігання коренеплодів, попередньо уражених певним видом збудника кагатної гнилі.

Так, гриб *Botrytis cinerea Pers* є дуже активним збудником кагатної гнилі. Підвищення температури зберігання до 15...20 °С сприяє розвитку *Mucorales* та найбільш розповсюджених видів *Mucor mucedo* та *Rhizopus nigricans*, які за короткий термін здатні перетворити буряк у непридатний до перероблення стан.

У пробах цукрових буряків, уражених *Geotrichum candidum* і *Torula beticola*, під час зберігання за температури 0...5 °С протягом 45 діб спостерігалась наявність зовнішнього міцелію, але розвиток кагатної гнилі практично не відбувся.

Засоби «Санітарін», «Жавель-Клейд», «Біодез» і «Гембар» виявили високу ефективність щодо міцеліальних грибів, що є представниками різних родів. Засіб «Нобак-фермент» порівняно із засобом «Нобак» виявляв високий антимікробний ефект до більш широкого спектра мікроорганізмів. Засіб «Бетастаб» виявив високу ефективність щодо слизоутворювальних бактерій, зокрема роду *Leuconostoc*, хоча за даних значень витрат цей засіб не є ефективним щодо мікроміцетів. Дезінфікуючий засіб «Каморан» є активним щодо різних груп мікроорганізмів, в тому числі мікроміцетів і слизоутворювальних бактерій.

Висновок. Більшість досліджуваних засобів мають стабільну фунгіцидну та фунгістатичну дію щодо широкого спектра мікроміцетів та ефективні щодо пригнічення розвитку слизоутворювальних бактерій.

Ключові слова: дезінфектант, мікроміцет, слизоутворення, бактерія, цукор, буряк.

Процеси і обладнання харчових виробництв

Двоетапна переробка молочної сироватки нанофільтрацією і зворотним осмосом

Іванна Киричук¹, Валерій Мирончук¹, Юрій Змієвський¹, Сергій Голячук²

¹ – Національний університет харчових технологій, Київ, Україна

² – Луцький національний технічний університет, Луцьк, Україна

Вступ. Перероблення молочної сироватки, яка є побічним продуктом сироробного виробництва, представляє великий інтерес для молочної промисловості

з огляду на високий вміст у ній цінних і поживних речовин. Проте актуальним залишається питання розроблення комплексного перероблення сироватки, в тому числі мембранними методами, та шляхів використання продуктів її розділення.

Матеріали і методи. Для дослідів використовували молочну сироватку та пермеат, отриманий після її концентрування нанофільтрацією. Експерименти проводилися на установці непроточного типу з використанням нанофільтраційної ОПМН-П і зворотноосмотичної НаноРо мембран.

Результати. Враховуючи високий вміст лактози у сироватці та результати, отримані при розділенні розчинів лактози на мембрані ОПМН-П, обґрунтовано доцільність концентрування молочної сироватки нанофільтрацією до вмісту сухих речовин у ній в межах 20-22 %. Під час концентрування сироватки спостерігали дві стадії зниження питомої продуктивності: швидке зниження на початку процесу і подальше поступове зростання. Перша стадія зумовлена забрудненням мембрани, а друга - концентраційною поляризацією, утворенням шару осаду й зростанням його товщини.

Відповідно до аналізу отриманих залежностей питомої продуктивності та селективності зворотноосмотичної мембрани НаноРО від тиску встановлено, що раціональне значення тиску для проведення процесу концентрування пермеату після нанофільтрації молочної сироватки складає 3,0 МПа. При такому тиску питома продуктивність знизилася вдвічі зі зростанням концентрації розчину від 6 до 40 г/л, тоді як середня селективність по мінеральним речовинам і лактозі склала 96,0 та 97,5 % відповідно. На основі отриманих результатів запропоновано двоетапну схему перероблення молочної сироватки.

Висновки. Отримані результати дослідження двоетапного перероблення молочної сироватки нанофільтрацією та зворотним осмосом можуть бути використані на молокопереробних підприємствах при розробленні технології комплексної переробки сироватки. Це дозволить використати всі компоненти сироватки, отримати очищену воду, придатну для повторного використання, та частково вирішити проблему забруднення навколишнього середовища молокопереробними підприємствами.

Ключові слова: *молочна сироватка, нанофільтрація, зворотний осмос, пермеат.*

Розподіл температур у системі комірок більший кристал цукру–розчин сахарози більшого кристалу–менший кристал цукру–розчин сахарози меншого кристалу–ульфелю залежно від часу уварювання цукрового ульфелю

Тарас Погорілий

Національний університет харчових технологій, Київ, Україна

Вступ. Найбільш енергоємним у виробництві цукру є процес отримання кристалічної сахарози. Для його керування в даній роботі реалізовано один із наступних етапів створення математичної моделі процесу кристалізації сахарози.

Матеріали і методи. Для одночасного розв'язання системи із 7 нестационарних задач теплопровідності по кожній області зі сталими та зі змінними теплофізичними коефіцієнтами застосовано чисельні методи (метод контрольного об'єму).

Результати і обговорення. Для двох випадків відносного часу уварювання цукрового ульфелю $\tau/\tau_{\text{ц}}$ ($\tau/\tau_{\text{ц}} = 0,15$ і $\tau/\tau_{\text{ц}} = 1,0$) знайдено розподіл температур в кожній області системи комірок на основі розв'язку системи нестационарних

диференціальних рівнянь у частинних похідних параболічного типу із змішаними граничними умовами (першого роду — для лівого краю першої області міжкристального розчину, та другого роду — для правого краю останньої області утфелю). Для кожного значення $\tau/\tau_{\text{ц}}$ знайдено два типи розв'язків: 1) розподіл температур у комірках системи залежно від часу контакту з нагрівальною трубкою; 2) розподіл температур у системі комірок на виході з нагрівальної трубки залежно від відстані від внутрішньої поверхні нагрівання трубки. В кожному з цих випадків було розглянуто два випадки різних нестационарних задач теплопровідності: I) зі сталими та II) зі змінними теплофізичними характеристиками по кожній області окремо. В усіх комірках температура, розрахована на основі змінних теплофізичних коефіцієнтів, менша по величині, ніж температура, розрахована на основі сталих теплофізичних коефіцієнтів. Результат розрахунків показав, що при $\tau/\tau_{\text{ц}} = 0,15$ максимальна різниця отриманих температур для нестационарної задачі теплопровідності зі змінними (порівняно зі сталими) теплофізичними коефіцієнтами лежить в межах 0,67 %. При $\tau/\tau_{\text{ц}} = 1,0$ максимальна різниця отриманих температур для нестационарної задачі теплопровідності зі змінними (порівняно зі сталими) теплофізичними коефіцієнтами лежить в межах 0,32 %. Це стосується області, що відповідає правій границі розчину сахарози меншого кристалу.

Висновки. Знайдено розподіл температур у системі комірок, що в одновимірному випадку представлено у вигляді семи областей: а) всередині нагрівальної трубки по кожній окремій області системи комірок — залежно від часу контакту $\tau_{\text{к}}(\tau/\tau_{\text{ц}})$; б) на виході з нагрівальної трубки в кожній центральній точці контрольного об'єму областей — в залежно від відстані x від внутрішньої поверхні гріючої трубки.

Ключові слова: температура, комірка, розчин, кристал, утфель.

Вплив стеарату кобальту на дестабілізацію поліетилену високого тиску

Анастасія Клещикова, Аркадій Петухов

Національний технічний університет України «Київський політехнічний інститут»,
Київ, Україна

Вступ. Метою є створення таймерної полімерної композиції на основі поліетилену високого тиску і стеарату кобальту, яка починає самодеструктувати через точно зазначений проміжок часу і може бути використана у виробництві міні-пакетів для пакування харчових продуктів у супермаркетах, що дозволить зменшити подальше забруднення навколишнього середовища.

Матеріали і методи. Для визначення технологічних параметрів переробки композиції проводилися термо-механічний і диференційно-термічний аналіз стеарату кобальту. Для оцінки дестабілізуючого впливу стеарату кобальту в таймерній суміші проводилося визначення усадки й умовної міцності та відносного видовження, визначення сухого залишку методом розчинення у ксилолі і водопоглинання. Інфрачервона спектроскопія застосована для оцінки дестабілізуючого впливу на молекулярному рівні.

Результати і обговорення. При визначенні властивостей стеарату кобальту термомеханічна крива підтвердила своїм плато перехід із псевдокристалічного в аморфний стан. Аналіз проводився за таких вихідних показників: температура початку вимірювань складає 16,8 °С, наважка матеріалу - 24,1 мг, чутливість приладу - 20мг, зростання температури складає 10°/хв, втрата маси після повного остигання печі складає 85,5 %, температура початку розкладання - 200 °С. Оптимальною

концентрацією стеарату кобальту є орієнтовно 3 %, при якому усадка плівкових зразків складала 46 %, значення повздовжньої умовної міцності падає після 3 місяців опромінення, що відповідає кліматичній зоні центральної України. Після розчинення в ксилолі відсоток втрати маси складає 99,74 %, що є порівняльною характеристикою глибини деградації ланцюгів. При визначенні водопоглинання максимальне значення опромінення, за якого можливе дослідження, складає 8 год, водопоглинання при цьому складає 21,4 %. Метод інфрачервоної спектроскопії дає найвищі показники утворення кетонних груп (в області спектра 1710-1725 см⁻¹), спиртових груп (1150 см⁻¹) і суттєве зростання кількості сорбційної води (3360 см⁻¹) при концентрації стеарату кобальту в орієнтовно 3 %, що на молекулярному рівні демонструє деградацію ланцюгів.

Висновок. Розроблена таймерна композиція на основі ПЕВТ і стеарату кобальту з максимальною ефективністю в орієнтовно 3 %, доведена її дієвість і працездатність.

Ключові слова: *самодеградуєючий, плівка, поліетилен, стеарат, кобальт, таймерний*

Економіка і управління

Ринок біологічно активних добавок і ліків, які відпускаються без рецептів у Чехії

Томаш Саділек

Економічний університет, Прага, Чехія

Вступ. Метою даного дослідження є оцінка поведінки споживачів БАД і ліків, які продаються без рецептів на ринку в Чеській Республіці, та визначення основних сегментів споживачів.

Матеріали і методи. Група клієнтів аптек у чеському місті була опитана з метою з'ясування того, як часто вони купують харчові добавки та ліки, які відпускаються без рецептів. Респондентами були люди у віці від 18 до 80, більшість з опитаних мали вищу освіту.

Результати і обговорення. Існує необхідність у проведенні освітніх заходів для споживачів щодо надійного використання лікарських трав і трав'яних дієтичних добавок. Це потрібно для того, щоб покращити свою поінформованість про межі безпечного використання трав'яних засобів захисту і визначення потенційних ризиків їх комбінації з наркотиками. Найбільш важливі висновки полягають у тому, що в Чеській Республіці 86 % респондентів купують харчові добавки і більшість споживачів (64 %) вважають, що добавки впливають на стан здоров'я. На підставі наших досліджень було визначено чотири сегменти, а саме: «піклування», «недовіра», «природна» і «довіра». Сегмент "піклування" найбільш численний (64 %), загалом споживачі купують знеболювальні ліки, витрачаючи при цьому найменше грошей (5,29 євро на місяць для ліків, які продаються без рецепта, і біологічно активних добавок). "Природні" клієнти складають 14 % населення Чехії. Ця група купує в основному харчові добавки та інші види ліків. "Довірливі покупці" купують ліки від грипу та застуди, а також для покращення травлення. Вони мають також другу за величиною кількість платежів за ліки, що продаються без рецептів, і біологічно активні добавки. "Недовірливі" клієнти не купують ліки, які продаються без рецептів, і біологічно активні добавки.

Висновок. Це дослідження дає змогу зробити комплексні висновки про ринок чеських дієтичних добавок і ліків, які продаються без рецептів.

Ключові слова: *маркетинг, ліки, БАД, Чехія.*

Інноваційні напрями розвитку підприємств спиртової промисловості України

Людмила Шевченко

Національний університет харчових технологій, Київ, Україна

Вступ. У дослідженні розглянуто проблему розвитку українських підприємств алкогольної промисловості, які в даний час фактично збиткові. Один із способів поліпшення стану підприємств — це створення механізму для підвищення рентабельності за рахунок впровадження інновацій.

Матеріали і методи. Для дослідження використано методи аналізу. Так, метод статистичного аналізу дає змогу проаналізувати пропорції залучення інвестицій в інновації в промисловість європейських країн, метод порівняння надає можливість проаналізувати результати для подальших досліджень. Для аналізу поняття інновації та необхідності впровадження інновацій у промисловість, підвищення прибутковості та конкурентоспроможності підприємств був використаний теоретичний метод.

Результати. Спиртова промисловість України потребує реанімації та виходу на нові ринки для продажу спирту. Для нашої країни необхідно інвестувати в інноваційне оновлення заводів і конвертувати частину заводів на виробництво іншого виду продукції.

Для успішного і конкурентоспроможного розвитку підприємств спиртової промисловості пропонується механізм підвищення рентабельності за рахунок впровадження інноваційної діяльності. Механізм складається з таких компонентів: стратегічне планування, яке передбачає попереднє планування і реалізацію процесів стратегічного планування; визначення методів збільшення прибутку для підприємств спиртової галузі; створення фонду інновацій на підприємстві. Для того, щоб зменшити ризик впровадження інновацій для підприємств спиртової промисловості, необхідно враховувати всі чинники. Останнім кроком є досягнення підтримки уряду в забезпеченні інноваційної діяльності для підприємств спиртової промисловості.

Висновок. Комплексний підхід до вивчення інноваційної діяльності дає змогу не тільки детально аналізувати матеріали, а й реалізувати технічні нововведення для підприємств спиртової промисловості нашої країни, що сприятиме зниженню собівартості реалізованої продукції, і, як наслідок, надасть можливість впроваджувати організаційні соціальні, економічні та юридичні інновації, поліпшити функцію прогнозування і планування.

Ключові слова: *інновація, спирт, промисловість, прибуток, технологія.*

Аннотации

Безопасность пищевых продуктов

Исследование токсикологического и фармакологического влияния новых купажей на организм биологических объектов

Наталия Пенкина¹, Лариса Татар¹, Анна Зайченко², Дмитрий Лыткин²
1 – Харьковский государственный университет питания и торговли, Харьков,
Украина

2 – Национальный фармацевтический университет, Харьков, Украина

Введение. Цель исследования – токсикологическое изучение купажа из растительного сырья, используемого для изготовления слабоалкогольных напитков.

Материалы и методы. Напиток, изготовленный методом натурального брожения, содержит 4,0 % алкоголя и смесь экстрактивных веществ различных растений с высокой антиоксидантной активностью. Изучали подострую токсичность купажа, его влияние на прооксидантно-антиоксидантное состояние печени белых мышей по сравнению с раствором спирта 4,0 % и пивом 4,0 %.

Результаты и обсуждение. После внутрижелудочного введения купажа в максимальной одноразовой для мышей дозе (36,1 г/кг в течение 14 дней) признаков интоксикации у животных не наблюдалось. Средняя масса животных (24,33 г) не выходила за пределы физиологической нормы и достоверно не отличалась ($p > 0,05$) от показателей средней массы животных группы интактного контроля.

Массовые коэффициенты печени (0,1 г /10,0 г) у животных интактного контроля (38,567) и тех, которым вводили купаж (39,467), значительно отличались от печени животных, которым вводили пиво (42,867) и раствор этилового спирта (45,633), – это начало развития компенсаторных проявлений, в частности, гипертрофии органа. Купаж уменьшает общее токсическое воздействие алкоголя на организм животных и не вызывает увеличения коэффициента массы их печени.

Биохимические исследования гомогената тканей печени животных, которым вводили купаж, показали, что содержание в печени диеновых конъюгатов (3,633 мкмоль/г), ТБК-реактантов (2,500 мкмоль/г), восстановленного глутатиона (2,420 мкмоль/г) и каталазы (0,163 мкмоль/мин·г) статистически не отличается от показателей у животных интактного контроля и находится в пределах физиологической нормы. В группе животных, которым вводили пиво, снижалось содержание восстановленного глутатиона (2,267 мкмоль/г) и уменьшалась активность каталазы (0,153 мкмоль/мин·г). В группе животных, которым вводили раствор спирта, достоверно изменение ($p < 0,05$): возросло содержание ТБК-реактантов (3,033 мкмоль/г), снижалось содержание восстановленного глутатиона (2,333 мкмоль/г) и подавлялась активность каталазы (0,157 мкмоль/мин·г).

Выводы. Напитки на основе исследуемого купажа, благодаря наличию алкопротекторного действия на печень, могут быть альтернативой современным пивным и слабоалкогольным напиткам, которые производятся с использованием спирта этилового.

Ключевые слова: напиток, антиоксидант, токсичность, спирт, купаж.

Пищевые технологии

Влияние типа злаков и метода сушения на функциональные свойства и пастообразность порошка оги

Эстер Ладуни¹, Адевуни Оейинка², Самсон Оейинка³, Чарльз Ауор¹
1 - Ибаданский университет, Нигерия

2 - Илоринский университет, г. Илорин, Нигерия

3 - Кварский государственный университет, г. Малете, Нигерия

Введение. Оги, также известный как жидкая каша, ферментированный пищевой продукт, который готовится из злаков. Цель исследования заключается в изучении влияния методов сушки и типа злаков на функциональные свойства порошка оги.

Материалы и методы. Кукуруза, просо и сорго (красный сорт) были получены на местном рынке в Ибадани, Нигерия. Оги готовился традиционными методами. Полученная суспензия сушится в камере и методом сушки в вспененном слое. Пастообразность и другие функциональные свойства сухого оги были оценены типовыми методами.

Результаты и обсуждение. Метод сушки не влияет на pH и способность к гелеобразованию оги, полученного из кукурузы, проса и сорго. Однако и метод сушки, и тип злака влияют на пастообразность и другие функциональные свойства сухого порошка оги. Образцы оги, высушенного во вспененном слое, демонстрируют значительно ($p < 0,05$) низший пик вязкости в сравнении с образцами, высушенными в камере. При росте концентрации пенообразующего агента от 5 до 15 % пик вязкости высушенного оги снижается. Однако оги, высушенный в камере, готовится быстрее (78-79 °C), чем образцы оги, высушенные в вспененном слое (80- 95 °C), что предопределено их температурами пастообразования. Образцы, полученные методом сушки во вспененном слое, в целом имеют высшие значения водопоглощения, чем образцы, высушенные в камере.

Выводы. Порошок оги, высушенный в вспененном слое, продемонстрировал лучшую способность к диспергированию и поглощению воды, пенообразованию и вязкости по сравнению с образцами, высушенными в камере. Выбор конкретного метода сушки для оги зависит от вида применения.

Ключевые слова: *оги, кукуруза, просо, сорго, пена, сушка, функциональность.*

Кинетика гидролиза-экстрагирования пектиновых веществ картофельного сырья

Елена Грабовская¹, Анна Пастух¹, Оксана Деменюк¹, Владимир Мирошник²,
Татьяна Галатенко¹, Алина Бабий¹, Алина Добридюк¹

1 - Национальный университет пищевых технологий, Киев, Украина

2 - Национальный университет биоресурсов и природопользования, Киев, Украина

Введение. Гидролиз-экстрагирование пектиновых веществ из растительного сырья является одним из самых сложных и важных процессов технологии получения пектина, поэтому исследование влияния технологических параметров на кинетику этого процесса является актуальным.

Материалы и методы. Предмет исследования — процесс гидролиза-экстрагирования пектина из картофельной мезги с использованием соляной

кислоты. Выход пектина определяли в процентах к массе сухих веществ. Кинетические константы рассчитывали по уравнению реакции первого порядка. Обработку экспериментальных данных, выбор уравнений, расчет и уточнение коэффициентов уравнений осуществляли с использованием метода наименьших квадратов.

Результаты. На основе проведенных экспериментальных исследований построены кинетические кривые процесса гидролиза-экстрагирования пектиновых веществ из картофельной мезги в зависимости от температуры и pH среды. Наибольшее влияние на скорость реакции гидролиза протопектина оказывает pH среды. При недостаточном содержании кислоты в качестве катализатора процесса даже при высоких температурах скорость реакции не значительна. Гидролиз протопектина сопровождается рядом нежелательных реакций, связанных с деструкцией пектина, что затрудняет определение константы скорости реакции. Путем планирования эксперимента и статистической обработки экспериментальных данных определены оптимальные параметры процесса гидролиза-экстрагирования картофельного пектина: температура — 75°C, pH гидролизной массы — 1,6; продолжительность гидролиза — 72 минуты.

Выводы. Применение результатов исследований при производстве пектина обеспечит максимальный выход пектина без нарушения его структуры.

Ключевые слова: *пектин, кинетика, гидролиз, экстрагирование, картофель, мезга.*

Качество высушенного сладкого перца после хранения

Михаель Одеволе¹, Зайнаб Айодимеджи¹, Кехинде Алаби²

1 - Илоринский университет, г. Илорин, Нигерия

2 - Кварский государственный университет, г. Малете, Нигерия

Введение. Свежий сладкий перец быстро портится, поэтому после предварительной обработки и высушивания можно увеличить срок его пригодности. При хранении продукты могут терять питательные вещества и поддаваться влиянию бактерий.

Материалы и методы. Исследовался предварительно обработанный сладкий перец. Показатели цвета определялись по Colour reference standard ISO 9002 с использованием AOCs тинтометра, Pt - Co (30 цветов), микробная нагрузка определена методом Коха с использованием термостата DHG 1923A. Содержание витаминов А и С определено по официальным методикам Ассоциации аналитической химии (Вашингтон).

Результаты и обсуждение. Из таблицы дисперсионного анализа видно, что влияние цвета как входного параметра и его взаимодействий было незначимым при $p \leq 5\%$, а все другие параметры и их взаимодействия существенно влияют на содержание витамина С. Падения в процентах содержания витаминов А и С до и после хранения при разных условиях процесса составляли 53,1% и 53,4% соответственно.

Микробная нагрузка составляет 6×10^6 КУО/мл и находится в пределах допустимого диапазона (10^7 КУО/мл и 10^8 КУО/мл) для готовых к употреблению овощей. Отмечено также лучшее сохранение цвета (темно-желтый) в предварительно обработанных образцах и высушенных необработанных образцах с глубоким коричневым цветом. Т-тест показал существенное отличие между содержанием витаминов А и С до и после хранения. Все вышеупомянутые замечания относительно

результатов возникают через разные факторы, такие как условия окружающей среды, тип носителя данных, характер свежих образцов в процессе роста и во время сбора урожая, погрузочно-разгрузочных работ до, при и после обработки и хранения, условий обработки проб перед хранением, длительности нахождения образцов в носители и т.д. Уравнения регрессии были разработаны для содержания витаминов А и С, бактериологической нагрузки и цвета. Только уравнение содержания витамина А не имеют достаточной прогнозирующей силы.

Выводы. В предварительно обработанных сушеных образцах сладкого перца микробиологические показатели и показатели питательных веществ были в норме после 20 месяцев хранения. Также сырье имело лучший цвет (темно-желтый). Разработанные уравнения регрессии могут быть использованы при прогнозировании содержания витамина С, микробной нагрузки и цвета.

Ключевые слова: сладкий перец, хранение, микробиология, витамин, качество.

Биотехнология, микробиология

Определение и характеристика бактериальных и грибковых изолятов в образцах сырого молока от разных пород коров

Муслиу Олушоло Сунмону, Майкл Майокун Одеволе,
Алиу Оламиде Ойедун, Хафсат Фунмилайо Банколен
Илоринский университет, г. Илорин, Нигерия

Введение. В исследовании проанализированы методы характеристики и определения бактериальных и грибковых изолятов в образцах сырого молока от разных пород коров.

Материалы и методы. Для исследования были собраны образцы молока от коров белый фулани и джерсийская, а также смешанной породы (белый фулани и джерсийская). Затем образцы были сгруппированы по четыре и пропастеризованы при температуре 71 °С в течение 15 секунд, при 66 °С в течение 15 минут и 61 °С в течение 30 минут с использованием пастеризаторов из алюминия, нержавеющей стали и оцинкованной стали.

Результаты и обсуждение. Образцы сырого молока были исследованы на предмет наличия бактериальных и грибковых изолятов: *Staphylococcus aureus*, *Bacillus subtilis*, *Euterobacter aerogenes*, *Escheria coli*, *Streptococcus lactis*, *Proteus vulgaris*, *Pseudomonas aeruginose*, *Serratia marcescens* и *Lactobacillus* - для бактериальных изолятов и *Aspergillus flavus*, *Aspergillus niger*, *Penicillium citrinum*, *Sacchanomyces Cerevisae*, *Paecilomyces Varioti*, *Penicillium Chrysogenum* - для грибковых изолятов. *Staphylococcus aureus* был обнаружен в 78,79 % всех образцов до и после пастеризации. Чаще всего в образцах сырого молока коров породы белый фулани, джерсийская и смешанной породы, а также в местном напитке из сброженного молока (ноно), встречаются бактерии *S. aureus*. Частота обнаружения других бактерий в образцах молока следующая: *B. subtilis* (6,06 %), *E. aerogenes* (42,42 %), *E. coli* (3,03 %), *S. lactis* (48,48 %), *P. vulgaris* (18,18 %), *P. aeruginosa* (30,30 %), *S. marcescens* (33,33 %), *L. fermentum* (30,30 %). Процентное распределение грибковых изолятов следующее: *A. flavus* (54 %), *A. niger* (18,18 %), *P. citrinum* (21,21 %), *S. cerevisiae* (57,58 %), *P. varioti* (15,15 %), *P. chrysogenum* (6,06 %). Наименьшее содержание бактерий было получено после пастеризации образцов при

71°C в течение 15 секунд в пастеризаторе из нержавеющей стали. Таким образом, наилучший результат достигается при быстрой пастеризации на высоких температурах. Для снижения количества грибковых изолятов следует использовать пастеризатор из нержавеющей стали и проводить обработку при 61°C в течение 30 минут.

Выводы. В процессе исследования в образцах сырого молока, полученных от коров различных пород, было выделено девять бактериальных и шесть грибковых изолятов.

Ключевые слова: молоко, бактерия, грибок, пастеризация.

Эффективность действия дезинфектантов относительно микроорганизмов – активных возбудителей кагатной гнили при хранении сахарной свеклы

Наталья Гусятинская¹, Светлана Тетерина¹, Татьяна Нечипор¹, Ирина Касян²

¹ – Национальный университет пищевых технологий, Киев, Украина

² – Смелянский техникум пищевых технологий НУИТ, Смела, Украина

Введение. Основной причиной потерь свекломассы и сахарозы, а также резкого снижения качества сырья и полупродуктов является развитие гнили корнеплодов сахарной свеклы при хранении в результате микробиологических процессов.

Материалы и методы. В качестве объектов исследования выбраны: чистые культуры слизеобразующих бактерий рода *Leuconostoc* и мицелиальных грибов, активных возбудителей кагатной гнили сахарной свеклы; корнеплоды селекции "Огух"; дезинфицирующие средства нового поколения.

Результаты и обсуждение. Определение активности возбудителей кагатной гнили проводили в условиях разной длительности и температуры хранения корнеплодов, предварительно зараженных определенным видом возбудителя кагатной гнили.

Таким образом, гриб *Botrytis cinerea Pers* проявил себя самым активным возбудителем кагатной гнили. Повышение температуры хранения до 15 ... 20 °C способствует развитию *Mucorales* и наиболее распространенных видов *Mucor mucedo* и *Rhizopus nigricans*, которые за короткий срок способны привести свеклу в непригодное к переработке состояние.

В пробах сахарной свеклы, зараженных *Geotrichum candidum* и *Torula beticola*, в условиях хранения при температуре 0 ... 5 °C в течение 45 суток наблюдалось наличие внешнего мицелия, но развитие кагатной гнили практически отсутствовало.

Средства «Санитарин», «Жавель-Клейд», «Биодез» и «Гембар» оказали высокую эффективность с точки зрения ингибирования развития мицелиальных грибов. Средство «Нобак фермент» по сравнению со средством «Нобак» оказало высокий антимикробный эффект относительно более широкого спектра микроорганизмов.

Средство «Бетастаб» проявило высокую эффективность относительно слизеобразующих бактерий, в частности рода *Leuconostoc*, хотя при таком же расходе не проявило эффективность по угнетению микромицетов. Дезинфицирующее средство «Каморан» является активным по отношению к широкому спектру микроорганизмов, в том числе микромицетам и слизеобразующим бактериям.

Выводы. Большинство исследуемых средств имеют стабильное фунгицидное и фунгистатическое действие по отношению к широкому спектру микромицетов и эффективно ингибируют развитие слизеобразующих бактерий.

Ключевые слова: дезинфектант, микромицет, слизеобразование, бактерия, сахарная свекла.

Процессы и оборудование пищевых производств

Двухэтапная переработка молочной сыворотки нанофильтрацией и обратным осмосом

Иванна Киричук¹, Валерий Мирончук¹, Юрий Змиевский¹, Сергей Голячук²
1 – Национальный университет пищевых технологий, Киев, Украина
2 – Луцкий национальный технический университет, Луцк, Украина

Введение. Переработка молочной сыворотки, которая является побочным продуктом сыродельного производства, представляет большой интерес для молочной промышленности, поскольку она содержит большое количество ценных и питательных веществ. Однако актуальным остается вопрос разработки комплексной переработки сыворотки, в том числе мембранными методами, и путей использования продуктов ее разделения.

Материалы и методы. Для исследований использовали молочную сыворотку и пермеат, полученный после ее концентрирования нанофильтрацией. Эксперименты проводились на установке непроточного типа с использованием нанофильтрационной ОПМН-П и обратноосмотической НаноРО мембран.

Результаты. Учитывая высокое содержание лактозы в сыворотке и результаты, полученные при разделении растворов лактозы на мембране ОПМН-П, обоснована целесообразность концентрирования молочной сыворотки нанофильтрацией до содержания сухих веществ в ней в пределах 20-22 %.

Во время концентрирования сыворотки наблюдали две стадии снижения удельной производительности: быстрое снижение в начале процесса и дальнейшее постепенное возрастание. Первая стадия обусловлена загрязнением мембраны, а вторая — концентрационным поляризацией, образованием слоя осадка и ростом его толщины.

Согласно анализу полученных зависимостей удельной производительности и селективности обратноосмотической мембраны НаноРО от давления установлено, что рациональное значение давления для проведения процесса концентрирования пермеата после нанофильтрации молочной сыворотки составляет 3,0 МПа. При таком давлении удельная производительность снизилась вдвое с ростом концентрации раствора от 6 до 40 г/л, тогда как средняя селективность по минеральным веществам и лактозе составила 96,0 и 97,5 % соответственно. На основе полученных результатов предложена двухэтапная схема переработки молочной сыворотки.

Выводы. Полученные результаты исследования двухэтапной переработки молочной сыворотки нанофильтрацией и обратным осмосом могут быть использованы на молокоперерабатывающих предприятиях при разработке технологии комплексной переработки сыворотки. Это позволит использовать все компоненты молочной сыворотки, получить очищенную воду, пригодную для повторного использования, и частично решить проблему загрязнения окружающей среды молокоперерабатывающими предприятиями.

Ключевые слова: *молочная сыворотка, нанофильтрация, обратный осмос, пермеат.*

Распределение температур в системе ячеек большой кристалл сахара–раствор сахарозы большого кристалла–меньший кристалл сахара–раствор сахарозы меньшего кристалла–утфель в зависимости от времени уваривания сахарного утфеля

Тарас Погорелый

Национальный университет пищевых технологий, Киев, Украина

Введение. Наиболее энергоемким при производстве сахара является процесс получения кристаллической сахарозы. Для его управления в данной работе реализован один из следующих этапов создания математической модели процесса кристаллизации сахарозы.

Материалы и методы. Для одновременного решения системы из 7 нестационарных задач теплопроводности по каждой области с постоянными или с переменными теплофизическими коэффициентами был применен численный метод (метода контрольного объема).

Результаты и обсуждение. Для двух случаев относительного времени уваривания сахарного утфеля ($\tau/\tau_{ц}=0,15$ и $\tau/\tau_{ц}=1,0$) найдено распределение температуры в каждой области рассматриваемой системы ячеек на основании решения системы нестационарных дифференциальных уравнений в частных производных параболического типа со смешанными граничными условиями (первого рода — для левой границы первой области межкристалльного раствора, и второго рода — для правой границы последней области утфеля).

Для каждого значения $\tau/\tau_{ц}$ найдено два типа решения: 1) распределение температуры в ячейках системы в зависимости от времени контакта с греющей трубкой; 2) распределение температуры в системе ячеек на выходе из нагревательной трубки в зависимости от расстояния от внутренней поверхности нагревательной трубки. В каждом из этих случаев также рассмотрено два случая различных нестационарных задач теплопроводности: I) с постоянными и II) с переменными теплофизическими характеристиками по каждой области отдельно. Во всех ячейках значение температуры, которые были найдены на основании переменных теплофизических коэффициентов меньше по величине, чем значения температуры, полученные на основании постоянных теплофизических коэффициентов. Результат расчетов показал, что при $\tau/\tau_{ц} = 0,15$ максимальная разница полученных температур для нестационарной задачи теплопроводности с переменными (по сравнению с постоянными) теплофизическими коэффициентами находится в пределах 0,67 %. При $\tau/\tau_{ц} = 1,0$ максимальная разница полученных температур для нестационарной задачи теплопроводности с переменными (по сравнению с постоянными) теплофизическими коэффициентами находится в пределах 0,32 %. Это касается области, которая соответствует правой границе раствора сахарозы меньшего кристалла.

Вывод. Найдено распределение температур в системе ячеек: а) в середине нагревательной трубки по каждой отдельной области системы ячеек — в зависимости от времени контакта $\tau_k(\tau/\tau_{ц})$; б) на выходе из нагревательной трубки в каждой центральной точке контрольного объема областей — в зависимости от расстояния x от внутренней поверхности греющей трубки.

Ключевые слова: температура, ячейка, раствор, кристалл, утфель.

Влияние стеарата кобальта на дестабилизацию полиэтилена высокого давления

Анастасия Клещёва, Аркадий Петухов

Национальный технический университет Украины «Киевский политехнический институт», Киев, Украина

Введение. Целью исследования является создание таймерной полимерной композиции на основе полиэтилена высокого давления и стеарата кобальта, которая начинает самодеструктурировать через точно определённый отрезок времени и может быть использована в производстве мини-пакетов для упаковки пищевых продуктов в супермаркетах, что позволит уменьшить дальнейшее загрязнение окружающей среды.

Материалы и методы. Для определения технологических параметров переработки композиции проводились термо-механический и дифференциально-термический анализ стеарата кобальта. Для оценки дестабилизирующего влияния стеарата кобальта в таймерной смеси проводилось определение усадки, условной прочности и относительного удлинения, сухого остатка методом растворения в ксилоле и водопоглощения. Инфракрасная спектроскопия применялась для оценки дестабилизирующего влияния на молекулярном уровне.

Результаты и обсуждения. При определении свойств стеарата кобальта, термомеханическая кривая подтвердила своим плато переход из псевдокристаллического в аморфное состояние. Анализ проводился при следующих исходных показателях: температура начала измерений $16,8^{\circ}\text{C}$, навеска материала - 24,1 мг, чувствительность прибора - 20мг, повышение температуры - $10^{\circ}/\text{мин}$, потеря массы после полного остывания печи 85,5 %, температура начала разложения - 200°C . Оптимальной концентрацией является область 3 %, в которой усадка плёночных образцов составила 46 %, значение продольной условной прочности падает после 3 месяцев облучения, что соответствует климатической зоне центральной Украины. После растворения в ксилоле процент потери массы составляет 99,74 %, что является сравнительной характеристикой глубины деградации цепей. При определении водопоглощения, максимальное значение облучения, позволяющее проведение исследования, составляло 8 ч, водопоглощение — 21,4 %. Метод инфракрасной спектроскопии даёт наивысшие показатели образования кетонных групп (в области спектра $1710\text{-}1725\text{ см}^{-1}$), спиртовых групп (1150 см^{-1}) и существенное возрастание количества сорбционной воды (3360 см^{-1}) при концентрации стеарата кобальта в рамках 3 %, что на молекулярном уровне демонстрирует деградацию цепей.

Выводы. Разработана таймерная композиция на основе полиэтилена высокого давления и стеарата кобальта с максимальной эффективностью в области 3 %, доказана её действенность и работоспособность.

Ключевые слова: *самодеградирующий, плёнка, полиэтилен, стеарат, кобальт, таймерный, композиция.*

Экономика и управление

Инновационные направления развития предприятий спиртовой отрасли Украины

Людмила Шевченко

Национальный университет пищевых технологий, Киев, Украина

Введение. В исследовании рассмотрена проблема развивающихся украинских предприятий спиртовой отрасли, которые в настоящее время фактически убыточны. Один из способов улучшения состояния предприятий алкогольной — создание механизма для повышения рентабельности за счет внедрения инноваций.

Материалы и методы. Для исследования использованы методы анализа. Метод статистического анализа позволяет проанализировать пропорции инноваций в промышленность европейских стран, метод сравнения предоставляет возможность проанализировать результаты для дальнейших исследований. Для анализа понятия инновации и необходимости внедрения инноваций в промышленность, повышения прибыльности и конкурентоспособности предприятий использован теоретический метод.

Результаты. Спиртовая промышленность Украины нуждается в реанимации и выходе на новые рынки для продажи спирта. Для нашей страны необходимо инвестировать в инновационное обновление заводов и конвертировать часть заводов на производство другого вида продукции.

Для успешного и конкурентоспособного развития предприятий спиртовой промышленности предлагается механизм повышения рентабельности за счет внедрения инновационной деятельности. Механизм состоит из таких компонентов: стратегическое планирование, которое предполагает предварительное планирование и реализацию процессов стратегического планирования; определение методов увеличения прибыли для предприятий спиртовой отрасли; создание фонда инноваций на предприятии. Для того, чтобы уменьшить риск внедрения инноваций для предприятий спиртовой промышленности, необходимо учитывать все факторы. Последним шагом является достижение поддержки правительства в обеспечении инновационной деятельности для предприятий спиртовой промышленности.

Вывод. Комплексный подход к изучению инновационной деятельности позволяет не только детально анализировать материалы, но и реализовать технические новшества для предприятий спиртовой промышленности нашей страны, что позволит снизить себестоимость реализованной продукции и, как следствие, предоставляет возможность внедрить организационные, социальные, юридические и экономические инновации, улучшить функцию прогнозирования и планирования.

Ключевые слова: *инновация, промышленность, спирт, прибыль, технология.*

Рынок биологически активных добавок и лекарств, которые отпускаются без рецептов в Чехии

Томаш Садилек

Экономический университет, Прага, Чехия

Введение. Целью данного исследования является оценка поведения потребителей БАД и лекарств, которые продаются без рецептов на рынке в Чешской Республике, и определение основных сегментов потребителей.

Материалы и методы. Группа клиентов аптек в чешском городе была опрошена с целью выяснения того, как часто они покупают пищевые добавки и лекарства, которые отпускаются без рецептов. Респондентами были люди в возрасте от 18 до 80, большинство из опрошенных имели высшее образование.

Результаты и обсуждение. Существует необходимость в проведении образовательных мероприятий для потребителей относительно надежного использования лекарственных трав и травяных диетических добавок. Это необходимо для того, чтобы улучшить свою осведомленность о пределах безопасного использования травяных средств защиты и определения потенциальных рисков их комбинации с наркотиками. Наиболее важные выводы заключаются в том, что в Чешской Республике 86 % респондентов покупают пищевые добавки и большинство потребителей (64 %) считают, что добавки влияют на здоровье. На основании наших исследований были определены четыре сегмента, а именно: "забота", "недоверие", "природный" и "доверие". Сегмент "забота" является наиболее многочисленным (64 %). Потребители покупают в целом обезболивающие, но тратят наименьшее количество денег (5,29 евро в месяц на лекарства, которые продаются без рецепта, и биологически активные добавки). "Естественные" клиенты составляют 14 % населения Чехии. Эта группа покупает в основном пищевые добавки и другие виды лекарств. "Доверчивые покупатели" покупают лекарства от гриппа и простуды, а также для улучшения пищеварения. Они имеют второе по величине количество платежей за лекарства, которые продаются без рецептов, и биологически активные добавки. "Недоверчивые" клиенты не покупают лекарства, которые отпускаются без рецептов, и биологически активные добавки.

Вывод. Это исследование позволяет сделать комплексные выводы о рынке чешских диетических добавок и лекарств, которые продаются без рецепта.

Ключевые слова: маркетинг, лекарства, БАД, Чехия.

Instructions for authors



Dear colleagues!

The Editorial Board of scientific periodical
«**Ukrainian Food Journal**»
invites you to publication of your scientific research.

Requirements for article:

Language – English, Ukrainian, Russian

Size of the article – 8-15 pages in Microsoft Word 2003 and earlier versions with filename extension *.doc (!)

All article elements should be in Times New Roman, font size 14, 1 line intervals, margins on both sides 2 cm.

The structure of the article:

1. The title of the article
2. Authors (full name and surname)
3. Institution, where the work performed.
4. Abstract (2/3 of page). The structure of the abstract should correspond to the structure of the article (Introduction, Materials and methods, Results and discussion, Conclusion).
5. Key words.

Points from 1 to 5 should be in English, Ukrainian and Russian.

6. The main body of the article should contain the following obligatory parts:

- Introduction
- Materials and methods
- Results and discussing
- Conclusion
- References

If you need you can add another parts and divide them into subparts.

7. The information about the author (Name, surname, scientific degree, place of work, email and contact phone number).

All figures should be made in graphic editor, the font size 14.

The background of the graphs and charts should be only in white color. The color of the figure elements (lines, grid, text) - in black color.

Figures and EXCEL format files with graphs additionally should submit in separate files.

Photos are not appropriate to use.

Website of Ukrainian Food Journal: www.ufj.ho.ua

Extended articles should be sent by email to: ufj_nuft@meta.ua

Шановні колеги!

Редакційна колегія наукового періодичного видання «**Ukrainian Food Journal**» запрошує Вас до публікації результатів наукових досліджень.

Вимоги до оформлення статей

Мови статей – англійська, українська, російська
Рекомендований обсяг статті – **8-15 сторінок** формату А4.
Стаття виконується в текстовому редакторі Microsoft Word 2003, в форматі *.doc.
Для всіх елементів статті шрифт – **Times New Roman**, кегль – **14**, інтервал – 1.
Всі поля сторінки – по 2 см.

Структура статті:

1. УДК.
2. **Назва статті.**
3. Автори статті (ім'я та прізвище повністю, приклад: Денис Озеряно).
4. *Установа, в якій виконана робота.*
5. Анотація. Обов'язкова структура анотації:
 - Вступ (2-3 рядки).
 - Матеріали та методи (до 5 рядків)
 - Результати та обговорення (пів сторінки).
 - Висновки (2-3 рядки).
6. Ключові слова (3-5 слів, але не словосполучень).

Пункти 2-6 виконати англійською, українською та російською мовами.

7. Основний текст статті. Має включати такі обов'язкові розділи:
 - Вступ
 - Матеріали та методи
 - Результати та обговорення
 - Висновки
 - Література.

За необхідності можна додавати інші розділи та розбивати їх на підрозділи.

8. Авторська довідка (Прізвище, ім'я та по батькові, вчений ступінь та звання, місце роботи, електронна адреса або телефон).
9. Контактні дані автора, до якого за необхідності буде звертатись редакція журналу.

Рисунки виконуються якісно. Скановані рисунки не приймаються. Розмір тексту на рисунках повинен бути **співрозмірним (!)** тексту статті. **Фотографії бажано не використовувати.**

Фон графіків, діаграм – лише білий. Колір елементів рисунку (лінії, сітка, текст) – чорний (не сірий).

Рисунки та графіки EXCEL з графіками додатково подаються в окремих файлах.

Скорочені назви фізичних величин в тексті та на графіках позначаються латинськими літерами відповідно до системи СІ.

В списку літератури повинні переважати статті та монографії іноземних авторів, які опубліковані після 2000 року.

Правила оформлення списку літератури

В Ukrainian Food Journal взято за основу загальноприйняте в світі спрощене оформлення списку літератури згідно стандарту Garvard. Всі елементи посилання розділяються **лише комами**.

1. Посилання на статтю:

Автори А.А. (рік видання), Назва статті, Назва журналу (курсивом), Том (номер), сторінки.

Ініціали пишуться після прізвища.

Всі елементи посилання розділяються комами.

1. Приклад:

Popovici C., Gitin L., Alexe P. (2013), Characterization of walnut (*Juglans regia* L.) green husk extract obtained by supercritical carbon dioxide fluid extraction, *Journal of Food and Packaging Science, Technique and Technologies*, 2(2), pp. 104-108.

2. Посилання на книгу:

Автори (рік), Назва книги (курсивом), Видавництво, Місто.

Ініціали пишуться після прізвища.

Всі елементи посилання розділяються комами.

Приклад:

2. Wen-Ching Yang (2003), *Handbook of fluidization and fluid-particle systems*, Marcel Dekker, New York.

Посилання на електронний ресурс:

Виконується аналогічно посиланню на книгу або статтю. Після оформлення даних про публікацію пишуться слова **available at:** та вказується електронна адреса.

Приклади:

1. (2013), *Svitovi naukovometrychni bazy*, available at:

http://www1.nas.gov.ua/publications/q_a/Pages/scopus.aspx

2. Cheung T. (2011), *World's 50 most delicious drinks [Text]*, available at:

<http://travel.cnn.com/explorations/drink/worlds-50-most-delicious-drinks-883542>

Список літератури оформлюється лише латиницею. Елементи списку українською та російською мовою потрібно транслітерувати. Для транслітерації з українською мови використовується паспортний стандарт, а з російської - стандарт МВД (в цих стандартах використовуються символи лише англійського алфавіту, без хвостиків, апострофів та ін).

Зручні сайти для транслітерації:

З української мови - <http://translit.kh.ua/#lat/passport>

З російської мови - <http://ru.translit.net/?account=mvd>

Додаткова інформація та приклад оформлення статті – на сайті

<http://ufj.ho.ua>

Стаття надсилається за електронною адресою: **ufj_nuft@meta.ua**

Ukrainian Food Journal публікує оригінальні наукові статті, короткі повідомлення, оглядові статті, новини та огляди літератури.

Тематика публікацій в Ukrainian Food Journal:

Харчова інженерія	Процеси та обладнання
Харчова хімія	Нанотехнології
Мікробіологія	Економіка та управління
Фізичні властивості харчових продуктів	Автоматизація процесів
Якість та безпека харчових продуктів	Упаковка для харчових продуктів
	Здоров'я

Періодичність виходу журналу 4 номери на рік.

Результати досліджень, представлені в журналі, повинні бути новими, мати чіткий зв'язок з харчовою наукою і представляти інтерес для міжнародного наукового співтовариства.

Ukrainian Food Journal індексується наукометричними базами:

Index Copernicus (2012)
 EBSCO (2013)
 Google Scholar (2013)
 UlrichsWeb (2013)
 Global Impact Factor (2014)
 Online Library of University of Southern Denmark (2014)
 CABI full text (2014)
 Directory of Research Journals Indexing (DRJI) (2014)
 Universal Impact Factor (2014)
 Directory of Open Access scholarly Resources (ROAD) (2014)
 European Reference Index for the Humanities and the Social Sciences (ERIH PLUS) (2014)
 Directory of Open Access Journals (DOAJ) (2015)
 InfoBase Index (2015)

Рецензія рукопису статті. Матеріали, представлені для публікування в «Ukrainian Food Journal», проходять «Подвійне сліпе рецензування» двома вченими, призначеними редакційною колегією: один є членом редколегії і один незалежний учений.

Авторське право. Автори статей гарантують, що робота не є порушенням будь-яких авторських прав, та відшкодовують видавцю порушення даної гарантії. Опубліковані матеріали є правовою власністю видавця «Ukrainian Food Journal», якщо не узгоджено інше.

Політика академічної етики. Редакція «Ukrainian Food Journal» користується правилами академічної етики, викладених в роботі Miguel Roig (2003, 2006) "Avoiding plagiarism, self-plagiarism, and other questionable writing practices. A guide to ethical writing". Редакція пропонує авторам статей і рецензентам прямо слідувати цьому керівництву, щоб уникнути помилок у науковій літературі.

Інструкції для авторів та інша корисна інформація розміщені на сайті

<http://ufj.ho.ua>

Редакційна колегія

Головний редактор:

Валерій Манк, д-р. техн. наук, проф., *Національний університет харчових технологій, Україна*

Члени редакційної колегії:

Александр Мамцев, д-р. техн. наук, проф., *філія Московського державного університету технології та управління в м. Мелеуз, Республіка Башкортостан, Росія*
Анатолій Сайганов, д-р. екон. наук, проф., *Інститут системних досліджень в АПК НАН Беларусі*

Валерій Мирончук, д-р. техн. наук, проф., *Національний університет харчових технологій, Україна*

Віктор Стабніков, канд. техн. наук, доц., *Національний університет харчових технологій, Україна*

Віргінія Юреніс, д-р., проф., *Вільнюський університет, Литва*

Віталій Таран, д-р. техн. наук, проф., *Національний університет харчових технологій, Україна*

Володимир Ковбаса, д-р. техн. наук, проф., *Національний університет харчових технологій, Україна*

Володимир Іванов, д-р., проф., *Державний університет Іови, США*

Владімір Груданов, д-р. техн. наук, проф., *Беларуський державний аграрний технічний університет*

Галина Сімахіна, д-р. техн. наук, проф., *Національний університет харчових технологій, Україна*

Ірина Федулова, д-р. екон. наук, проф., *Національний університет харчових технологій, Україна*

Йорданка Стефанова, д-р, *Пловдивський університет "Паїсій Хілендарскі", Болгарія*

Крістіна Попович, д-р., доц., *Технічний університет Молдови*

Микола Сичевський, д-р. екон. наук, проф., *Інститут продовольчих ресурсів НААН України*

Марк Шамця, канд. техн. наук, доц., *Санкт-Петербурзький державний технологічний інститут, Росія*

Олександр Шевченко, д-р. техн. наук, проф., *Національний університет харчових технологій, Україна*

Олена Грабовська, д-р. техн. наук, проф., *Національний університет харчових технологій, Україна*

Олена Драган, д-р. екон. наук, проф., *Національний університет харчових технологій, Україна*

Ольга Петухова, д-р. екон. наук, доц., *Національний університет харчових технологій, Україна*

Ольга Рибак, канд. техн. наук, доц., *Тернопільський національний технічний університет імені Івана Пулюя, Україна*

Паскаль Дюпю, д-р, *Університет Клод Бернард Ліон 1, Франція*

Стефан Стефанов, д-р., проф., *Університет харчових технологій, Болгарія*
Тетяна Мостенська, д-р. екон. наук, проф., *Національний університет харчових технологій, Україна*
Тетяна Пирог, д-р. біол. наук, проф., *Національний університет харчових технологій, Україна*
Томаш Бернат, д-р., проф., *Щецинський університет, Польща*
Юлія Дзязько, д-р. хім. наук, с.н.с., *Інститут загальної та неорганічної хімії імені В. І. Вернадського НАН України*
Юрій Білан, д-р., *Щецинський університет, Польща*
Олексій Губеня (відповідальний секретар), канд. техн. наук, доц., *Національний університет харчових технологій, Україна.*

Contents of Volume 4 Year 2015

Food Technologies

Issue 1

Olena Hrabovska, Hanna Pastukh, Veronika Moiseeva, Volodymyr Miroshnyk
Potato pectin: extract methods, physical and chemical properties and structural features 7

Olena Kovalenko, Dmytro Vietrov
Requirements to technological water quality for tea drinks preparation 14

Olha Masliichuk, Svitlana Maykova
Health-improving effect of meat products with soy protein-fatty concentrator and carrageenan 24

Olga Snizhko, Neonila Lomova, Narizhnyy Sergiy, Mingaleeva Zamira
Enhancing food safety of pollen by means of irradiation 32

Natalia Kondratjuk, Tetiana Stepanova, Pavlo Pyvovarov, Yevgen Pyvovarov
Modeling of low calorie pectin-based product composition 40

Olena Onopriychuk, Olena Grek, Alla Tymchuk
Optimization of the composition of the mixture by simplex method 49

Issue 2

Gjore Nakov, Dragan Damjanovski, Valentina Pavlova, Daniela Nedelkoska, Ljupka Necinova, Nastia Ivanova, Stanka Damyanova, Oleksii Gubenia
Impact of the kind of wine storage on chemical and physical characteristics 271

Ali Aberoumand, Saeed Ziaei-Nejad
Effects of processing on the proximate composition and energetic values in two fish species from Iran southern waters 281

Maninder Pal Jaggi, Rekha Sharma, Sabiha Vali
Effect of packaging and storage conditions on retention of ascorbic acid in fenugreek leaves (*Trigonella Foenum-Graecum*) 288

Зміст тому 4 2015 рік

Харчові технології

N 1

Олена Грабовська, Ганна Пастух, Вероніка Моїсеєва, Володимир Мірошник
Картопляний пектин: способи вилучення, фізико-хімічні властивості та особливості структури

Олена Коваленко, Дмитро Ветров
Вимоги до якості технологічної води для приготування напоїв з чайної сировини

Ольга Маслійчук, Світлана Майкова
Оздоровчий ефект м'ясних виробів із соєвим білково-жировим збагачувачем і карагінаном

Ольга Сніжко, Неоніла Ломова, Сергій Наріжний, Заміра Мінгалєєва
Вплив опромінення на продовольчу безпеку і якість бджолиного обніжжя

Наталія Кондратюк, Тетяна Степанова, Павло Пивоваров, Євген Пивоваров
Моделювання складу низькокалорійного продукту на основі пектину

Олена Онопрійчук, Олена Грек, Алла Тимчук
Оптимізація складу суміші симплекс-методом

N 2

Гьоре Наків, Драган Дямяновські, Валентина Павлова, Даніела Неделкоска, Люпка Несінова, Настя Іванова, Станка Дамянова, Олексій Губеня
Вплив способу зберігання на фізико-хімічні характеристики вина Вранац

Ali Aberoumand, Saeed Ziaei-Nejad
Вплив обробки двох видів риб з південних вод Ірану на їх склад і енергетичну цінність

Maninder Pal Jaggi, Rekha Sharma, Sabiha Vali
Вплив упаковки і умов зберігання на збереження аскорбінової кислоти в листі гуньби

<i>Natalia Murlykina, Olena Upatova, Marina Yancheva, Olena Ukleina, Maryna Murlykina</i> Application of infrared spectroscopy for quantitative analysis of new food emulsifiers	299	<i>Наталя Мурликiна, Марина Янчева, Олена Упатова, Олена Уклеiна, Марина Мурликiна</i> Застосування iнфрачервоної спектроскопiї у кiлькiсному аналізі нових харчових емульгаторiв	
<i>Svitlana Bazhay-Zhezherun, Mariia Antoniuk, Julia Smulska</i> Biologically activated wheat grain as a functional component of glazed bars	310	<i>Наталя Мурликiна, Марина Янчева, Олена Упатова, Олена Уклеiна, Марина Мурликiна</i> Бiологiчно активоване зерно пшеницi як функцiональний компонент батончика глазурованого	
<i>Sergii Gubskiyi, Sergii Nikitin, Victoria Evlash, Oleksandra Nemirich</i> Iodine content determination in dried talli of laminaria by galvanostatic coulometry	320	<i>Сергiй Губськи, Сергiй Нiкiтiн, Вiкторiя Євлаш, Олександр Немiрич</i> Визначення вiстуту йоду в сушених сланях ламiнарiї методом гальваностатичної кулонометрiї	
Issue 3		№ 3	
<i>Farah Shamim, Abdual Rahim Khan, Muhamaad Azhar Ali</i> Classification of maturity indices of mango fruit for safe harvesting and storage	402	<i>Фара Шамим, Абдул Рахим Кан, Мухамад Ажар Али</i> Класифiкацiя показникiв стиглостi плодiв манго для забезпечення безпечного збору i зберiгання урожаю	
<i>Tetiana Lisovska, Olga Rybak, Mykola Kuhtyn, Nina Chorna</i> Investigation of water binding in sponge cake with extruded corn meal	413	<i>Тетяна Лiсовська, Ольга Рибак, Микола Кухтин, Нiна Чорна</i> Дослiдження форм зв'язку вологи в бiсквітному напiвфабрикатi з використанням екструдованого кукурудзяного борошна	
<i>Adesoji Matthew Olaniyan, Musliu Olushola Sunmonu, Michael Mayokun Odewole, Oluwaseun Ige</i> Process conditions governing the drying rate and quality of tomato powder obtained from foam-mat dried tomato paste	423	<i>Адесойи Метью Оланиян, Муслиу Олушола Сунмону, Майкл Майокун Одеволе, Олусанью Олувасеун Iгe</i> Технологiчні умови, що регулюють швидкiсть сушіння i якiсть томатного порошку, отриманого з томатної пасти методом пiнного сушіння	
<i>Vasyl Pasichniy, Natalia Yushchenko, Ivan Mykoliv, Ulyana Kuzmyk</i> Structure stabilization of fermented-milk pastes	431	<i>Василь Пасiчний, Наталiя Ющенко, Иван Миколiв, Ульяна Кузьмик</i> Стабiлiзацiя структури кисломолочних паст	
<i>Rositsa Denkova, Bogdan Goranov, Georgi Dobrev, Zapryana Denkova, Georgi Kostov, Petya Boyanova, Desislava Teneva, Simon Fortier</i> Rheological properties of probiotic yoghurts with phytosterol ester	440	<i>Росiца Денкова, Богдан Горанов, Георгi Добрев, Запряна Денкова, Георгi Костов, Петя Боянова, Десислава Тенева, Саймон Фортьер</i> Властивостi реологiї пробiотичних йогуртiв iз змiстом складного ефiру фiтостеролу	
<i>Galina Simakhina, Nataliia Naumenko, Kateryna Yarosh</i> New non-traditional sources of food protein	453	<i>Галина Сiмахiна, Наталiя Науменко, Катерина Ярош</i> Новi нетрадицiйнi джерела харчового бiлку	

- Hülya Turan, Demet Kocatepe, Can Okan Altan, Gizem Gökner*
Effect of different thawing methods on the quality of fbonito (Sarda sarda, Bloch 1793) 460
- Florentin Acho, Lessoy Zoué, Niamkey Adom, Sébastien Niamké*
Impact of freezing processing on nutritive and antioxidant properties of leafy vegetables consumed in Southern Côte d'Ivoire 467
- Issue 4**
- Esther Laduni, Adewumi Toyin Oyeyinka, Samson Adeoye Oyeyinka, Charles Ogugua Aworh*
Effect of drying method and cereal type on functional and pasting properties of ogi powder 587
- Olena Hrabovska, Hanna Pastukh, Oksana Demenyuk, Volodymyr Miroshnyk, Tetyana Halatenko, Alina Babii, Alina Dobrydnuk*
Kinetics of hydrolysis-extraction of pectin substances from the potato raw materials 596
- Michael Mayokun Odewole, Zainab Oyinlola Ayodimeji, Kehinde Peter Alabi*
Post-storage qualities of pre-treated dried red bell pepper 605
- Biotechnology, microbiology**
- Issue 1**
- Rositsa Denkova, Bogdan Goranov, Zapryana Denkova, Vesela Shopkska, Georgi Kostov*
Determination of the kinetic parameters of batch fermentation of *Lactobacillus plantarum* X2 with probiotic potential isolated from spontaneously fermented sourdough 59
- Bogdan Goranov, Rositsa Denkova, Desislava Teneva, Zapryana Denkova, Petya Popova*
Molecular-genetic identification of *Lactobacillus* strains, isolated from homemade yoghurt 67
- Issue 4**
- Musliu Olushola Sunmonu, Michael Mayokun Odewole, Aliu Olamide Oyedun, Hafsat Funmilayo Bankolen*
Identification and characterization of bacterial and fungal isolates in raw milk samples from different breeds 617
- Хьоля Туран, Демет Коцатепе, Цан Окан Алтан, Гізем Гьокнар*
Вплив різних способів розморожування на якість скумбрії (Sarda sarda, Bloch, 1793)
- Флорентин Ахо, Лессой Зоуэ, Адом Ніамке, Себастьян Ніамке*
Вплив заморожування на поживні і антиоксидантні властивості листових овочів, що споживаються в південній частині Кот-д'Івуара
- N 4**
- Естер Ладуні, Адеуні Оейінка, Самсон Оейінка, Чарльз Ауор*
Вплив типу злаків та методу сушіння та функціональні властивості та пастоподібність порошку ogi
- Олена Грабовська, Ганна Пастух, Оксана Деменюк, Володимир Мірошник, Тетяна Галатенко, Аліна Бабій, Аліна Добридюк*
Кінетика гідролізу-екстрагування пектинових речовин картопляної сировини
- Міхаель Одеволе, Зайнаб Айодімеджі, Кехінде Алабі*
Якість висушеного солодкого перцю після зберігання
- Біотехнологія, мікробіологія**
- N 1**
- Росіца Денкова, Богдан Горанов, Запрянна Денкова, Весела Шопска, Георгі Костов*
Визначення кінетичних параметрів періодичного культивування *Lactobacillus plantarum* X2 з пробіотичним потенціалом, виділеного із спонтанно ферментованої тістової закваски
- Богдан Горанов, Росіца Денкова, Десислава Танєва, Запрянна Денкова*
Молекулярно-генетична ідентифікація штамів *Lactobacillus*, ізольованих із домашнього кислого молока
- N 4**
- Мусліу Олушола Сунмону, Майкл Майокун Одеволе, Аліу Оламідє Оєдун, Хафсат Фунмілайо Банколен*
Визначення і характеристика бактерійних і грибоквих ізолятів у зразках сирого молока від різних порід корів

Natalia Husyatynska, Svitlana Teterina, Tetiana Nechipor, Irina Kasian
 Disinfectants efficiency on microorganisms - active gray rot causative agents within the process of sugar beet storage 626

Наталія Гусятинська, Світлана Тетеріна, Тетяна Нечипор, Ірина Касян
 Ефективність дії дезінфектантів щодо мікроорганізмів – активних збудників кагатної гнилі під час зберігання цукрових буряків

Processes and equipment of food productions

Issue 1

Sviatoslav Lementar, Vitaliy Ponomarenko, Дмитро Люлька, Анастасія Дубівко
 Modeling of the air supply system in spray dry 77

Eduard Biletskyi, Olena Petrenko, Dmytro Semeniuk
 Methos for defining hydraulic losses during power-law fluids flow 88

Paul Ebiensa, Vladimir Grudanov, Aleksei Ermakov, Vladimir Pozdniakov
 Improving the process of roasting malt with intensive stirring machine 95

Andriy Svitlyk, Oleksandr Prokhorov
 Research of process of absorpotion of carbon dioxide with water in capillary-porous elements 109

Igor Litovchenko, Stefan Stefanov, Vilhelm Hadzhiyski
 Investigation work proofer by computer simulation 119

Liudmyla Kornienko, Yurii Zmievskii, Valeriy Myronchuk
 Investigation of ultrafiltration of grain stillage 127

Issue 2

Grygorii Deinychenko, Zahar Mazniyak, Dmytro Kramarenko, Vasyi Guzenko
 Determination of ultrafiltration membranes shrinkage factor 328

Oleksandr Liulka, Dmytro Liulka, Valerii Myronchuk, Yevhen Bulakh
 Comparative analysis of beet cosettes extraction of different profiles on the industrial extractors 335

Процеси та обладнання харчових виробництв

№ 1

Святослав Лементар, Віталій Пономаренко, Дмитро Люлька, Анастасія Дубівко
 Моделювання системи подачі повітря в розпилювальних сушильних установках

Едуард Білецький, Олена Петренко, Дмитро Семенюк
 Методика визначення гідравлічних втрат при течії степеневих рідин

Пол Ебіенса, Владімір Груданов, Алексей Ермаков, Владімір Поздняков
 Дослідження процесу обжарювання солоду в обжарювальному апараті з інтенсивним перемішуванням

Андрій Світлик, Олександр Прохоров
 Дослідження процесу абсорбції діоксиду вуглецю водою в капілярно-пористих елементах

Ігор Литовченко, Стефан Стефанов, Вільгельм Хаджійський
 Дослідження роботи шафи вистоювання шляхом комп'ютерного моделювання

Людмила Корнієнко, Юрій Змієвський, Валерій Мирончук
 Дослідження процесу ультрафільтрації післяспиртової зернової барди

№ 2

Григорій Дейниченко, Захар Мазняк, Дмитро Крамаренко, Василь Гузенко
 Визначення коефіцієнта ущільнення структури ультрафільтраційних мембран Олександр Люлька, Дмитро Люлька, Валерій Мирончук, Євген Булах

Порівняльний аналіз знецукрення бурякової стружки різних профілів на промислових екстракторах

Issue 3

Yaroslav Korniyenko, Sergii Gulienko, Mykyta Lialka
Mathematical simulation of fouled membrane modules regeneration

481

Yaroslav Zasiadko, Oleksiy Pylypenko, Roman Gryshchenko, Andriy Forsiuk
Experimental and theoretical study of ice formation on vertical cooled pipes

494

Issue 4

Ivanna Kyrychuk, Valeriy Myronchuk, Yurii Zmiievskii, Serhii Holiachuk
Two-stage whey treatment by nanofiltration and reverse osmosis

638

Taras Pogoriliy
Temperatures distribution in the «larger sugar crystal–larger crystal sucrose solution–less crystal sugar sucrose solution–smaller sugar crystal–massecuite» cells system depending on the boiling sugar massecuite time

648

Anastasiia Klieshchova, Arcadiy Pietuhov
Influence of cobalt stearate on destabilization of high-pressure polyethylene

662

Automatization of technological processes

Issue 1

Volodymyr Shesterenko, Oleg Mashchenko, Oleksandra Shesterenko
Problem of increasing the power factor in industrial enterprises

134

Issue 3

Tetyana Dzhurenko, Olena Myakshylo, Galina Cherednichenko
Analysis of Text Mining methods in Web search

508

Life Safety

Issue 1

Olga Evtushenko, Alina Siryc, Petro Porotko, Tatsiana Krukouskaya
Analysis of indicators of workplace occupational injuries at the food industry enterprises of Ukraine

157

N 3

Ярослав Корнієнко, Сергій Гулієнко, Микита Лялька
Математичне моделювання регенерації забруднених мембранних модулів

Ярослав Засядько, Олексій Пилипенко, Роман Грищенко, Андрій Форсюк
Експериментальне і теоретичне дослідження намерозування льоду на вертикальних охолоджуваних трубах

N 4

Іванна Киричук, Валерій Мирончук, Юрій Змієвський, Сергій Голячук
Двоетапна переробка молочної сироватки нанофільтрацією та зворотним осмосом

Тарас Погорілий
Розподіл температур в системі комірок: «більший кристал цукру–розчин сахарози більшого кристалу–менший кристал цукру–розчин сахарози меншого кристалу–утфель» в залежності від часу уварювання цукрового утфелю

Анастасія Клещова, Аркадій Петухов
Вплив стеарату кобальту на дестабілізацію поліетилену високого тиску

Автоматизація технологічних процесів

N 1

Володимир Шестеренко, Олег Мащенко, Олександра Шестеренко
Підвищення коефіцієнта потужності на промислових підприємствах

N 3

Тетяна Джуренко, Олена М'якишло, Галина Чередніченко
Аналіз методів TEXT MINING у роботі з пошуковою системою

Безпека життєдіяльності

N 1

Ольга Євтушенко, Аліна Сірик, Петро Поротко, Тетяна Крюковська
Аналіз показників виробничого травматизму на робочих місцях підприємств харчової промисловості України

Economics and Management

Issue 3

Svitlana Rozumey, Olga Krainiuchenko, Tetiana Belova
Strategic decisions on distribution channels 520

Mirosława Tereszczuk, Robert Mroczek
Assessment of development of the food industry in Poland against European Union countries 530

Issue 4

Tomáš Sadílek
Buying dietary supplements and over the counter drugs in the Czech Republic 674

Liudmyla Shevchenko
Innovative trends for the alcohol enterprises of Ukraine 684

Marketing

Issue 1

Nwankwo Ignatius Uche
Social dimensions of genetics and their implications for uptake of genetically modified foods and new food technologies in society 145

Food safety

Issue 2

Yuriy I. Posudin, Kamaranga S. Peiris, Stanley J. Kays
Non-destructive detection of food adulteration to guarantee human health and safety 207

Igor Bordun, Vadym Ptashnyk, Mariana Sardyga, Roksolana Chapovska, Andrzej Baryga
Perspectives of wedge-shaped dehydration method for evaluation of physical and chemical properties of multicomponent aqueous solution 261

Issue 3

Yuriy Posudin, Vasyly Kostenko
Infrared spectroscopy of milk 377

Musliu Olushola Sunmonu, Obafemi Obajemih, Michael Mayokun Odewole, Aliu Olamide Oyedun, Hafsat Funmilayo Bankole
Effects of different pasteurizers on the microbial quality of raw milk samples 390

Економіка і управління

N 3

Світлана Розумей, Ольга Крайнюченко, Тетяна Белова
Стратегічні рішення стосовно каналів розподілу

Мирослава Терещук, Роберт Мроцек
Харчова промисловість Польщі у загальній структурі продовольчого сектору Європейського Союзу

N 4

Томаш Саділек
Ринок біологічно активних добавок та ліків, які відпускаються без рецептів в Чехії

Людмила Шевченко
Інноваційні напрями розвитку підприємств спиртової промисловості України

Маркетинг

N 1

Nwankwo Ignatius Uche
Соціальні аспекти генетики та їх наслідки для поширення в суспільстві генетично модифікованих харчових продуктів і нових харчових технологій

Безпека харчових продуктів

N 2

Юрій Посудін, Камаранга С. Пейріс, Стенлі Д. Кейз
Неруйнівне виявлення фальсифікації харчових продуктів як засіб забезпечення здоров'я і безпеки людства

Ігор Бордун, Вадим Пташник, Мар'яна Сардига, Роксолана Чаповська, Анджей Барига
Перспективи використання методу клиновидної дегідратації для оцінки фізико-хімічних властивостей багатокomпонентних водних розчинів

N 3

Юрій Посудін, Василь Костенко
Інфрачервона спектроскопія молока

Мусліу Олушола Сунмону, Обафемі Обайеміхі, Майкл Майокун Одеволе, Аліу Оламідє Ойедун, Хафсат Фунмільайо Банколе
Вплив виду пастеризатора на мікробіологічні показники зразків сирого молока

Issue 4

Natalia Penkina, Larisa Tatar, Ganna Zaychenko, Dmytro Lytkin

Research of the toxicological and pharmacological effects of new blends on the body of biological objects

N 4

Наталія Пенкіна, Лариса Татар, Ганна Зайченко, Дмитро Литкін

577 Дослідження токсикологічного та фармакологічного впливу нових купажів на організм біологічних об'єктів

Наукове видання

Ukrainian Food Journal

**Volume 4, Issue 4
2015**

**Том 4, № 4
2015**

Підп. до друку 24.12.2015 р. Формат 70x100/16.
Обл.-вид. арк. 12.24. Ум. друк. арк. 12.46.
Гарнітура Times New Roman. Друк офсетний.
Наклад 100 прим. Вид. № 26н/15.

НУХТ. 01601 Київ-33, вул. Володимирська, 68

Свідоцтво про державну реєстрацію
друкованого засобу масової інформації
КВ 18964-7754Р
видане 26 березня 2012 року.